



# ALAGAPPA UNIVERSITY

[Accredited with 'A+' Grade by NAAC (CGPA:3.64) in the Third Cycle  
and Graded as Category-I University by MHRD-UGC]

(A State University Established by the Government of Tamil Nadu)

KARAIKUDI – 630 003



## Directorate of Distance Education

### M.A. (Journalism and Mass Communication)

I - Semester

309 11

# INTRODUCTION TO JOURNALISM & MASS COMMUNICATIONS

<b>Reviewer</b>	
Dr. N. Johnson	Assistant Professor, Department of Lifelong Learning, Alagappa University, Karaikudi

#### **Authors**

**Dr Hemanta Kumar Joshi**, Associate Professor, Hindi Journalism, Indian Institute of Mass Communication, Delhi  
**Manjari Joshi**, News Reader, Delhi Doordarshan and Freelance Journalist

Units: (1, 2, 3.2.2, 4.2, 5.2, 5.4, 6.2, 6.3, 9, 10.3, 11.2.3-11.2.4)

**Ruchi Jaggi**, Assistant Professor, Symbiosis Institute of Media and Communication, Pune

Units: (3.2, 11.2-11.2.1, 14.2)

**Prof K M Srivastava**, Indian Institute of Mass Communication, Jawaharlal Nehru University, New Delhi

Units: (6.3.1, 7)

**Vikas® Publishing House**, Units (3.0-3.1, 3.2.1, 3.2.3-3.2.5, 3.3-3.7, 4.0-4.1, 4.3-4.8, 5.0-5.1, 5.3, 5.4.1, 5.5-5.9, 6.0-6.1, 6.4-6.8, 8, 10.0-10.1, 10.2, 10.4-10.4.1, 10.5-10.9, 11.0-11.1, 11.2.2, 11.2.5-11.2.6, 11.3-11.7, 12, 13.0-13.1, 13.2-13.3, 13.4-13.8, 14.0-14.1, 14.2.1-14.2.2, 14.3-14.7)

"The copyright shall be vested with Alagappa University"

All rights reserved. No part of this publication which is material protected by this copyright notice may be reproduced or transmitted or utilized or stored in any form or by any means now known or hereinafter invented, electronic, digital or mechanical, including photocopying, scanning, recording or by any information storage or retrieval system, without prior written permission from the Alagappa University, Karaikudi, Tamil Nadu.

Information contained in this book has been published by VIKAS® Publishing House Pvt. Ltd. and has been obtained by its Authors from sources believed to be reliable and are correct to the best of their knowledge. However, the Alagappa University, Publisher and its Authors shall in no event be liable for any errors, omissions or damages arising out of use of this information and specifically disclaim any implied warranties or merchantability or fitness for any particular use.



VIKAS® is the registered trademark of Vikas® Publishing House Pvt. Ltd.

VIKAS® PUBLISHING HOUSE PVT. LTD.

E-28, Sector-8, Noida - 201301 (UP)

Phone: 0120-4078900 • Fax: 0120-4078999

Regd. Office: 7361, Ravindra Mansion, Ram Nagar, New Delhi 110 055

• Website: www.vikaspublishing.com • Email: helpline@vikaspublishing.com

**Work Order No. AU/DDE/DE1-238/Preparation and Printing of Course Materials/2018 Dated 30.08.2018 Copies - 500**

---

# SYLLABI-BOOK MAPPING TABLE

## Introduction to Journalism & Mass Communications

---

Syllabi	Mapping in Book
<b>BLOCK I: COMMUNICATION AND VARIOUS MODELS OF COMMUNICATION</b>	
<b>UNIT -1</b> Communication: Definitions - Communication and Society - Types of Communication	<b>Unit 1:</b> Introduction to Communication (Pages 1-15);
<b>UNIT -2</b> Basic models of Communication - Linear Model - Non-Linear Model	<b>Unit 2:</b> Basic Models of Communication (Pages 16-30);
<b>UNIT -3</b> Communication, Culture and Media Literacy - Internet and Society - Impact on Politics - Education - Business and Culture.	<b>Unit 3:</b> Communication and Culture (Pages 31-50);
<b>UNIT -4</b> The Human Communication Process - A Review of Some Basic Models and the Ingredients.	<b>Unit 4:</b> Communication Process (Pages 51-58)
<b>BLOCK II: JOURNALISM AND ITS ETHICS</b>	
<b>UNIT -5</b> The Concept of Journalism - The Functions of Press - Press Freedom - Responsibility and the Theories of Press	<b>Unit 5:</b> Concept and Functions of Journalism (Pages 59-78);
<b>UNIT -6</b> Current Trends in Journalism - Press Codes and Ethics of Journalism - A Code of Ethics for the Indian Press.	<b>Unit 6:</b> Codes and Ethics of Journalism (Pages 79-105);
<b>UNIT -7</b> Press Commissions and Committees - The First and Second Press Commission Reports	<b>Unit 7:</b> Overview of Press Commissions and Committees (Pages 106-112);
<b>UNIT -8</b> Reports of Chanda Committee - Varghese Committee - Joshi Committee - Karanth Working Group etc.	<b>Unit 8:</b> Reports of Media Committees (Pages 113-118)
<b>BLOCK III: MEDIA AND ITS FUNCTIONS AND TYPES</b>	
<b>UNIT -9</b> Media for Mass Communication - Print Media - Electronic Media - Radio - Television and New Media	<b>Unit 9:</b> Mass Communication Media (Pages 119-145);
<b>UNIT -10</b> Prasar Baharati Bill - FM and Community Radio - DTH - Cable Revolution.	<b>Unit 10:</b> Public Broadcasting and the Cable Revolution (Pages 146-159);
<b>UNIT -11</b> Mass Media Institutions in India - Government Media Units – Akashvani, Doordarshan, PIB, DAVP etc. - Press Registrar of India, Press council of India	<b>Unit 11:</b> Mass Media Institutions in India (Pages 160-176)
<b>BLOCK 4: INDIAN NEWS AGENCIES AND ITS STATUS IN INDIA</b>	
<b>UNIT -12</b> Indian News agencies - Professional organizations as INS, AINEC, IFWJ, PRST, AAAI, ILNA etc., - Media educational institutions.	<b>Unit 12:</b> Media Agencies, Organizations and Institutions (Pages 177-188);
<b>UNIT -13</b> Introduction to Mass Media - Meaning of Mass Media - The Concept of Mass Media - The Influence of Technology on the Means of Communication	<b>Unit 13:</b> Introduction to Mass Media (Pages 189-195);
<b>UNIT -14</b> A Discussion of the Characteristics of Individual Mass Medium - Mass Media in India - Present Status of Mass Media - Advantages of Mass Media - Limitations of Mass Media	<b>Unit 14:</b> A Discussion on the Characteristics of Individual Mass Medium (Pages 196-204)

---

---

# CONTENTS

---

## INTRODUCTION

## BLOCK I: COMMUNICATION AND VARIOUS MODELS OF COMMUNICATION

### UNIT 1 INTRODUCTION TO COMMUNICATION 1-15

- 1.0 Introduction
- 1.1 Objectives
- 1.2 Communication: Definitions
- 1.3 Communication and Society
- 1.4 Types of Communication
- 1.5 Answers to Check Your Progress Questions
- 1.6 Summary
- 1.7 Key Words
- 1.8 Self Assessment Questions and Exercises
- 1.9 Further Readings

### UNIT 2 BASIC MODELS OF COMMUNICATION 16-30

- 2.0 Introduction
- 2.1 Objectives
- 2.2 Linear Model
- 2.3 Non-linear Model
- 2.4 Answers to Check Your Progress Questions
- 2.5 Summary
- 2.6 Key Words
- 2.7 Self Assessment Questions and Exercises
- 2.8 Further Readings

### UNIT 3 COMMUNICATION AND CULTURE 31-50

- 3.0 Introduction
- 3.1 Objectives
- 3.2 Communication, Culture and Media Literacy
  - 3.2.1 Media Literacy
  - 3.2.2 Internet and Society
  - 3.2.3 Impact of Media on Politics
  - 3.2.4 Media Education
  - 3.2.5 Business and Culture
- 3.3 Answers to Check Your Progress Questions
- 3.4 Summary
- 3.5 Key Words
- 3.6 Self Assessment Questions and Exercises
- 3.7 Further Readings

**UNIT 4 COMMUNICATION PROCESS 51-58**

- 4.0 Introduction
- 4.1 Objectives
- 4.2 The Human Communication Process
- 4.3 A Review of Some Basic Models and the Ingredients
- 4.4 Answers to Check Your Progress Questions
- 4.5 Summary
- 4.6 Key Words
- 4.7 Self Assessment Questions and Exercises
- 4.8 Further Readings

**BLOCK II: JOURNALISM AND ITS ETHICS**

**UNIT 5 CONCEPT AND FUNCTIONS OF JOURNALISM 59-78**

- 5.0 Introduction
- 5.1 Objectives
- 5.2 The Concept of Journalism
  - 5.2.1 The Functions of the Press
- 5.3 Press Freedom
- 5.4 Responsibility of the Press
  - 5.4.1 Theories of Press
- 5.5 Answers to Check Your Progress Questions
- 5.6 Summary
- 5.7 Key Words
- 5.8 Self Assessment Questions and Exercises
- 5.9 Further Readings

**UNIT 6 CODES AND ETHICS OF JOURNALISM 79-105**

- 6.0 Introduction
- 6.1 Objectives
- 6.2 Current Trends in Journalism
- 6.3 Press Codes and Ethics of Journalism
  - 6.3.1 A Code of Ethics for the Indian Press
- 6.4 Answers to Check Your Progress Questions
- 6.5 Summary
- 6.6 Key Words
- 6.7 Self Assessment Questions and Exercises
- 6.8 Further Readings

**UNIT 7 OVERVIEW OF PRESS COMMISSIONS AND COMMITTEES 106-112**

- 7.0 Introduction
- 7.1 Objectives
- 7.2 Press Commissions and Committees
  - 7.2.1 First Press Commission
  - 7.2.2 Second Press Commission
- 7.3 Answers to Check Your Progress Questions
- 7.4 Summary
- 7.5 Key Words
- 7.6 Self Assessment Questions and Exercises
- 7.7 Further Readings

**UNIT 8    REPORTS OF MEDIA COMMITTEES** **113-118**

- 8.0 Introduction
- 8.1 Objectives
- 8.2 Chanda Committee
  - 8.2.1 Joshi Committee
- 8.3 Verghese Committee
- 8.4 Karanth Working Group
- 8.5 Answers to Check Your Progress Questions
- 8.6 Summary
- 8.7 Key Words
- 8.8 Self Assessment Questions and Exercises
- 8.9 Further Readings

**BLOCK III: MEDIA AND ITS FUNCTIONS AND TYPES**

**UNIT 9    MASS COMMUNICATION MEDIA** **119-145**

- 9.0 Introduction
- 9.1 Objectives
- 9.2 Media for Mass Communication
- 9.3 Print Media
- 9.4 Electronic Media
- 9.5 Radio
- 9.6 Television
  - 9.6.1 Cinema
- 9.7 New Media
- 9.8 Answers to Check Your Progress Questions
- 9.9 Summary
- 9.10 Key Words
- 9.11 Self Assessment Questions and Exercises
- 9.12 Further Readings

**UNIT 10    PUBLIC BROADCASTING AND THE CABLE REVOLUTION** **146-159**

- 10.0 Introduction
- 10.1 Objectives
- 10.2 Prasar Bharati Bill
- 10.3 FM and Community Radio
- 10.4 DTH and Cable Revolution
  - 10.4.1 Current Status
- 10.5 Answers to Check Your Progress Questions
- 10.6 Summary
- 10.7 Key Words
- 10.8 Self Assessment Questions and Exercises
- 10.9 Further Readings

**UNIT 11    MASS MEDIA INSTITUTIONS IN INDIA** **160-176**

- 11.0 Introduction
- 11.1 Objectives
- 11.2 Government Media Units
  - 11.2.1 Doordarshan

- 11.2.2 Akashvani
- 11.2.3 PIB
- 11.2.4 DAVP
- 11.2.5 Press Registrar of India
- 11.2.6 Press Council of India
- 11.3 Answers to Check Your Progress Questions
- 11.4 Summary
- 11.5 Key Words
- 11.6 Self Assessment Questions and Exercises
- 11.7 Further Readings

## **BLOCK IV: INDIAN NEWS AGENCIES AND ITS STATUS IN INDIA**

### **UNIT 12 MEDIA AGENCIES, ORGANIZATIONS AND INSTITUTIONS 177-188**

- 12.0 Introduction
- 12.1 Objectives
- 12.2 Indian News Agencies
- 12.3 Professional Media Organizations
- 12.4 Media Educational Institutions
- 12.5 Answers to Check Your Progress Questions
- 12.6 Summary
- 12.7 Key Words
- 12.8 Self Assessment Questions and Exercises
- 12.9 Further Readings

### **UNIT 13 INTRODUCTION TO MASS MEDIA 189-195**

- 13.0 Introduction
- 13.1 Objectives
- 13.2 Meaning and Concept of Mass Media
- 13.3 The Influence of Technology on the Means of Communication
- 13.4 Answers to Check Your Progress Questions
- 13.5 Summary
- 13.6 Key Words
- 13.7 Self Assessment Questions and Exercises
- 13.8 Further Readings

### **UNIT 14 A DISCUSSION ON THE CHARACTERISTICS OF INDIVIDUAL MASS MEDIUM 196-204**

- 14.0 Introduction
- 14.1 Objectives
- 14.2 Mass Media in India
  - 14.2.1 Present Status of Mass Media
  - 14.2.2 Advantages and Limitations of Mass Media
- 14.3 Answers to Check Your Progress Questions
- 14.4 Summary
- 14.5 Key Words
- 14.6 Self Assessment Questions and Exercises
- 14.7 Further Readings

---

## INTRODUCTION

---

### NOTES

In the world of 21st century, defined by information technology and electronics, the power of media is for all of us to see. More and more people are getting attracted to various forms of media. In fact, print, electronics and cyber journalism are largely defining the styles, choices, attitudes, hopes and aspirations of the masses. Under such a scenario, the studies in journalism and mass communication are acquiring more and more importance.

This book, *Introduction to Journalism and Mass Communication*, offers a comprehensive view of the basics of mass communication and journalism. Starting from the definition, types and functions of communication, the book goes about explaining the origin and history of press in India and the world, models of communication and the latest trends in mass media.

This book is divided into fourteen units that follow the self-instruction mode with each unit beginning with an Introduction to the unit, followed by an outline of the Objectives. The detailed content is then presented in a simple but structured manner interspersed with Check Your Progress Questions to test the student's understanding of the topic. A Summary along with a list of Key Words and a set of Self Assessment Questions and Exercises is also provided at the end of each unit for recapitulation.



---

**BLOCK - I**  
**COMMUNICATION AND VARIOUS MODELS**  
**OF COMMUNICATION**

---

*Introduction to  
Communication*

**NOTES**

---

**UNIT 1 INTRODUCTION TO**  
**COMMUNICATION**

---

**Structure**

- 1.0 Introduction
- 1.1 Objectives
- 1.2 Communication: Definitions
- 1.3 Communication and Society
- 1.4 Types of Communication
- 1.5 Answers to Check Your Progress Questions
- 1.6 Summary
- 1.7 Key Words
- 1.8 Self Assessment Questions and Exercises
- 1.9 Further Readings

---

**1.0 INTRODUCTION**

---

Communication is an all pervasive phenomenon. All living beings from animals to the humans are involved in one or other type of communication. In this unit, we will make an attempt to explore this wonderful gift of nature. We will begin with the general meaning of this word and then go deeper into various definitions of communication as a subject of study. In order to understand the real meaning of this term, various aspects of communication need to be understood. We will find out what are the factors and functions of communication and how many types of communication are found in the human society. We will also discuss about the dynamics of the relationship which 'communication' shares with individuals, society at large, the political sphere, development and culture. Finally, we will talk about the recent trends like globalization and convergence of media that have comprehensively facilitated the transformation of human communication from interpersonal to mass communication.

After reading the unit you would be able to analyse communication in a wider sense and understand its reach and impact on the human beings and the society.

**NOTES**

---

## 1.1 OBJECTIVES

---

After going through this unit, you will be able to:

- Define communication
- Discuss the relationship between communication and society
- Describe the different types of communication

---

## 1.2 COMMUNICATION: DEFINITIONS

---

The process of communication has played a vital role in the evolution of life on earth. Communication made its presence felt right from the time when the first pulsating amoeba came to life. Communication should not be seen as something which involves language and other signs; rather it should be viewed as the transmission of any signal from a source to the destination for the purpose of affecting the state of the destination in some way. In this sense, all physiological processes may also be considered as a type of ‘communication’.

Communication is both an art and a science. It may be an inborn quality or a talent as it is when we say ‘the gift of the gab’. On the other hand, it is a discipline amenable to systematic study and mastery. It has an element of creativity, as well as an element of precision. It calls for mastering of skills as well as techniques.

Communication is also an interdisciplinary subject. It encompasses literature, sociology, psychology and statistics. With electronic communication gaining popularity, an understanding of technology and the way the gadgets work would also be helpful. All the same, while knowledge of various disciplines comes in handy in improving communication skills, there have been effective communicators even without much formal education.

The world of communication is a complex, expansive and an evolving world. It assumes a very dynamic character as the methods, channels, instruments and approaches relating to the process of communication respond to new situations and challenges. The spectrum of communication assumes a pervasive quality in the contemporary world and defies description as it constantly reaches out and assumes new meanings. Communication is to be understood in terms of what it does. More than a discipline, it is a way of life. Communication is both an art and a science. It may be an inborn quality or a talent as it is when we say ‘the gift of the gab’. On the other hand, it is a discipline amenable to systematic study and mastery. It has an element of creativity, as well as an element of precision. It calls for mastering of skills as well as techniques.

Communication is also an interdisciplinary subject. It encompasses literature, sociology, psychology and statistics. For example, when we talk to our friends, we talk about a variety of subjects of interest. With electronic communication

gaining popularity, an understanding of technology and the way the gadgets work would also be helpful. All the same, while knowledge of various disciplines comes in handy in improving communication skills, there have been effective communicators even without much formal education.

We have many other types of communications where the signals or the object transferred from source to destination may not be a message prepared in signs and symbols. The terms like telecommunication or transportation have been differentiated from the communication described here in this unit.

Harold Benjamin, a learned Professor of education has described communication as 'a necessary tool of learning and mass communication is prerequisite to mass education'. He further says: 'A public-spirited press is therefore a chief instrument whereby contemporary society orders and changes its ways in the direction of clearly envisioned goals of increased human welfare.' For example, we have news channels that provide news and information twenty-four seven. It is through these channels that a person sitting in the eastern or any other part of the world is able to know what is happening in the western or any other part of the world.

For an easier understanding of the term, communication may be defined in the following manner:

Communication is the process of sharing or exchange of ideas, information, knowledge, attitude and feeling among two persons or a group of people through certain signs and symbols or passing of information from source to destination.

Communication has become as essential for the survival as the food or air. People want to learn about each other, they want to know what is happening around them, they want to sit together to discuss and plan their destinies, and they resolve problems and crisis by communicating to each other. The governments and the businesses around the world feel the need to communicate with the citizens or consumers on a day-to-day basis. This significance has made communication a very important area of studies.

The word 'communication' is derived from the Latin word 'communicatio' or 'communicare' that means communicate, discuss, impart or share. It was used prominently in French in late 14th century and later in English. The meaning has not changed but with the growth of knowledge about societies there have been various specific meanings attached to this word.

Different dictionaries and encyclopaedia define communication in their own way. Random House dictionary, for example, gives the following meanings of the word communication:

1. The act or process of communicating; fact of being communicated.
2. The imparting or interchange of thoughts, opinions, or information by speech, writing, or signs.

## NOTES

## NOTES

3. Something imparted, interchanged, or transmitted.
4. A document or message imparting news, views, information, etc.
5. Passage or opportunity or means of passage between places
6. Communications, a means of sending messages, orders, etc., including telephone, telegraph, radio, and television. *b.* routes and transportation for moving troops and supplies from a base to an area of operations.
7. Biology. *a.* activity by one organism that changes or has the potential to change the behaviour of other organisms. *b.* transfer of information from one cell or molecule to another, as by chemical or electrical signals.

Business dictionary defines it as: 'Two-way process of reaching mutual understanding, in which participants not only exchange (encode-decode) information but also create and share meaning.'

However, after the emergence of communication studies, the need to define communication differently and distinctively was felt. Hence, one needs to go through long descriptions and explanations before reaching anywhere near a satisfying definition of communication. Dance and Larson (1973) did a survey of the literature on communication and found that there were 126 definitions, and since then even more definitions have been formulated. One of the reasons for the proliferation of definitions is that there is no single approach to the study of communication. In fact, this and other units in the book are meant to provide a larger and broader perspective of communication and journalism to the students.

Generally, communication is seen as a linear one-way or two-way sequence of events from Person X to Person Y or vice versa. This type of technical view defines communication simply as 'sending and receiving messages' or 'the transmission of messages'. Nevertheless, the efforts to solve the engineering or technical problems do not throw sufficient light upon the complexity of communication or the human aspects of communication.

Another more sophisticated view of communication is that, apart from the transmission of messages, it comprises their meanings and interpretation. According to this view, communication is a human phenomenon and the fundamental aspect of our existence. Our highly evolved communication abilities distinguish us from other life forms. Meaning-centred academicians focus on issues like:

- what inspires and motivates individuals to communicate
- how do they provide meaning to each other's messages,
- what occurs between/among them during communication, and
- how do they use language to produce and exchange meaningful messages.

The stress is on the interaction between/among the participants in the process of communication. From this viewpoint, communication may be defined as 'a dynamic process of exchanging meaningful messages'.

### **Check Your Progress**

1. Where is the word communication derived from?
2. What is the technical view of communication?

### **NOTES**

---

## **1.3 COMMUNICATION AND SOCIETY**

---

Societies cannot be imagined without communication nor is there any communication without society or individuals. Communication being one of the important needs of the society has developed from speech to Internet to facilitate the process of human development. The society over the years has greatly benefitted from the development of communication to consolidate the gains of knowledge and social orders. The Internet has influenced societies as rigid in its structure as the Indian society. A knowledge-driven society such as the USA has a different pattern of society that a country such as, let us say, India has. While communication in the USA is based on the principles of equality and individuality, communication in India is based upon a lot of factors such as gender, caste, social status, age, etc. The Indian society has still been unable to shake off the biases prevalent in so many areas. Also, over the years, a disturbing trend in the Indian children's attitude towards their parents has been noted. This is in opposition to the western people who are gradually allured by the wisdom of the East. While Indians have been seen as more reserved and introverted in their social dealings, the Americans are considered to be more outspoken and extrovert. So, it can be said that a lack of communication leads to a lack of expression. Perhaps, that is why the Indian society is still a prejudiced society.

### **Individual and Social Need**

Communication for people is as normal and necessary activity as breathing or eating food. Every one of us needs to talk to people immediately after we get up and people around us also want to tell us something or the other throughout the day. Human beings need to communicate to fulfil their basic needs as well as to make them aware about their surroundings and society in which they live. Communication also helps people to learn to lead life in the society and negotiate as and when required. In short, communication is a basic need for the survival of human beings.

Speech is the most frequently used medium of communication in the life of an individual. It is so because the language in the form of speech, the gift of nature to human beings, is available to every individual and does not cost them a bit to use. Such communications are direct and immediate as the speaker and listener are present at a given place at a given time. It is only when the situation of now and here are not met that the individuals take recourse to writing. Writing requires extra material in the form of paper, ink and writing tools.

## NOTES

It is true that the society is a collection of individuals and the culture and norms in the societies are also made by them. However, there is a constant tension between the individual and society and most of the developments in societies also take place due to this tension. Individuals in the society discuss and debate over the issues to resolve them. The Indian society is divided into various socio-economic classes such as the upper class, middle class and lower class depending upon one's social status. There may be divisions such as those belonging to the *bhadralok* or the *genteel* class and those not belonging to it. A lack of education implies belonging to the non-*genteel* class. The middle class is also termed as the *bourgeois* class to differentiate it from the nobility or aristocracy and the proletariat or the working class. In a capitalist form of society, society is divided based on the ownership of the factors of production, especially capital. Such a society is divided into *haves* and *have-nots*. But the division of classes is arbitrary and mutually inclusive. The society is made up of individuals and not classes, and so communication among all social classes is essential and inevitable. Any conflict that may arise out of differences of opinions or interests has to be solved by communication.

It is the requirement of a healthy society that the individuals communicate at the personal as well as public levels to keep them in harmony at the individual as well as community levels. In earlier days, the narration of the heroic stories, singing and dancing around the bonfire were the part of social communication. We do not talk about political communication within tribal society as the tribes are seen as the extended family. It is in the later stages of social development that the group communication is not possible and we begin to use media of mass communication and other institutions to communicate or negotiate with individuals.

### **Political Communication**

The politics in a society starts when more than two people organize them in some kind of order. In this sense, the smallest unit of political activity could be the family. Politics is the game of negotiating the various interests with those who have the power to govern any type of social order. As a result of this all-pervasive nature of politics, a large part of human communication in modern societies is devoted to what could be named as political communication. Politics and oratory are interrelated. The Roman and Greek orators such as Cicero and Demosthenes were also politicians.

Karl Marx, the German philosopher of the nineteenth century, had claimed that the social class to which one belongs is determined by the role one plays in the production process. He asserted that the present society has been brought about by a series of class struggles, and so, another such form of class struggle will change who owns the factors of production. Such ideas influence people who feel that they have been neglected by those in power. Thus, a Marxist may prefer a government that promises more reforms for the poor.

## NOTES

Most of the scholars of mass communication studies in United States in the initial days of such studies have tried to study the impact of mass media on the political behaviour of the masses. In fact, some of the theories of communication like personal influence theory, cultivation theory, agenda setting theory, dependency theory have been formulated with the subconscious objective of studying the influence of social and political order on individuals and the role of communication or media in achieving it.

The notion of the freedom of press itself speaks about the relations of media and politics. The renowned American journalist and political analyst Walter Lippmann says that press is not a mirror of society, it is like a flashlight which moves restlessly from one episode to another. However, he admits that 'the quality of news about modern society is an index of its social organisation'. Similarly, Noam Chomsky and others have also indicated that the media in modern societies are used for 'manufacturing consent' for the political powers that be.

In fact, political communication has become one of the significant areas of media studies in modern times because the political systems including democracies have undergone many changes in recent times. The role of lobbyists and journalists in governance and politics has been there in many democracies and was not taken as an issue of major concern. In India, the exposure of the conversation between Nira Radia and some journalists has opened up this issue again.

### **Development Communication**

The obsession of media scholars with politics died down when the United Nations, just after the World War II, decided to launch a drive for development. This was the time when any countries had been freed from the clutches of colonialism and breathed the fresh air of freedom. The socio-economic situations of these countries were very pathetic. Hence, it was natural for these nations to take up the task of developing themselves for the betterment of the living conditions of their people.

Nora C. Quebral coined the expression 'Development Communication' in 1972. He explains the field as 'the art and science of human communication linked to a society's planned transformation from a state of poverty to one of dynamic socio-economic growth that makes for greater equity and the larger unfolding of individual potential'. Under development communication, either quantitative surveys are carried out to facilitate communication, or communication is used as an intervention to affect a desired behaviour in an individual or a group of individuals. For example, the use of street plays, skits, billboards, advertisements, etc. in order to promote a particular cause is an example of development communication. The whole idea behind such type of communication is that human behaviour can be positively influenced by frequent reinforcements of a particular idea or design. In broad terms, it implies the use of various channels and means of communication to bring about development.

## NOTES

### Culture and Communication

The relationship of culture and communication is reciprocal because most of the communication is dependent upon social and cultural ethos while the communication also influences and makes changes in the culture by its interventionist character. Denis McQuail in his paper *The Influence and Effects of Mass Media* says about the effects of communications on the political systems:

It is not difficult to appreciate that we can arrive at one or more versions of ways in which culture and social structure can be influenced by the path of development of media institutions. If the content of what we know, our way of doing things and spending time and organisation of central activities for the society are in part dependant on media, then the fact of interdependence is evident.

We already know the much talked about theory of cultivation by George Gerbner (1976). It sees the 'key to the effects of mass media in their capacity to take over the "cultivation" of images, ideas and consciousness in an industrial society'. Gerbner refers to 'the main process of mass media as that of "publication" in the real sense of making public'.

Marshal McLuhan (1964) in his well-crafted book *Understanding Media* indicates the power of mass media to influence the individual and their cultures when he talks about the very popular slogan 'Medium is the message' and then goes on to explain how print, radio, telephone, cinema, typewriter and television have not only provided the new media of communication but it has also changed the social behaviour. In a lighter vein, the best example of medium being message in itself is shown in an advertisement where a person watching Television is asked, 'Is he watching news?' He replies by saying, 'Bullshit, I am watching Television!' But it is true that with each new medium, the human behaviour changes, if the spontaneity of spoken language makes us more emotional then the use of written language makes us more rational and individualistic.

McLuhan's prediction of the global village is the final argument in favour of the significant impact of media. Globalization may not have come because of the emergence of television but in today's globalized world the combination of television and satellite along with the broadband Internet and mobile telephony has certainly created a ground for free international market and increasing globalization of linguistic and cultural life of the people.

Mass media makes it possible for indigenous culture to reach a mass audience. In fact, traditional media relies to a great extent on the cultural elements of a society. For example, TV shows such as *India's Got Talent* promote indigenous culture. Culture and communication are inseparable because culture depends upon communication for its survival and perpetuity.



### **Check Your Progress**

3. What is the most frequently used medium of communication in the life of an individual?
4. What is politics?
5. Who coined the term development communication?

### **NOTES**

---

## **1.4 TYPES OF COMMUNICATION**

---

Human beings communicate in many different ways for achieving different results. Sometimes human beings do not feel the need of another person to perform the act of communication. People generally talk to each other or write letters and books to talk about various issues and subjects. There are also situations where people talk to each other in groups as in the case of business meetings or classrooms. There are acts of communication where one person talks to many, where it is not easy to get or understand the response or feedback of the audience.

In this section, we would discuss various kinds of communication so that the complete range of human communication could be described. The story of human communication begins with intrapersonal communication and then we find interpersonal, group and mass communication as other kinds that relate to the growth of society.

### **Intrapersonal Communication**

Human beings have the gift of language which helps them to communicate with each other. The same system of language has given them the facility to talk to themselves. The whole process of thinking in human beings can be considered as communicating to themselves. This kind of communication is called intrapersonal or auto-communication. Intrapersonal communication is in fact a reflexive process which is very significant for thinking, conceptualizing and formulating ideas before they could be used for other types of communication.

There are many examples of interpersonal communication in our daily life. For example, we often come across monologues in literature, especially in drama and we also find people indulging in loud thinking. The tendency of loud thinking becomes abnormal when it almost becomes a habit. In many societies people talk to themselves in public as they are either very tense or they feel alienated.

In fact, if we look at interpersonal communication from the time life occurred on earth, we could observe that all living mechanisms starting from amoeba have the need to talk to themselves for their very existence. In this sense all physio-cerebral communications could be viewed as intrapersonal communication.

## NOTES

However, in communication studies we only include human communication that takes place with the help of some kind of sign system like language.

Dream is one such communication which is very common where one does not only use the language in the form of dialogues with the characters one sees in the dream, but a large part of dream is made up of series of visuals like a film that we have recorded in our brain in the conscious state.

### **Interpersonal Communication**

Interpersonal communication is the most usual form of communication. In every society individuals indulge in various kinds of social relationships that could not be sustained without talking to each other. It is to establish this link between them that human beings, in a way, invented language system that uses jaws and vocal cords to articulate signals that could be transmitted to the ear which then decode it to get the meaning.

As interpersonal communication takes place between two or more persons when they are present at a given place at a given time, it is not only the language that communicates, even the facial expression, gestures, postures, hair styles, dress, etc., become potent source of information. In fact, human beings have been using all their five senses to receive different kinds of information available around them. These senses keep working all the time in the conscious state of mind. The conversation that you have every day with your family members is a kind of interpersonal communication.

Starting from our primitive days of existence, interpersonal communication has become the backbone of all human development. Even in this age of heightened literacy the significance of interpersonal communication has not diminished because it is the only form of communication that is very natural and allows people to have the immediate feedback of the messages transmitted by them.

The proximity between the people involved in communication also evokes a certain emotivity which in turn helps them to encourage, motivate, influence and persuade people. It also helps them to effectively coordinate their activities and works. It is difficult to imagine the absence of interpersonal communication in societies as a large part of human activity is such which involves people doing things together. For example, construction of buildings would become impossible if people could not communicate because construction is a group activity.

### **Group Communication**

In a way any communication between more than two persons can be seen as a group communication, but any communicative situation in a family or friends is generally seen as interpersonal communication because these are not always intentional or organized. Hence, we can say that group communications occurs when people gather intentionally or when an act of communication in group is organized with a particular objective in mind.

## NOTES

Group communication has been there since the human societies moved out of the wildlife state to organize them into tribes. In fact, the transition of homo sapiens from individual families to tribes may be seen as the beginning of social organization where communication started playing a major role as they found a higher form of communication than its earlier form of interpersonal communication. One could recall the newer forms of odes, folk songs and storytelling devised by tribal societies to perpetuate their traditions and to glorify their ancestor heroes.

In the later days of human civilization, we find the religious gatherings like prayer meetings, educational endeavours, public or private court meetings of kings and public meetings in modern democracies as the newer forms of group communication. In modern times, individual family business or multinational corporate business, national governance and international relations cannot be imagined without various forms of group communications. The meeting of the board of governors, the parliament sessions, the group of ministers' meetings, national and international conferences, and conventions and summits are all examples of group communication. In our daily lives, when we are sitting with our family and sharing our everyday experiences and opinions about life, we are involved in group communication. Also, a group of friends chatting is also a form of group communication.

The sitting arrangements for group communication have their own significations. Podium and audience arrangement generally does not allow two way communications; it would normally be useful for top-down communication. Board meeting arrangement of round table conferences on the other hand allows an equal level two-way dialogue between the groups.

### **Mass Communication**

Mass communication is not merely an extension of group communication, it also involves heterogeneous masses. What makes interpersonal and group communication similar to each other is the homogeneity of the audiences. People involved in such communication not only share the code of communication, they by and large share thought process, culture and attitudes too. The feedback process of these types of communication is also different as the feedback is immediate in interpersonal and mass communication, whereas the feedback is delayed and more complex in mass communication as different type of mass media are used for transmitting the messages to masses.

*Handbook of Journalism and Mass Communication* defines mass communication as 'a process of delivering information, ideas and attitudes to a sizable and diversified audience through use of media developed for that purpose.' Mass communication is a one-way communication in the sense that it is one-to-many kind of communication whereas interpersonal communication is most of the times one-to-one communication. What makes mass communication interesting and challenging is the very fact that it is one-to-many type of communication where the sender may think or pretend knowing his/her audience but is never sure to

## NOTES

whom all he/she is communicating. The challenge of mass communication alone has forced people concerned or involved in it to study the nature, attitudes, demography, etc., of the audience as scientifically as possible. The shift of journalism studies from language departments to independent interdisciplinary discipline is a result of the complexities of mass communication.

The role of mass media is very significant in a society. Harold Lasswell, a prolific communication scholar, suggested that the media perform four basic functions for society: surveying the environment to provide information; correlating response to this information (editorial function); entertaining the media user (diversion function); and transmitting the country's cultural heritage to future generations (socialization or educational function). In a developing country, the mass media are also expected to play an additional role – to mobilize public support for national development.

### Check Your Progress

6. List some examples of interpersonal communication.
7. What type of communication has become the backbone of all human development?

---

## 1.5 ANSWERS TO CHECK YOUR PROGRESS QUESTIONS

---

1. The word 'communication' is derived from the Latin word 'communicatio' or 'communicare' that means communicate, discuss, impart or share.
2. The technical view defines communication simply as 'sending and receiving messages' or 'the transmission of messages'.
3. Speech is the most frequently used medium of communication in the life of an individual.
4. Politics is the game of negotiating the various interests with those who have the power to govern any type of social order.
5. Nora C. Quebral coined the expression 'Development Communication' in 1972.
6. There are many examples of interpersonal communication in our daily life. For example, we often come across monologues in literature, especially in drama and we also find people indulging in loud thinking. The tendency of loud thinking becomes abnormal when it almost becomes a habit. In many societies people talk to themselves in public as they are either very tense or they feel alienated.

7. Starting from our primitive days of existence, interpersonal communication has become the backbone of all human development.

---

## **1.6 SUMMARY**

---

- The process of communication has played a vital role in the evolution of life on earth.
- Communication is also an interdisciplinary subject. It encompasses literature, sociology, psychology and statistics.
- Communication is also an interdisciplinary subject. It encompasses literature, sociology, psychology and statistics. For example, when we talk to our friends, we talk about a variety of subjects of interest.
- Societies cannot be imagined without communication nor is there any communication without society or individuals. Communication being one of the important needs of the society has developed from speech to Internet to facilitate the process of human development.
- Communication for people is as normal and necessary activity as breathing or eating food. Every one of us needs to talk to people immediately after we get up and people around us also want to tell us something or the other throughout the day.
- Human beings need to communicate to fulfil their basic needs as well as to make them aware about their surroundings and society in which they live.
- It is the requirement of a healthy society that the individuals communicate at the personal as well as public levels to keep them in harmony at the individual as well as community levels.
- The relationship of culture and communication is reciprocal because most of the communication is dependent upon social and cultural ethos while the communication also influences and makes changes in the culture by its interventionist character.
- The story of human communication begins with intrapersonal communication and then we find interpersonal, group and mass communication as other kinds that relate to the growth of society.
- Intrapersonal communication is in fact a reflexive process which is very significant for thinking, conceptualizing and formulating ideas before they could be used for other types of communication.
- Interpersonal communication is the most usual form of communication. In every society individuals indulge in various kinds of social relationships that could not be sustained without talking to each other.
- As interpersonal communication takes place between two or more persons when they are present at a given place at a given time, it is not only the

## **NOTES**

## NOTES

language that communicates, even the facial expression, gestures, postures, hair styles, dress, etc., become potent source of information.

- We can say that group communications occurs when people gather intentionally or when an act of communication in group is organized with a particular objective in mind.
- Mass communication is defined as a process of delivering information, ideas and attitudes to a sizable and diversified audience through use of media developed for that purpose.
- Mass communication is a one-way communication in the sense that it is one-to-many kind of communication whereas interpersonal communication is most of the times one-to-one communication.

---

### 1.7 KEY WORDS

---

- **Bourgeois:** It means belonging to or characteristic of the middle class, typically with reference to its perceived materialistic values or conventional attitudes.
- **Speech:** It is the expression of or the ability to express thoughts and feelings by articulate sounds.
- **Skits:** It is a short informal performance intended to educate or inform.
- **Globalization:** It is the process of interaction and integration between people, companies, and governments worldwide.
- **Homo Sapiens:** It refers to the species to which all modern human beings belong.

---

### 1.8 SELF ASSESSMENT QUESTIONS AND EXERCISES

---

#### Short-Answer Questions

1. How is communication both an art and a science?
2. Define communication.
3. Write a short note on political communication.

#### Long-Answer Questions

1. Examine the individual and social need for communication.
2. Discuss the relationship between culture and communication.
3. Describe the different types of communication.

---

## 1.9 FURTHER READINGS

---

- Schramm, Wilbur. 1966. *The Science of Human Communication*. Illinois: The Business Press.
- Rosengren, Karl Erik. 2000. *Communication: An Introduction*. London: Sage Publication.
- Fiske, John. 1988. *Introduction to Mass Communication*. London: Routledge.
- Berger, Arthur Asa. 1997. *Essentials of Mass Communication Theory*. Thousand Oaks, CA: Sage Publications.
- McQuail, Denis. 1983. *Mass Communication Theory*. London: Sage Publications.
- Hanson, Jarice. 1994. *Connections: Technologies of Communication*. New York: Harper Collins Publishers.
- William, Reymonds. 1994. *Invention of Communication*. New Delhi: Sage Publications.

## NOTES

NOTES

---

## UNIT 2 BASIC MODELS OF COMMUNICATION

---

### Structure

- 2.0 Introduction
- 2.1 Objectives
- 2.2 Linear Model
- 2.3 Non-linear Model
- 2.4 Answers to Check Your Progress Questions
- 2.5 Summary
- 2.6 Key Words
- 2.7 Self Assessment Questions and Exercises
- 2.8 Further Readings

---

### 2.0 INTRODUCTION

---

Communication as an activity appears to be very simple to explain at the very first instance, but when we explore it further the complexities of communication make it difficult for us to describe it in simpler terms. There have been many models that explain the various aspects related to communication. In a simple sense, a model is any representation of a theory, idea or concept that takes into account any studies that have already been done, and lays the foundation for further studies on the subject. According to C. David Mortensen, author of *Communication: The Study of Human Communication* 'In the broadest sense, a model is a systematic representation of an object or event in idealized and abstract form. Models are somewhat arbitrary by their nature. The act of abstracting eliminates certain details to focus on essential factors. The key to the usefulness of a model is the degree to which it conforms – in point-by-point correspondence – to the underlying determinants of communicative behaviour.'

The models of communication help us to understand the process of communication where the factors of communications are shown in a particular order and relations. In this section, we would look at various models of communication suggested by different scholars from time to time.

It is worth mentioning here that we find two distinct types of models of communication, i.e., linear and non-linear. The model suggested by Shannon and Weaver is the first model of communication, though it was drawn by them to explain the working of telephones. Linear models of communication are a one way model to communicate with the others, and involves sending a message to the receiver. It does not take the feedback of the receiver into account. In a linear model, the beginning and end of the communication process are clearly defined. The linear models see communication as the transmission of message and



consequently raise the issue of effect rather than meaning. A situation of communication gap can only occur if we look at communication as a process of the transmission of message. Non-linear model of communication is a two way model of communication that takes the response or feedback of the receiver of the message into account. Another name of this kind of model is circular or interactional model.

## NOTES

---

### 2.1 OBJECTIVES

---

After going through this unit, you will be able to:

- Describe the linear model of communication
- Explain the non-linear model of communication

---

### 2.2 LINEAR MODEL

---

Let us begin by discussing the linear model of communication.

#### Shannon and Weaver's Model (1948)

Claude Elwood Shannon published a paper in two parts *A Mathematical Theory of Communication* in 1948. In this paper, he developed the concept of information entropy, which worked as a measure for the uncertainty in a message. He was essentially inventing something else that later on became the dominant form of 'information theory'. Warren Weaver afterwards made his theory available to people in simpler versions and was subsequently used by scholars widely in social sciences. Many years later the same theory was published in a book co-authored by Weaver. Hence the model was named as Shannon and Weaver model by social scientists though it appeared for the first time in the original paper of Claude Shannon in 1948. Figure 2.1 presents the basic elements contained in this model.

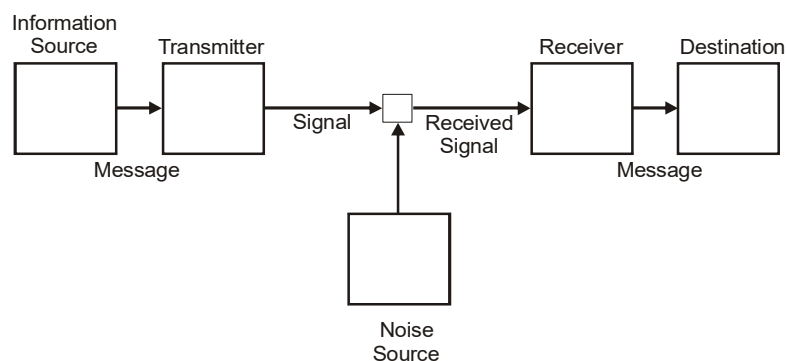

*Fig. 2.1 Schematic Diagram of a General Communication System*

The model when used in communication studies would mean that the communication begins with the information source or sender who creates a message.

## NOTES

This message is then transmitted along a channel. The role of transmitter is to convert the messages into signals that are capable of being transmitted through a channel. The signals so received are then reconverted to the original message by the receiver so as to reach the destination. Shannon in this model very significantly discusses the role of noise. The noise in his model refers to disturbances in the channel that may interfere with the signals and may produce the signals that were not intended. Shannon also elaborates on the role of redundancy and entropy as the major concepts of communication because they help in overcoming the disturbances caused by the channels.

In his paper Shannon discusses the terms entropy and redundancy in the following words:

The ratio of the entropy of a source to the maximum value it could have while still restricted to the same symbols will be called its *relative entropy*. This is the maximum compression possible when we encode into the same alphabet. One minus the relative entropy is the *redundancy*. The redundancy of ordinary English, not considering statistical structure over greater distances than about eight letters, is roughly 50%. This means that when we write English half of what we write is determined by the structure of the language and half is chosen freely.

The model of Shannon and Weaver is interpreted a bit differently by scholars of communication studies with social science background. It is for the same reason that the model of David Barlow becomes important where the mathematical technicalities of Shannon's models were reinterpreted for human communication process.

### Harold Lasswell's Model (1948)

Harold Dwight Lasswell (1902–1978) was a leading American political scientist and communications theorist. He was the Chief of the Experimental Division for the Study of War Time Communications at the Library of Congress during the Second World War. He analysed Nazi propaganda films to identify mechanisms of persuasion used to secure the acquiescence and support of the German populace for Hitler. He gave verbal models of communication and politics in the same year when Shannon wrote his paper on mathematical theory. His model of communication is in the shape of a question containing many more questions.

**Who** says

**What** to

**Whom** in

**What Channel** with

**What effect?**

This linear model enumerates main variables involved in the process of communication. The 'Who' refers to the identification of the source and 'What'

refers to the analysis of the content of the message. The choice of channel is denoted by the question ‘What channel’ and the characteristics of the audience by the question ‘Whom’. The main thing about this model is that it makes the end result of communication as the most important aspect of the whole process, when Lasswell asks ‘What effect?’ In a way, this model of communication appears to be influenced to a large extent by the behaviourism which was the newly developing trend in America those days. Behaviourism is a school of psychology that supports that behaviours can be influenced by conditioning. Laswell’s model takes the psychological conditioning of individuals and society into account. His model of communication can also be described as the psycho-sociological model of communication because it deals with the psychological and sociological aspects of communication. It considers what effects communication has on the recipient(s) of the message, and so it enters the domain of psychology as well as sociology.

## NOTES

### David Berlo’s Model (1960)

David Berlo’s model is popularly known as SMCR model. As has been said earlier, it is the socio-cultural extension of the mathematical model of communication given by Shannon and Weaver.

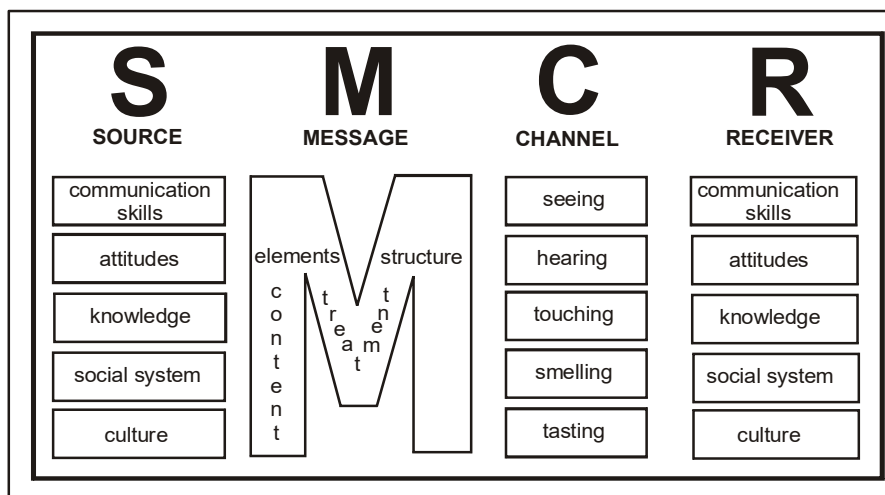

*Fig. 2.2 David Berlo’s Model of Communication (1960)*

Berlo says that the source and destination, i.e., the speaker and listener should share certain elements in order to achieve successful communication. The elements that they should share are described as communication skill, attitudes, knowledge, social system and culture. Similarly, he has also found more elements in ‘message’ and ‘channel’. The elements of message are content, element, structure, treatment and code. Further, the elements within ‘channel’ have been seen as the five sense perceptions, i.e., seeing, hearing, touching, smelling and tasting. Berlo has also described each element of SMCR in great detail. The S in the model stands for source which may be oral, written, electronic or even symbolic. The M denotes the message that is transmitted and it implies the dissemination of ideas.

The C indicates the channel through which communication is affected. Since the receivers are the one towards whom the communication process is directed, so, they are denoted by R in the model.

## NOTES

### Check Your Progress

1. When did Claude Shannon publish his concept of information entropy?
2. Who was Harold Lasswell?

## 2.3 NON-LINEAR MODEL

Let us now discuss the non-linear communication models.

### Theodore M. Newcomb's Model (1953)

Theodore M. Newcomb was an American social psychologist who carried out work in the area of interpersonal attraction. Newcomb's model is unique in the sense that unlike other models he has given a triangular one which tries to explain the role of communication in a society.

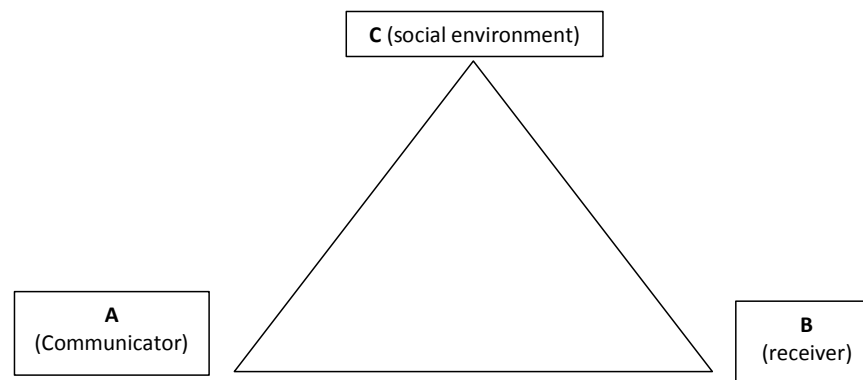

*Fig. 2.3 Newcomb's Model (1953)*

The three nodes of the triangle A, B, C represent communicator, receiver and their social environment, respectively. According to him, the ABC elements form a system where there is a relationship of interdependence between the three. It means that if A changes, B and C would also have to change. In case A changes its relationship with C, then B will have to change its relationship with C or A as well. The corresponding changes will maintain the equilibrium within the system. C here denotes social environment which is both common to A and B. Communication takes place between the two in a symmetrical manner because they are both oriented towards C. Communication supports this structure and relationship, and so, if there is a change or adjustment in relationship between A and B, a symmetry can be created without disturbing the communication equilibrium.

Let us take the example of an election where A is a political party, B is the people and C is the election itself. A and B need to relate with each other in the context of election. This relation or connectivity is achieved by both with the help of various kinds of media and the result of elections would depend on how much A has been able to influence B. If the communication is successful the result of the election would be in the favour of A or else they would go against A. In either case, the relationship between A and B would change because the environment C has changed in a definitive manner.

In a way, this model can be compared with the sociological theory of the state of equilibrium. It is a model which underlines the significance of communication in an era of information where people believe in the power of knowledge and where the political parties, governments and the people depend heavily on news and information in order to provide or get good and effective governance. This good governance requires democratization of public policy which cannot be achieved without intense communication.

### Charles E. Osgood's Model (1954)

Charles Egerton Osgood was an American psychologist who is known for his contribution of developing a technique of measuring the connotative meaning of concepts, known as the semantic differential. He has also contributed insights into the area of psycholinguistics. In fact, Charles Osgood is the first person to underline the two-way nature of communication which makes it a very good model to understand the actual process of interpersonal communication. Osgood has also talked about one-to-many and many-to-one systems of communication while elaborating his model. Osgood made a new beginning in communication models by suggesting the first circular model as it does not look at communication as a linear process moving from point A to point B. Communication is a dynamic process for him which can begin with any stimulus received by the source or receiver. His model shows the significance of both the source and receiver as the participants in a communicative situation. In his model, both the ends have the capability of encoding, decoding and interpreting the messages.

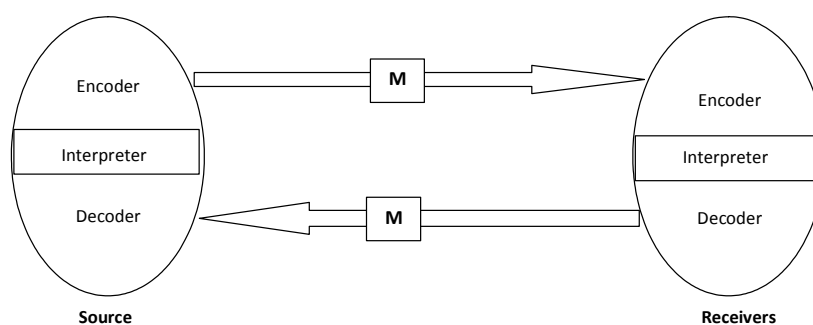

Fig. 2.4 Osgood's Communication Model

## NOTES

## NOTES

Writing about his model in his book the *Measurement of Meaning*, Osgood says:

... we have communication whenever one system, a source, influences the state or actions of another system, the destination or receiver, by selecting among the alternative signals that can be carried in the channel connecting them. In dealing with human communication systems we usually refer to signal sets as messages; and these are most often, though not necessarily, language messages. ... Also in dealing with human communication, it is necessary to further analyze both source and receiver into integrated subsystem. The individual human communicator is equipped both to receive and transmit messages more-or-less simultaneously – indeed, he is regularly the receiver of the message he himself produces, via feedback mechanism.

### George Gerbner's Model (1956)

Another linear model of communication proposed by George Gerbner, former Professor and Head of the Annenberg School of Communication in the University of Pennsylvania, tries to take the best of all the earlier models that judge communication as the transmission of message. His model, in fact, tries to improve upon the earlier models. The unique feature of this model is that it relates the message with the reality and thereby raises the question of perception and meaning.

Gerbner's model has two dimensions and three stages. The perceptual or receptive and the communicative and means of control are the two dimensions and the vertical, horizontal and then vertical again are the three stages in this model. The elements used in Gerbner's model are given in the figure below (Figure 2.5).

In order to explain, this model we will discuss it thread bare from first stage to the last stage. To begin with, the first stage called Horizontal Dimension, one has to start from the event E (external reality) as perceived by M (the human being or the machine such as a camera or a microphone). M then selects E according to his perception of the event. As human perception is a very complex phenomenon, it involves a series of interaction and negotiation. This is the complete process of arriving at some perception of the event by matching the external stimuli with the internal pattern of thought or concept.

The vertical dimension is the second stage where the perceived reality is articulated with the help of a mechanism that converts E into signals that are capable of being transmitted along a channel. Here the E is converted into SE which we normally call as message. In this stage, it becomes necessary to select the appropriate means or the medium of communication. Gerbner is actually illustrating the notion of access to media at this point. Let us take the example of television as media to understand the question of access. Television is generally considered as the elitist media.

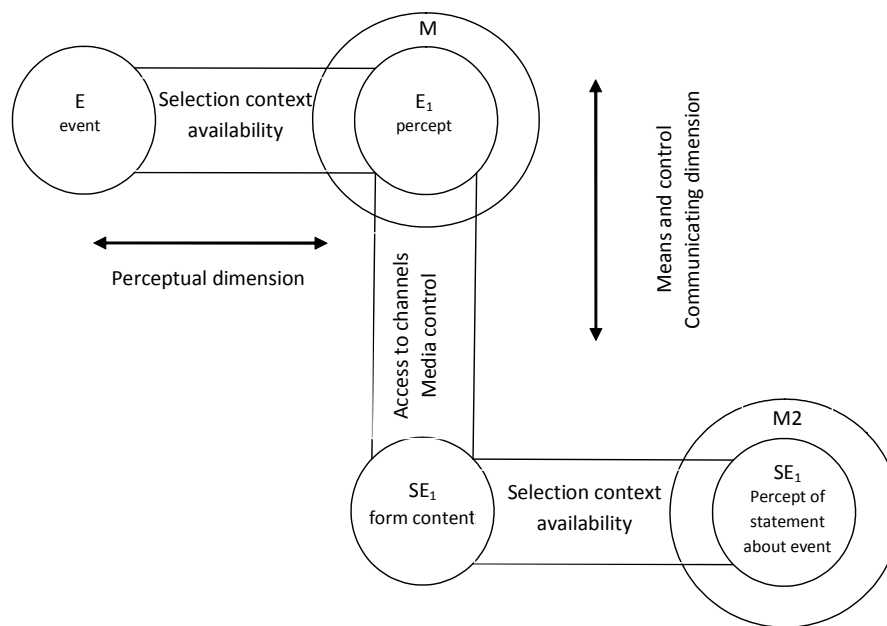

## NOTES

*Fig. 2.5 Gerbner's Model*

The third stage of this process is where the message reaches its destination. This again has the horizontal dimension where M<sub>2</sub> is the signal or statement SE about the event E. Here the meaning of the message is not contained in the message itself, but it is arrived at through interaction and negotiation that takes place between the message and the receiver. Gerbner introduces here the concept of culture and says that the receiver derives the meaning of SE on the basis of his culture or sub-culture which again requires the interactions and/or negotiations between M<sub>2</sub> and SE resulting in the generation of meaning of SE. For example, there is a witness (M) to a case (E). He is bound to be affected by his attitude, behaviour, perception, and so, his statement is converted into SE. His mode of communication is through written or oral form. This SE is taken up by the media house that converts it into a news report (M<sub>2</sub>). The readers of the news at this point form their opinions based on their own cultural aspects and orientations. Thus, meaning is generated in this way.

This model brings forth two important concepts of access and availability. As we have described earlier, the selection of reality in television is in the control of the persons who control that media. It is for the same reason that the trade unions across the world accuse the owners of the media and the middle class intellectuals of misrepresenting the workers agitation in particular and the industrial news in general. Hence, access to media is a means of exerting power and social control. At horizontal dimension, availability does something almost same as what access does to the reality in vertical dimension. If selectivity tries to interpret the reality in terms of a given perspective, then the availability helps to determine what is actually perceived. At this level, the receiver of the message uses his own selectivity that is the end result of his socio-cultural environment. It is amply clear

by the fact that the working class is able to understand the bias and misrepresentation of reality portrayed by the mainstream media because of the differences in the sub-cultures of the encoder and the decoder.

## NOTES

### **Revised Model**

George Gerbner later presented a modified version of his model which includes human and mechanical agents involved in the process. His later works like his studies of violence on television suggests that he was aware of certain deficiencies in his model, but the significance of his work lies in the fact that he has tried to synchronize the process and semiotic school of studies in his model. Later, Gerbner adopted a new approach to the study of mass communication, focussing on the process of mass communication itself. Gerbner, Gross, Morgan, & Signorielli asserted that television is the new form that disseminates new images and messages in the world. It determines the new social trends, and has replaced other forms of media, thus creating a new symbolic environment. It affects the thinking of the people, but Gerbner also argues that the effects of television are limited.

### **Wilbur Schramm's Model (1971)**

Wilbur Schramm was one among the leading experts in the field of communication studies. He has very effectively tried to explain the process of communication in its widest sense from intrapersonal to mass communication. He has improvised the model of Shannon and Weaver and has also made Osgood's model more effective by introducing the notion of feedback. The stress on feedback and noise as the essential components of communication process is an improvement upon Osgood's concept of the source and receivers both possessing the encoding, interpreting and decoding capabilities.

The feedback becomes a very important factor for the two-way communication between two people where any further possibility of sender's encoding of another message depends upon the constant feedback in terms of the response. Hence, a dialogue is a communication where two people talking to each other become the sender and receiver at the same time. Schramm also interpreted feedback in another way where it means that the encoder gets the response from his/her own message. We always hear our own voice while speaking and read our own writings before they are heard or read by others. The process of correcting the pronunciation and spelling are the result of the feedback mechanism between the encoding and the message. In this sense, the sender alone is having both functions of encoding and decoding for his/her own message.



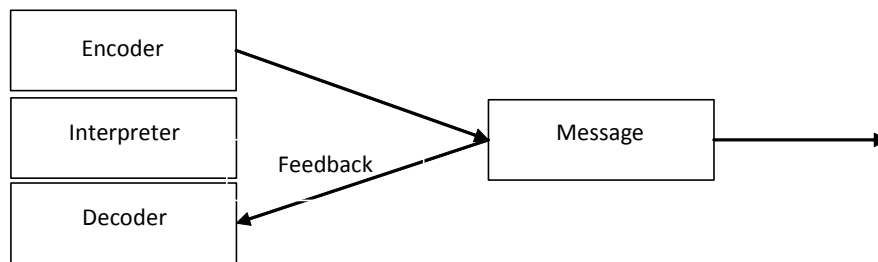

**Fig. 2.6** Schramm's Communication Model

Schramm then brings the notion of field of experience as a significant factor of communication. The large part of the field of experience of the people is idiosyncratic or private. However, the medium and a part of the field of experience should be shared by the individual without which communication cannot take place.

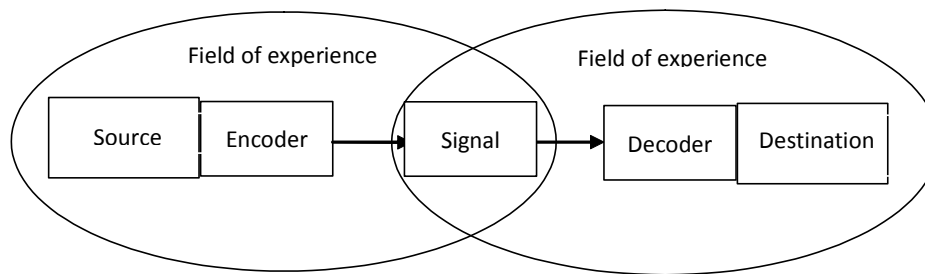

**Fig. 2.7** Field of Experience in Communication

He also discusses the role of frame of reference for the people participating in communicative situation. The frame of reference is the total sociological context in which the communication takes place and where the people relates to the messages on the basis of their own values, needs and the social imperatives and constraints imposed on individuals.

### **Westley and MacLean's Model (1957)**

Bruce H. Westley and M.S. MacLean gave an improvised and extended version of Newcomb's model. If Newcomb's model was for communication in general then this model is specifically adapted and designed for understanding the role of mass media in communication. Westley and MacLean have added one more element of editorial-communicating function to the triangular model of sender, receiver and their social context.

## **NOTES**

NOTES

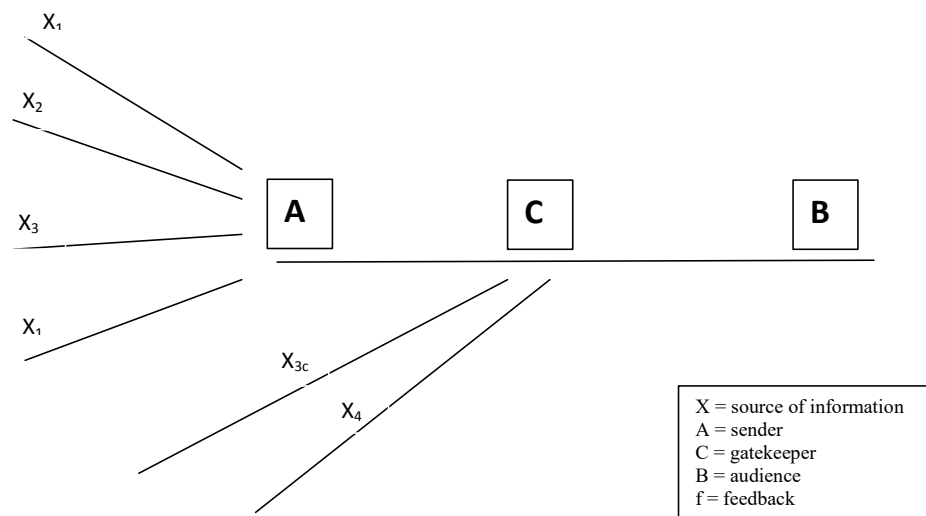

**Fig. 2.8** Westley and MacLean Model of Communication

In Figure 2.8, C stands for the gatekeeper, B represents the audience members, and A stands for the sender, or individuals who want to communicate something to the others. The X represents the external surroundings that are also the source of information.

C is placed in middle of A and B because it acts as the gatekeeper who decides what information given by A will be shared with others and what will not be shared. The newspapers, websites and other media have limited space and time in comparison to the stories that they could find out. The gatekeeper believes that it knows the needs of the audience well, and so decides for them the information that will reach them. It tries to understand their needs by devoting time to this process.

The element of feedback between C and B is equally important in the model. This involves the audience providing feedback to the gatekeeper about their needs. At the same time, C will give feedback to A to tell him what the audience or B wants.

For example, at a news channel, the gatekeepers decide what to broadcast on the channel because they have enough experience to know the viewers' needs well. A reporter who works with the news house will be required to find stories that could be passed to the audience in the form of a broadcast. But a reporter also needs to receive feedback from his editor or producer to know what the viewers want. Similarly, the news channel has several competitors and would not like to lose its viewership, so it will make sure that it understands the needs of its viewers perfectly well.

According to their scheme of things, the receiver of the message gets what the communicator wants him/her to receive. It is so because many a times they do not have any information about the facts that are told. For explaining this Westley

and MacLean dragged axis X to such an extent that the triangular model becomes linear. The other important aspect of their model is that they have revised it to extend it further the first-layer talks about the relationship of receiver with the sender and the social environment and the second layer involves a mass media or an editor who mediates between the two. An example of the Westley and MacLean's model is that in case a person witnesses an accident, his first reaction would be to communicate this piece of information to his family and dear ones to make sure that they are all right. In this case, he received signals from his environment and passed the gathered information to others. Thus, communication is derived from the external surroundings. In this example, the individual has acted as the gatekeeper who chooses how to give the piece of information to the audience.

Westley and MacLean argue that mass media has expanded our world so much that we by ourselves cannot obtain all the information required by us and it is here that the role of mass media and journalists appears as they provide the necessary orientation. In this scheme of things, the sender and the mass media can play dominant role and the receiver becomes totally dependent on them for the information and orientation to avoid the possible disconnect that could be caused otherwise. Thus, theirs is a dependency model that fails to take into account the fact that mass media is not the only means of orientation towards the reality and people have other means too. We all have family, friends, school, religious places, social institutions, work places and various types of organizations which on regular basis supply us with information and orientation.

### Check Your Progress

3. Who was Theodore Newcomb?
4. What is Charles Osgood best known for?
5. What are the dimensions and stages of Gerbner's model?

---

## 2.4 ANSWERS TO CHECK YOUR PROGRESS QUESTIONS

---

1. Claude Elwood Shannon published a paper in two parts A Mathematical Theory of Communication in 1948. In this paper, he developed the concept of information entropy, which worked as a measure for the uncertainty in a message.
2. Harold Dwight Lasswell was a leading American political scientist and communications theorist.
3. Theodore M. Newcomb was an American social psychologist who carried out work in the area of interpersonal attraction.

## NOTES

## NOTES

4. Charles Egerton Osgood was an American psychologist who is known for his contribution of developing a technique of measuring the connotative meaning of concepts, known as the semantic differential.
5. Gerbner's model has two dimensions and three stages. The perceptual or receptive and the communicative and means of control are the two dimensions and the vertical, horizontal and then vertical again are the three stages in this model.

---

## 2.5 SUMMARY

---

- There have been many models that explain the various aspects related to communication.
- In a simple sense, a model is any representation of a theory, idea or concept that takes into account any studies that have already been done, and lays the foundation for further studies on the subject.
- Claude Elwood Shannon published a paper in two parts A Mathematical Theory of Communication in 1948. In this paper, he developed the concept of information entropy, which worked as a measure for the uncertainty in a message. He was essentially inventing something else that later on became the dominant form of 'information theory'.
- Warren Weaver afterwards made his theory available to people in simpler versions and was subsequently used by scholars widely in social sciences.
- Shannon and Weaver's Model when used in communication studies would mean that the communication begins with the information source or sender who creates a message. This message is then transmitted along a channel.
- The model of Shannon and Weaver is interpreted a bit differently by scholars of communication studies with social science background. It is for the same reason that the model of David Barlow becomes important where the mathematical technicalities of Shannon's models were reinterpreted for human communication process.
- Lasswell's linear model enumerates main variables involved in the process of communication. The 'Who' refers to the identification of the source and 'What' refers to the analysis of the content of the message.
- David Berlo's model is popularly known as SMCR model. It is the socio-cultural extension of the mathematical model of communication given by Shannon and Weaver.

- Newcomb's model is unique in the sense that unlike other models he has given a triangular one which tries to explain the role of communication in a society.
- Newcomb's model can be compared with the sociological theory of the state of equilibrium. It is a model which underlines the significance of communication in an era of information where people believe in the power of knowledge and where the political parties, governments and the people depend heavily on news and information in order to provide or get good and effective governance.
- Charles E. Osgood made a new beginning in communication models by suggesting the first circular model as it does not look at communication as a linear process moving from point A to point B. Communication is a dynamic process for him which can begin with any stimulus received by the source or receiver.
- Osgood's model shows the significance of both the source and receiver as the participants in a communicative situation.
- Gerbner's model has two dimensions and three stages. The perceptual or receptive and the communicative and means of control are the two dimensions and the vertical, horizontal and then vertical again are the three stages in this model.
- George Gerbner later presented a modified version of his model which includes human and mechanical agents involved in the process.
- Bruce H. Westley and M.S. MacLean gave an improvised and extended version of Newcomb's model. If Newcomb's model was for communication in general then this model is specifically adapted and designed for understanding the role of mass media in communication.

## NOTES

---

### 2.6 KEY WORDS

---

- **Medium:** It is one of the means or channels of general communication, information or entertainment in society, e.g., newspapers, radio or television.
- **Channel:** It is a route through which anything passes or progresses; a path for the transfer of signals or data.
- **Message:** It is a communication containing some information, news, advice, request or the like, sent by messenger, radio, telephone or other means.
- **Encoding:** It is the process of converting a message, information, etc., into code.
- **Decoding:** It means to translate data or a message from a code into the original language or form, to extract meaning from spoken or written symbols.

---

## 2.7 SELF ASSESSMENT QUESTION AND EXERCISES

---

### NOTES

#### Short-Answer Questions

1. What is the significance of the mathematical model of communication in the communication studies?
2. What is the difference between Shannon and Weaver's model, SMCR model and Lasswell's model?
3. Why is Theodore Newcomb's model unique?

#### Long-Answer Questions

1. Describe the SMCR model and its various elements.
2. Give a detailed description of Osgood's model of communication and explain its significance.
3. How is the model of George Garbner different from the rest of the models? Discuss its unique characteristics with examples.

---

## 2.8 FURTHER READINGS

---

- Holmes, David. 2005. *Communication Theory: Media, Technology and Society*. London: Sage Publishers.
- Hartley, John. 2002. *Communication, Culture and Media Studies: The Key Concepts*. New York: Routledge.
- Rosengren, Karl Eric. 2000. *Communication: An Introduction*. London: Sage Publishers.
- Fiske, John. 1982. *Introduction to Communications Studies*. London: Methuen & Co.
- Asa Berger, Arthur. 1995. *Essentials of Mass Communication Theory*. Thousand Oaks, CA: Sage Publications.
- Mcquail, Denis. 1983. *Mass Communication Theory*. London: Sage Publication.
- Schramm, Wilbur. 1966. *The Story of Human Communication*. New York: Harper and Row Publishers.
- William, Raymond. 1976. *Communications*. London: Penguin Books.

---

## UNIT 3 COMMUNICATION AND CULTURE

---

### NOTES

#### Structure

- 3.0 Introduction
- 3.1 Objectives
- 3.2 Communication, Culture and Media Literacy
  - 3.2.1 Media Literacy
  - 3.2.2 Internet and Society
  - 3.2.3 Impact of Media on Politics
  - 3.2.4 Media Education
  - 3.2.5 Business and Culture
- 3.3 Answers to Check Your Progress Questions
- 3.4 Summary
- 3.5 Key Words
- 3.6 Self Assessment Questions and Exercises
- 3.7 Further Readings

---

### 3.0 INTRODUCTION

---

In the previous unit, you learnt about the different models of communication. In this unit, the discussion will turn towards communication and culture.

The term ‘culture’ refers to the complex collection of knowledge, folklore, language, rules, rituals, habits, lifestyles, attitudes, beliefs, and customs that link and give a common identity to a particular group of people at a specific point in time. Its relationship with communication is extremely complex. One should understand that cultures are created through communication; that is, communication is the means of human interaction through which cultural characteristics—whether customs, roles, rules, rituals, laws, or other patterns—are created and shared. Without communication, it would be next to impossible to preserve and pass along cultural characteristics from one place and time to another. Thus, it can be said that culture is created, shaped, transmitted, and learned through communication.

---

### 3.1 OBJECTIVES

---

After going through this unit, you will be able to:

- Discuss the relationship between culture and communication, as well as business and culture
- Describe the concept of media literacy
- Explain the impact of media on business

---

## 3.2 COMMUNICATION, CULTURE AND MEDIA LITERACY

---

### NOTES

Communication is the process of making meaning. The study of communication suggests that through language and communication we define and shape our social and cultural world.

According to some sociologists, we are fast approaching the emergence of a global culture. The sociologists point out that while cultural diversity still exists, there are strong similarities both at macroscopic and microscopic levels. Cultures start resembling each other due to cultural diffusion. Cultural diffusion refers to the spread of standards from one culture to the other. This is not a new phenomenon. Trade, travel and colonization had led to diffusion and influence of different cultures earlier. What has changed now is the rate of diffusion. Increased international travel and improved global communication has led to a greater rate of cultural diffusion. The term 'global village' has been introduced into the vocabulary owing to these developments. This also indicates the shrinking of cultural boundaries and the emergence of a global culture. A term like 'global village' also implies that the world is growing smaller every day.

### **Global Village – A Paradoxical Concept**

Marshall McLuhan said that the electronic age had sealed the whole world as one 'global' tribe. Sitting in the living room, whether at Chicago or New Delhi, one could witness the devastation that shook the US on September 11, 2001. The entire world converges on the study table at the click of the mouse.

BBC and CNN are not just national news channels; they have become international news channels. McDonald's is no more an American concept. Mumbai kids relish the happy meal and free toys as much! Boundaries have disappeared, borders have merged, channels are open. Global is obsolete, glocal is in. It's the era of technological revolution. Communication has changed the world's perspective.

But ponder before the euphoria overpowers your rationality. The concept of globalization operates on near ideal conditions. These conditions rest on one major condition; the whole world has access to this technology. And there lies the catch. Sitting in your Los Angeles office, you cannot even imagine the gravity of starvation and epidemic in so many Afro-Asian countries. When even basic needs are not met, who cares about the Internet or satellite revolution?

Both aforementioned situations are exact contradictions. The question therefore arises whether the concept of global village is a myth or reality.

Industrialization initiated the trend and technical evolution catalysed it. The World Wide Web was the icing on the cake. But the actual origin of this concept can be attributed to the discovery of the earth being a circle rather than a square.



In fact, the spherical connotation wards off all the edges! The satellite pictures of the earth also show it as a unified area with patches of green and blue lending a symphony to its being. Even geography justifies the idea of ‘global village’!

The term ‘global village’ was coined by P. Wyndham Lewis in his book *America and Cosmic Man*. It was also written about by Marshall McLuhan in his book *The Gutenberg Galaxy*. Both the authors discuss the global outlook of the world as a whole. In fact, McLuhan emphasizes how time and space barriers have been eradicated by the technological boom. *Understanding Media*, McLuhan’s take on the concept of ‘global world’ builds the edifice on the foundation of electronic interdependence.

However, the concept of communication in terms of theory of cognitive dissonance raises some pertinent points. Our comprehension of any situation depends upon our perspective on issues, which in turn is moulded by our background, education and scores of other factors that might vary according to our cultural ethos and social conditions. The concept of ‘global village’ reflects the world as ‘one tribe’ ruling out individualistic interests. But cognitive dissonance breaks the myth of a unified world, where self-interests take over a global cause. The reason is simple. President Bush’s concerns directly confronted Saddam Hussein’s designs. Or for that matter, North Korea or Iran, accused by America for nuclear proliferation, justify their stand on the pretext of national security. The debate here is not about who is right or wrong, but what shapes extreme opinions on the same issue.

Multinational corporations are seen as agents of globalization in the developing countries. Critics however accuse the MNCs of economic imperialism. These are two facets of the same situation. The concept of global village, which seems so optimistic and real at a certain time, looks dingy, unreal and promoted by self-interests at some other times.

‘Perhaps we are laying the foundations of the global village and eventually everybody may be connected through an inclusive web. However, if we were all connected and aware of our interdependence it would not mean that we could all instantly get to know each other and solve our problems. We have trouble enough living together harmoniously in cities. As humans there is a sense that we can only know a limited number of people well - in *The Human Animal*, Desmond Morris suggests the number as around 150 - and so although our personal tribe of friends may be spread across the globe, how can we possibly feel a strong sense of community with all the millions of us on this earth? Besides, can we have as intimate a relationship with people through a telephone line?’ (Benjamin Synes in his essay *Marshall McLuhan’s Global Village*).

Technology would keep developing, boundaries would keep dissolving and barriers would keep breaking. The real barriers, however, are at the psychological level, and psyche cannot change overnight but is moulded by experiences. Certain experiences have to happen on a mass scale. Empathy needs to be imbued. All

## NOTES

## NOTES

this seems practical, but at a metaphysical level. What is metaphysical is not mundane. What is not mundane, is probably impractical. What is impractical must be a myth. But technology is here in full swing, and that too doing its bit to bind and bring the world close. The concept of global village then seems a reality!

### **Global Village and Global Culture**

Communication technology has increased global connectivity. Consequently, there is huge cultural diffusion and mixing.

Let us understand this by means of an example. The brand 'Coke' (the famous beverage company) had a humble beginning in the year 1894 and started as a fountain beverage 'Coca-Cola' in the US. Nearly 400 Coca-Cola bottling plants were in operation by the year 1909. These plants were mostly family-owned businesses. The typical contour bottle representative of 'Coke' emerged in 1916. However, the 1920s and the 1930s saw the era of international expansion of the company. In the 1970s and the 1980s, the independent retailers who sold Coca-Cola merged into an international megachain. In the 1990s, post the fall of the erstwhile USSR and other major economic changes around the world, newer markets that were closed opened up. For these customers, the approach was different. The Coca-Cola bottling system grew in these countries with its base dug deep in the local communities. Coca-Cola has honoured local identity and retained the flavour of local markets. Over the years, due to Coca-Cola's superb advertising, Coca-Cola became a very well-known and popular brand throughout the world. Some of its advertisements became legendary. One such campaign was the 1971 'I'd like to buy the world a Coke' television spot, in which a crowd of children sang the song from atop a hill in Italy. Recently Coca-Cola's strategy has been to focus on emerging markets like China, India and Indonesia. All these have contributed to Coca-Cola becoming one of the best brands in the world. 'Coca Cola's success results from skilful balancing of global standardization and brand building with local adaption. For years, the company has adhered to the mantra 'Think globally, act locally.' (Kotler Armstrong, Principles of Marketing, Tenth Edition).

Another example that can substantiate the concept of the diffusion of global culture is television shows. Leading media company Viacom which owns MTV developed a smart localized strategy in Asia including South Korea, China, and Japan. The MTV strategy for entry into foreign markets was based on the policy that localized programming and localized business mode were more successful rather than following a standardization or unification strategy. In the Asian context, the plurality of languages, dialects and cultures is a crucial issue in programme distribution and consumption. This is a direct reflection of its importance in relation to its national and other cultural identities. India presents itself as a vibrant example in this context. India had just four television channels in 1990 and is going to cross the 500 mark by the end of this year. This is a good example of media globalization. International satellite services were first introduced via cable to the home in India

nearly two decades ago. This started an era of profusion of private channels in a society that had previously only known a government-controlled national broadcasting network, Doordarshan. Doordarshan had earlier been a boring, non-glamorous channel that showed a lack of innovation and creativity in its programmes. In the 1980s, there was a small change on Doordarshan as it started including entertainment programmes like those based on films or regular soaps. The actual big change occurred in 1992 after the liberalization of the Indian economy. Transnational partners entered the field and Star TV and other such channels were started. While the early stint of Star TV wasn't very successful, a revamp in the pitching and targeting led to great success. Once the channel understood the cultural connotations of the Indian society and modified its programming subsequently, there was no looking back for the Star TV network. This one step of modifying global ideas with local content has ensured the success of the overall television scenario in India.

## **NOTES**

### **Mass Media as Cultural Reflectors**

Mass media are involved in our lives institutionally, economically, socially, culturally and historically. The urge to communicate is a primary one. Communication is the art of transmitting ideas, information and attitudes to another person. Contemporary society however is far too complex to communicate only by means of face-to-face and direct contact. Delivering ideas, information, and attitudes to a large diversified audience can be achieved only through the mass media.

Mass media are defined as the technological means of transmitting ideas, opinions and information, through a mass communication device to a large and diversified audience. Mass media are cultural reflectors of the society. Different media genres like films, TV and music, reflect different cultural identities.

Mass media reflect the social world around them. We conventionally organize media according to how closely they represent reality. It is important to understand that media images are representations of the social and cultural world. No representation of reality will be totally true or real since the media will attach its own perceptions and frames of reference to it. Similarly, the audience's perception will also influence the representation. These media representations also draw inspiration from their socio-cultural environment and therefore reflect the culture of an era.

Mass media function as cultural reflectors in different ways. Let us look at few examples of different mass media and the cultural representations conveyed by them.

### **News Media as Cultural Reflectors**

The news media, print or electronic, represent happenings in the world as fairly and accurately as possible. Newspapers have played a vital role in our country's cultural life from the time of the British rule to the present. Before independence,

## NOTES

the press existed and was a powerful instrument for our freedom fighters even though the circulation was limited and the technology very primitive.

The first newspapers designed entirely for the common man was during the 1830s in America. This was called the era of the 'penny press'. Between 1880 and 1900, the role of the newspapers in America changed radically. Prior to this period, the newspapers did not have a direct influence on public opinion.

With the advent of massive urbanization in India, the daily press garnered a vast readership. This led significantly to a new kind of reader, with changing demographics and psychographics. The emergence of supplements with the daily copy of the main newspaper catered very well to this new reader. For example, most mainstream newspapers carry at least one supplement with the main newspaper on almost every day of the week. These supplements cover different popular areas like – guidance for higher education, career counselling, job opportunities, emerging businesses, lifestyle and health. Contemporary newspapers, therefore, are reflective of the popular culture trends of their readers.

The rise of television news channels has influenced the images of cultural representations. The 24x7 nature of television news channels has increased the demand for content manifold. Subsequently, news is no longer restricted to the domain of hard and serious news. TV news channels cover and showcase everything under the sun from politics to economics, from crime to gossip, and from human interest to lifestyle. The images they represent in this process are driven by both the need to appeal to their audiences as well as the advertisers. Hence, the content on television news channels is reflective of popular social and cultural trends. For example, looking at the cultural signs that are being circulated by the news may be a useful tool in charting the social construction of cultural understanding within a society. Infotainment in the form of celebrity gossip and many lifestyle news stories is the cultural reflector of what is more popular among the present urban audiences.

### **Non-news Media as Cultural Reflectors**

Non-news media including books (fiction and non-fiction), magazines and television programmes also represent cultural dynamics of a society. For instance, in a country like India which had only one television channel in the form of Doordarshan for a long time, the advent of more than 500 television channels has brought in a paradigm shift in the representation of cultural norms and images.

For example the content of Indian television soaps has evolved. The number of households with satellite connections have increased from 25 million homes to 90 million homes in the first decade of the 21st century. This included a new mass audience from smaller towns and cities. The soaps produced by Ekta Kapoor, a leading Indian producer dominated the Indian television for this decade. The story in most of these soaps was based in a rich urban family where the main female character is straightforward surrounded by scheming relatives and confronted with dramatic situations. This trend was used very successfully in serials of the decade.

By the end of the decade, the audience profile had changed and the new audiences could not relate to these themes. New trends came forth. Rural India and problems associated with the real India came forward. Television serials today represent this theme which has become a dominant culture on Indian television.

### **Films as Cultural Reflectors**

Cinema is a strong reflection of the culture of an era. For instance, the earliest Indian films were rooted in history and mythology as these were key cultural resources of that generation. After India gained independence, the spirit of hard work and development swept the nation. This got reflected in the films of that era which had such themes. The 1970s saw a multitude of films with strong social messages like importance of education and family planning. This was because the country was face with an onslaught of such social problems. Hunger and poverty were also rampant. Hence a series of mainstream films took these themes as their central idea. This era saw the emergence of the hero as a youth rebel who voiced the concern of the underdog with a strong and violent streak. It was an expression of the nation's youth culture of those times. With liberalization in the 1990s, there was a strong focus on wooing NRI audiences and therefore joint family melodramas catering to this audience became the popular theme of big-budget films.

Recently with the rise of multiplexes and the creation of a strong English-speaking urban audience, the content and style of films has undergone a transformation. Shorter films with never-tried-before themes are changing the landscape of Indian cinema.

### **New Media as Cultural Reflectors**

The Internet boom has changed the way we engage with the media. It has not only made this engagement very interactive but has managed to create a strong sub-culture in terms of creating institutions at the level of an individual. With the breakdown of the joint family system, as well as a massive influx of people to metro and mini-metro towns and cities, social isolation is the new socio-cultural trend. In such a scenario, engagement with new media has become a strong expression of this culture. The success of social networking sites like Facebook proves that the cultural framework of the society has been altered in a big way.

#### **3.2.1 Media Literacy**

Media literacy enables us to go through and analyse the messages that inform, educate and entertain us. Media literacy involves the application of critical thinking skills on all media, ranging from online environments to product placement in films. A media literate person tends to ask relevant questions about what is there and observes what is not there. Such a person will question the motives, money, values and ownership of media productions, and be aware of how these factors influence content.

## **NOTES**

## NOTES

A media literate person will seek answers to the following questions in his approach to media:

- Who is the message intended for?
- Who wants to reach a particular audience and what is the purpose of doing so?
- Whose perspective is used to tell the story?
- Who are the people who can communicate the media content?
- What are the strategies used to convey the message?

Media literacy is the possession of the knowledge to sift media truth from media fiction. Take the movie *Forrest Gump*, for a simple example. The lead character at one point in the movie is seen shaking hands with US President J.F. Kennedy. So, what's the big deal, you may ask? The catch was that this movie was made in 1994, 29 years after the assassination of President Kennedy. Yet, the state-of-the-art special effects turned this piece of fiction to seemingly concrete reality. Of course, when the media takes trickery like this and uses it on a grander scale to a wider platform, the consequences can be bad. Thus, there is a need for each individual to be media literate.

Media literacy is on the rise in countries like Great Britain, Australia, Canada, United States, Netherlands, Italy, Greece, Austria, Switzerland, India and Russia. Media studies has gained importance since the 20th century due to the extensive use of media and technology in education and because of cross-disciplinary work in these two domains. UNESCO has also supported media and information literacy by promoting the development of information and media literacy policies. It has promoted various training resources to help teachers use information and media literacy techniques in their teaching. It has also provided them with suitable pedagogical methods and syllabi. Research in media literacy is getting importance because it forms the basis for media education.

Education for media literacy is based on an inquiry-based pedagogic model that encourages people to ask questions about the media content they have watched, heard or read about. Media literacy education enables people to critically analyse messages, offers opportunities for learners to widen their media experience and helps them to develop creative skills so that they become competent enough to make their own messages.

The scope of critical analysis in media literacy includes identifying, examining and exploring the following:

- Author, purpose and point of view
- Construction techniques and genres
- Different patterns of media presentation and propaganda, censorship and bias in news and public affairs programming

Media literacy has made mass media, digital media and popular culture known to people as new types of media that require analysis and evaluation. Media literacy has changed the passive nature of media consumption into an active and critical process where misrepresentation and manipulation of information can be easily detected. This is because media literacy makes people become more aware and enables them to understand the role of mass media and participatory media in constructing reality. The negative aspects of mass media, such as violence, gender and racial stereotypes, projecting sexual nature and issues relating to loss of privacy and cyber bullying, can be countered by imparting knowledge in media and technology. Media literacy provides protection, especially to children and youth, by helping in making suitable and appropriate media choices in terms of consumption and patterns of usage.

In the 21st century, there is increased emphasis on the twin social responsibilities of communication and problem-solving skills. More than 600 educators form the National Association for Media Literacy Education (NAMLE), a national membership group that hosts a bi-annual conference. In 2009, this group developed a policy document, *The Core of Media Literacy Education in the United States*. This document states that the purpose of media literacy is to help individuals of all age groups develop and nurture the habit of questioning; they should be critical thinkers, effective communicators and hence active citizens in the contemporary world. They should be identified as aware people who cannot be misled by any kind of manipulated information coming through any source. This document also laid down certain principles of media literacy.

- Media literacy education requires active participation in terms of questioning and critical thinking.
- Media literacy expands the concept of all forms of media and helps people to understand them in an analytical manner.
- Media literacy education builds and generates skills in learners through integrated, interactive and repeated practices.
- Media literacy education leads to the development of well-informed, interactive, aware and engaged citizens. This boosts the image of a democratic society.
- Media literacy makes individuals realize that the importance of media as an important agent of socialization.
- Media literacy education confirms that people should use their skills, beliefs and intelligence to create and perceive their own meanings and perceptions from the media messages that they receive.

The media industry has undoubtedly played a very important role in extending its support to media literacy education so that the individuals are able to assess the role of media in the society and the world.

## NOTES

## NOTES

### 3.2.2 Internet and Society

In practice, the Internet connotes a global system of interconnected computer networks using the standard Internet Protocol Suite (TCP/IP) to provide services to billions of worldwide users. It is a ‘network of networks’ consisting of millions of public, private, academic, business and government networks, ranging from local to global in scope, that are linked by a wide array of electronic, wireless and optical networking technologies. The Internet carries a huge range of information services and resources such as ‘the inter-linked hypertext documents of the World Wide Web (WWW) and the infrastructure to support electronic mail’.

Conceived as a fool-proof network which could connect computers and be resistant to any one point of failure, the Internet cannot be completely disposed off by one particular event or happening. Still if big areas get disabled, the information can be easily rerouted. Although the Internet itself came to existence in 1969, it truly became a global network after the British scientist Tim Berners Lee invented the World Wide Web in 1989 and implemented it in 1991. Presently, the Internet has turned out to be the eventual platform for accelerating the flow of information and is, currently, the fastest-growing kind of media and is turning various other forms of media outdated.

#### How the Internet works

Although the Internet is still a young technology, it is not easy to imagine life without it now. With each passing year, technical minds the world over create more devices to integrate with the Internet and their number is rapidly increasing with each passing day. This network of networks is crisscrossing the globe and is even extending into space. The pertinent question is, ‘What makes it work?’

To analyse the Internet, it is helpful to look at it as a system having two main components. The first component is **hardware**. It includes everything from the cables that carry terabits of information every second to the computer. The other types of hardware which support the Internet comprise routers, servers, cell phone towers, satellites, radios, smartphones, etc. These devices combine together to form the network of networks. The Internet is a very accommodating system, i.e., it changes in little ways as elements join and leave networks around the world. A few of those elements might remain fairly static and form the backbone of the Internet, while others are more peripheral in nature.

These elements are connections. Some of them are end points—the computer, smartphone or other device you are using to read this might count as one. Those end points are called **clients**. Servers are the machines that store the information we seek on the Internet. Other elements comprise the **nodes** serving as a connecting point along a traffic route. Further, there are the transmission lines that can be physical, as in the case of cables and fiber optics, or they may be useless signals from cell phone, satellites, 4G towers or radios.



All this hardware cannot generate a network without the second component of the Internet: the protocols. **Protocols** are the sets of rules followed by the machines to complete the tasks. In the absence of a common set of protocols that all machines connected to the Internet have to follow, communication between devices cannot take place. The various types of machines would be unable to understand one another or even send information in a meaningful manner. The protocols provide both the method and a common language for machines to use to transmit data.

### **Impact of the Internet**

Because of its extensive usability and access, the Internet has enabled completely new forms of interaction and activities. Its main features are such as to allow its pervasive usability and access. Social networking websites like Facebook, Twitter, and Instagram have formulated new means to socialize and interact. The users of such sites can add a huge variety of information to pages, to follow common interests, and to connect with others. Also, it is possible to find existing acquaintances and then pursue communication among the existing groups of people. Sites such as LinkedIn promote commercial and business connections. YouTube and Flickr specialize in users' videos and photographs.

During the first decade of the 21st century, the new generation has the advantage of widespread availability of Internet connectivity. However, it has resulted in consequences and concerns in areas like personal privacy and identity, and distribution of copyrighted materials. These 'digital natives' face numerous challenges that were not available to the previous generations. Those belonging to the earlier generations, possibly the parents of digital natives who are now open to this new panorama of knowledge and adapt to the technology by acquiring computer skills, are called digital migrants. It is noteworthy that these digital migrants are also in considerable numbers.

The Internet has acquired a fresh relevance as a political tool, leading to Internet censorship in some countries. For **instance**, in 2016 the presidential campaign of Bernie Sanders was prominent for its success in soliciting donation via the Internet. Various political groups use the Internet to acquire a new method of organizing to carry out their mission, having given rise to Internet activism, most remarkably practiced by the rebels in the Arab Spring. A few governments like Iran, North Korea, Myanmar, the People's Republic of China and Saudi Arabia restricted what people in their respective countries can access on the Internet, particularly the content that is political and religious in nature. It is achieved through software which filters domains and content so that they might not be easily accessed or obtained without elaborate circumvention.

In countries like Norway, Denmark, Finland and Sweden, the key Internet service providers have willingly, probably to avoid such an arrangement being turned into law, agreed to control the access to sites listed by authorities. While

## **NOTES**

## NOTES

such a list of restricted URLs is only supposed to contain addresses of the known child pornography sites, the list is still secretive. Various countries, including the United States, have formulated laws against the possession or distribution of certain material, such as child pornography, via the Internet, but do not mandate filtering software. There are various free and commercially available software programmes, known as content-control software, with the help of which a user can opt to block offensive websites on individual computers or networks. It helps to limit a child's access to pornographic materials or depiction of violence.

The Internet has been a key outlet for leisure activity since its inauguration. Presently, various Internet forums contain sections devoted to games and funny videos. Further, short cartoons in the form of Flash movies are also popular these days. More than 6 million people use blogs or message boards as the means of communication as well as for the sharing of ideas and opinions. Gambling and pornography industries have taken advantage of the World Wide Web and usually provide a considerable source of advertising revenue for other websites. Even though various governments have tried to control both industries' use of the Internet, it has usually failed to stop their extensive popularity.

Multiplayer gaming is one key domain of leisure activity on the Internet. This kind of recreation forms communities, where people of all ages and origins entertain and enjoy the fast-paced world of multiplayer games. These vary from first-person shooters and role-playing video games to online gambling. A number of people use the Internet to access and download music, movies and other works for their relaxation and enjoyment. There are free and fee-based services for such activities, using centralized servers and distributed peer-to-peer technologies. Some of these sources take more care with respect to the original artists' copyrights in comparison to others.

A number of people use the World Wide Web to have an access to news, weather and sports reports, to plan and book vacations and to know more about their interests and hobbies. Individuals use chat, messaging and email to stay in touch with friends across the world, sometimes in the same manner as some previously had pen pals. The Internet has witnessed an increasing number of Web desktops, where the users may access their files and settings through the Internet.

### 3.2.3 Impact of Media on Politics

The media is a platform through which communication is passed from one individual to another, or from one place to another. The media stimulates citizen engagement in politics; these encompass political party's membership registration, voters registration, elections and electoral campaigns, electorates management, are among the major political activities.

The news media is a societal or political force or institution whose influence is not consistently or officially recognized. A free press serves four vital purposes:

- Holding government leaders accountable to the people.

- Publicizing issues that need attention.
- Educating citizens so they can make informed decisions, and
- Connecting people with each other in civil society.

Free media plays a critical role in influencing political discourse during elections. When free and balanced, print and broadcast media foster transparency and the determination of important electoral information. The rise of new media provides further opportunities for participatory citizenship.

Citizens are increasingly turning to social media platforms to follow election news and developments. Referred to as “The Fifth Estate,” this form of “news” media is a socio-cultural reference to groupings of outlier viewpoints in contemporary society, and is most associated with bloggers, journalists publishing in non-mainstream media outlets, and the social media.

The media has a remarkable effect on politics and the politicians themselves. It is within human nature to believe what is told to us. We tend to believe the media because research is done by them and they are a main source of information. The media, as a medium of communication, constitutes different forms like films, posters, social media, news channels, newspapers.

The media’s impact on politics can be both constructive as well as propagandist, depending on the motives involved. Some of the ways in which the media influences politics is discussed below:

- Coverage bias in favour of certain political parties
- Spreading of fake news or biased reports
- Adapting and promoting to the political ideas of certain political parties
- Proxy campaigning for the parties during elections
- Using social media to directly connect with the target audience and starting a predetermined campaign
- Using social media to organize people together for certain issues
- Constant fact-checking and analysis of political statements through data journalism to expose any political lies
- Using impactful original and doctored images/videos, like deep-fakes, etc. to promote an agenda
- Giving platform to certain political factions to help them voice their issues or polarize the audience
- Spotlighting specific issues to influence public opinion
- Highlighting particular political concerns to get attention of the policy-makers.
- Starting campaigns to empower civil societies
- Ensuring that political information is accessible to all

## NOTES

## NOTES

### 3.2.4 Media Education

The concept of media education and its relation to media literacy can be understood with the example of a house, where the house is media literacy and the bricks and mortar are media education. Media education can be defined as the process by which people become media literate and are able to critically understand the nature, techniques and impacts of media messages and productions.

In the modern world, there is a growing need to connect classroom learning with the real world and use media content in classroom study for analysis, evaluation and discovery.

Media education uses critical thinking skills to help decode, analyse, synthesize and evaluate traditional and digital media and popular culture texts, such as fashion and technology trends, literature and shopping patterns. It encourages a probing and questioning approach, such as:

- Who is the audience of a media production?
- Why has the particular audience been chosen?
- Whose perspective is used to tell a story?
- How do the elements and codes of a genre influence what is seen, heard or read?
- What and how might different audiences interpret a media production?

The growth and development of digital media has added to the list of challenging questions:

- How does technology influence how we relate to others?
- Has technology enriched or undermined culture, learning and community?
- What are the roles played by ownership, control and access?
- What are the challenges in regulating the Internet?

Media issues are often complex, contradictory and controversial, and the educator's role is not to 'impart' knowledge, but to facilitate inquiry and dialogue. The teacher's, or rather the instructor's, role is to act as a facilitator and co-learner in a student-centred learning process in media education.

In the modern world, the challenges are to identify and assess the right information and synthesize what one locates into useful knowledge or communication. Media education, combined with techniques of critical thinking, is a key part of the 21st century approach to learning.

#### NCERT and media education

A recent study conveyed by the National Council of Educational Research and Training (NCERT) on the usage and application of educational television (ETV) in schools under the direction and supervision of Delhi administration has shed light on an intriguing point.

- Television is provided to approximately 500 schools and only 38 per cent are using ETV in senior secondary classes where only sixteen lessons are held every week. The causes for this low utilization are as follows:
  - o Inept maintenance of television sets
  - o Unsatisfactory viewing conditions in classrooms
  - o Indifference on the part of teachers
  - o Lack of interest and enthusiasm among students, who are under constant pressure and are not too keen to learn more about and from new technology

A previous study by the NCERT of school broadcasts from the All India Radio (AIR) came up with even graver results. No genuine consideration has been shown towards these serious lacunae.

The need for media education extends to all individuals, irrespective of demographics—background, age, education or geographical location. With an increase in the need for media education, the problem of identifying the right media according to potential, reach and cost effectiveness has also gone up. But this grave issue has been reduced to a casual approach. Take for instance the condition of educational television in Delhi. The decision to provide such a facility was taken in 1961 to broadcast curriculum-based lessons on selected subjects, especially sciences, because at that time, a large number of schools in Delhi had no provision for laboratories, equipment or specialized teachers. The Delhi Television Centre was used to help teachers for this purpose. Although this programme has continued but there has not been any substantial progress in education or response from students and teachers.

The use of media for education purposes needs two special considerations: one is related to the management and the other is related to the selective use of management. Since education comes under the jurisdiction of the state government and broadcast media under the jurisdiction of the central government, problems regarding management and coordination exist. Therefore, there is an urgent need to allocate different arrangements at the regional and local level through an independent board comprising educationists, social scientists and media experts.

Broadcast media can be used in education to provide an enriching and enhancing learning experience to students. So when an educational broadcast programme is delinked from the school or college curriculum, it can be called a serious setback. Moreover, if we go by the past experiences of broadcasts programmes, there seems to be a lack of interest as well as hope for syllabus-based broadcasts in classroom teaching.

### 3.2.5 Business and Culture

Business organizations today operate in a global market place. Advancements in travel and communication sectors have facilitated access to broader, cross-country

## NOTES

## NOTES

markets. Organizations, both small and big, with operations spread across different cultures and different countries, operate and thrive in the world of business. Businesses not only establish countrywide operations, but also grow beyond and become multi-national corporations (MNCs) with global operations. Growth of businesses and operations across countries means people from one region and one country would have to interact and communicate with people across different countries. Multi-national companies employ people from different regions and place them anywhere in the world. These developments have resulted in adding cross-cultural dimensions to the subject of business communication.

### **Awareness of Cultural Differences**

Culture relates to the customs, ideas and values of a particular civilization, society or social group, especially at a particular time. Culture is what people are. It relates to the way of life and encompasses beliefs, attitudes, values, expectations and norms of behaviour. People from the same cultural background share common beliefs and values and their expressions, approaches, understanding and responses to given situations follow a certain predictable pattern. Given this commonality, communication within this cultural group is easy.

Differences in culture translate into differences in language, accent, background, body language, distance, intimacy, values, beliefs and expectations. These differences get sharper with distance and diversity. In a country like India, culture would vary from eastern region to western and southern region to northern region. In the larger context, there are huge cultural differences among people across the globe. Countries in the eastern region like Japan, Korea, China and India are culturally very different from western countries like England, Germany, USA and Canada. Religions and backgrounds further accentuate these cultural differences. Religions specify certain behaviour and discipline, which people subscribing to that religion adhere to. Arab countries follow Islam and their practices would vary very much from people following other religions like Hinduism, Buddhism or Christianity. All these diversities make the process of business communication more complex. It is pertinent to note here that there is a term called 'culture shock' that refers to disorientation caused by a change from a familiar environment, culture and ideology to another that is radically different or alien. Awareness and preparedness help overcome any kind of culture shock. A business communicator, to be effective, should recognize the diversity and make conscious efforts to adapt, orient and reach out.

Business communication is always goal oriented. Be it oral, written or even non-verbal communication, the communicator wants to convey the message so as to elicit the desired response. This may relate to providing information or seeking some specific response or even motivating people to act in a particular manner. Cultural differences call for adapting the appropriate tone, accent, loudness, pace and clarity in verbal communication, and appropriate handshake, postures, gestures,

body movements, timing and distance in non-verbal communication. It means that the approach to communication that works well within a cultural group need not necessarily work well in an inter-cultural context. Any business communicator who wishes to communicate effectively with heterogeneous cultural groups should make extra efforts to understand the cultural differences and accordingly develop relevant communication skills. Like it is in India, in other countries too, there could be region-to-region variations or rural–urban variations even within the country. Generalizations and presumptions, therefore, should be avoided.

### **Expert Speak: Intercultural Encounters**

Jeanette Martin of the University of Mississippi and Lillian Chaney of The University of Memphis in their paper on the subject of intercultural communication make the following noteworthy observations. "Successful interactions with people of other cultures involve knowledge of communication skills to avoid inadvertently offending them during intercultural encounters. These encounters are becoming more frequent with the increased globalization of the business and the multiethnic composition of the workforce. To compete successfully in the international arena, companies conducting business abroad should arm themselves with knowledge of the communication customs of people of other cultures. The communication skills that are highly visible during intercultural encounters include greetings, introductions, and business cards; conversational customs; dining and tipping; dress and appearance; and non-verbal communication. *A faux pas* during greetings and conversations can result in personal or professional embarrassment. Even using inappropriate table manners, wearing inappropriate attire, or using gestures with negative connotations may not only cause discomfort but may be sufficiently serious to lose a contract or to close the door to conducting business in the future." (Source: Proceedings of the 74th Annual Convention of the Association for Business Communication. November 4-7, 2009. Portsmouth, Virginia, USA)

Cultural differences across different regions and countries manifest themselves in different ways. The business communicator should be particularly conscious about the following aspects: conversational style, method of greeting, timing and punctuality, paying compliments, giving gifts, attire and dressing up for meetings, respect for elders, addressing people by name, interpretation of silence, spatial distance during meetings, gestures and touch, use of manners and formality, frankness and intimacy, expression of emotions and methods of negotiation.

### **Check Your Progress**

1. Who coined the term 'global village'?
2. What does our comprehension of any situation depend upon?
3. What does media literacy entail?
4. How is business communication always goal oriented?

## **NOTES**

---

### 3.3 ANSWERS TO CHECK YOUR PROGRESS QUESTIONS

---

#### NOTES

1. The term 'global village' was coined by P. Wyndham Lewis in his book *America and Cosmic Manoif*.
2. Our comprehension of any situation depends upon our perspective on issues, which in turn is moulded by our background, education and scores of other factors that might vary according to our cultural ethos and social conditions.
3. Media literacy involves the application of critical thinking skills on all media, ranging from online environments to product placement in films.
4. Business communication is always goal oriented. Be it oral, written or even non-verbal communication, the communicator wants to convey the message so as to elicit the desired response.

---

### 3.4 SUMMARY

---

- Communication is the process of making meaning. The study of communication suggests that through language and communication we define and shape our social and cultural world.
- Communication technology has increased global connectivity. Consequently, there is huge cultural diffusion and mixing.
- Mass media are involved in our lives institutionally, economically, socially, culturally and historically. The urge to communicate is a primary one. Communication is the art of transmitting ideas, information and attitudes to another person.
- Contemporary society however is far too complex to communicate only by means of face-to-face and direct contact. Delivering ideas, information, and attitudes to a large diversified audience can be achieved only through the mass media.
- The news media, print or electronic, represent happenings in the world as fairly and accurately as possible.
- Newspapers have played a vital role in our country's cultural life from the time of the British rule to the present.
- Media literacy involves the application of critical thinking skills on all media, ranging from online environments to product placement in films.
- The Internet connotes a global system of interconnected computer networks using the standard Internet Protocol Suite (TCP/IP) to provide services to billions of worldwide users.



- The Internet is a ‘network of networks’ consisting of millions of public, private, academic, business and government networks, ranging from local to global in scope, that are linked by a wide array of electronic, wireless and optical networking technologies.
- The media’s impact on politics can be both constructive as well as propagandist, depending on the motives involved.
- Media education can be defined as the process by which people become media literate and are able to critically understand the nature, techniques and impacts of media messages and productions.
- Media issues are often complex, contradictory and controversial, and the educator’s role is not to ‘impart’ knowledge, but to facilitate inquiry and dialogue.
- Business organizations today operate in a global market place. Advancements in travel and communication sectors have facilitated access to broader, cross-country markets.
- Differences in culture translate into differences in language, accent, background, body language, distance, intimacy, values, beliefs and expectations. These differences get sharper with distance and diversity.
- The business communicator should be particularly conscious about the following aspects: conversational style, method of greeting, timing and punctuality, paying compliments, giving gifts, attire and dressing up for meetings, respect for elders, addressing people by name, interpretation of silence, spatial distance during meetings, gestures and touch, use of manners and formality, frankness and intimacy, expression of emotions and methods of negotiation.

## NOTES

---

### 3.5 KEY WORDS

---

- **Hardware:** It includes everything from the cables that carry terabits of information every second to the computer.
- **Protocols:** In computing, a set of rules governing the exchange or transmission of data between devices.
- **Internet Protocol Suite:** It is the standard network model and communication protocol stack used on the Internet and on most other computer networks.
- **Cognitive Dissonance:** It is the state of having inconsistent thoughts, beliefs, or attitudes, especially as relating to behavioural decisions and attitude change.

---

### 3.6 SELF ASSESSMENT QUESTIONS AND EXERCISES

---

#### NOTES

#### Short-Answer Questions

1. How has communication technology led to cultural diffusion?
2. Define mass media.
3. How is news media a cultural reflector?
4. What is the relationship between media and education?

#### Long-Answer Questions

1. What is media literacy? Discuss its principles.
2. Describe how the Internet works.
3. What is the impact of media on politics?
4. Discuss the relationship between business and culture.

---

### 3.7 FURTHER READINGS

---

Schramm, Wilbur. 1966. *The Science of Human Communication*. Illinois: The Business Press.

Rosengren, Karl Erik. 2000. *Communication: An Introduction*. London: Sage Publication.

Fiske, John. 1988. *Introduction to Mass Communication*. London: Routledge.

Berger, Arthur Asa. 1997. *Essentials of Mass Communication Theory*. Thousand Oaks, CA: Sage Publications.

McQuail, Denis. 1983. *Mass Communication Theory*. London: Sage Publications.

Hanson, Jarice. 1994. *Connections: Technologies of Communication*. New York: Harper Collins Publishers.

William, Reymonds. 1994. *Invention of Communication*. New Delhi: Sage Publications.

---

## UNIT 4 COMMUNICATION PROCESS

---

### NOTES

#### Structure

- 4.0 Introduction
- 4.1 Objectives
- 4.2 The Human Communication Process
- 4.3 A Review of Some Basic Models and the Ingredients
- 4.4 Answers to Check Your Progress Questions
- 4.5 Summary
- 4.6 Key Words
- 4.7 Self Assessment Questions and Exercises
- 4.8 Further Readings

---

### 4.0 INTRODUCTION

---

As we have learnt, communication is a pervasive activity which encompasses almost all facets of our lives. Much of our life is spent communicating with each other, be it at our work place or in our family life. Various models and processes of communication have been developed by theorists and scientists. A few of the distinct characteristics of communication are as follows:

- Communication involves at least two persons—the sender and the receiver.
- It involves the transfer of ideas, facts, emotions, gestures, symbols and action from sender to receiver.
- Understanding is an essential component of communication, that is, the ideas, opinions, emotions, and so on, conveyed should be accurately replicated in the receivers' mind.
- Communication may be intentional or unintentional.
- The purpose of communication is to elicit action, inform or to express a certain point of view.

This unit will discuss the human communication process. It will also review some of the basic models of communication.

---

### 4.1 OBJECTIVES

---

After going through this unit, you will be able to:

- Examine the human communication process
- Briefly discuss the various models of communication

---

## 4.2 THE HUMAN COMMUNICATION PROCESS

---

### NOTES

The process of communication is implicit in the way in which a society functions. It is, in fact, integral to the existing and prevailing social norms which guide the everyday life of individuals living in society.

Communication is a process that involves a series of actions and a number of factors to transmit a message from one end to another. It would be good for you if you look for the examples of communication around and then work out various steps of this process. Let us think of normal conversations in which we engage every now and then. Think and analyse what happens when one is thirsty and wants a glass of water to quench the thirst. The person in question in this case is the sender of a message which is formulated in a language which the receiver of that message understands. If the language is English the message prepared could be a sentence such as 'give me a glass of water please!' This is sent through a medium and the communication is considered as complete if the receiver of the message gives a glass of water to the originator of the message. In this case the action of giving water would be the feedback.

Sometimes the act of communication becomes difficult as there are many people talking to each other and in spite of talking loudly, to the extent of shouting, may not reach the ears of the selected respondent. It is said that the noise in the channel has not allowed the communication to take place and as a result the receiver of the message has not reacted in the manner desired by the speaker.

The process of communication possesses certain dynamism and goes through various phases. This has been described below:

#### 1. The sender has an idea

It is indeed very difficult to think of a situation in which individuals are trying hard to communicate using common ground. This phase begins the moment the sender has an idea and decides to send a message to someone, intentionally.

#### 2. The sender encodes the idea

Human beings have learned the skills to transmit symbols as representations of their ideas and thoughts. Such symbols are varied in nature and content. People use a variety of symbols to convey their thoughts and ideas. Such symbols have evolved linguistically (verbal or written) to develop into sophisticated languages. There are many types of languages: the Braille language, the Morse code, the American Sign Language, and every other spoken and dead language in the world. Apart from this, there are other symbols that are used to communicate: paintings, pictographs, traffic signals, zip codes, mathematical formulas, hieroglyphs, baseball gestures conveying instructions from managers to players, etc.

The expression 'TREE' written on a blackboard is not a tree in reality. These are but the agreed representations of some reality. It is obviously the sender's responsibility to select a code best capable of carrying the message. While encoding one's idea, the individual should choose the code which will suit the message thus allowing the receiver to understand it completely. So we can say that the sender encodes the message.

## NOTES

### 3. The sender transmits the message

To suitably transmit the encoded message, the sender is required to select a channel or a medium to send the message. The information can be sent verbally or non-verbally by the sender. The messages are sent with the help of the tone of voice, gestures and the use of space in non-verbal communication. On the other hand, in verbal communication, messages are conveyed through speeches or documents. Hence the messages are sent through different media like telephones, computers, videocassettes, DVDs, CDs, papers, faxes, radios, etc. However, few channels are more suitable for some messages in comparison to others. For instance, a five-page memo is not a good choice for a lunch invitation. The particular characteristics of all the mediums somewhat decide their capability to serve a particular objective. Such characteristics explain the richness and suitability of a particular medium. A rich medium can:

- convey a message using more than one kind of clue (visual, verbal or vocal)
- facilitate feedback
- establish personal focus

Face-to-face conversation is the richest medium. Such conversations enable the receiver to receive the sender's message verbally (i.e., spoken words), non-verbally (i.e., gestures and the facial expressions) and vocally (i.e., voice tone or the pace of the speech). In face-to-face conversations, there is immediate feedback from the receiver. They also enable the sender to take control of few of the environmental noises as well. Such conversations can be personalized by the sender to all receivers concerned.

Apart from the richness, the chosen medium should be evaluated for other characteristics as well. The speed of the medium might be a criterion for its selection. For instance, the quickness of a message prepared on a particular medium (formal letter versus memo) or delivered (snail mail versus email) can be the criterion to opt for that medium. One of the criteria for a medium's choice is its ability to be permanently preserved. The reason to pick a particular medium is also dependent upon whether the record of a message can be kept on it or not (email versus 3M note). Other criteria of the medium comprise:

- feedback capacity (letter versus telephone conversation)

## NOTES

- ability to convey the intensity or the sophistication of a message (formal written report versus casual conversation)
- level of formality (formal letter versus email)
- level of confidentiality (fax versus sealed hand-delivered letter)

The sender should also choose the medium capable of efficiently and effectively conveying the message. While selecting a media, one should opt for the one capable of conveying the message appropriately to the target audience. Hence the sender transmits the message.

### 4. The receiver gets the message

Unless he/she is suffering from a hearing problem or he/she is distracted by noises distorting the receiving of the message, the receiver gets the signal sent by the sender.

### 5. The receiver decodes the message

The receiver decodes the message with the use of his/her knowledge of the code that has been used to encode the message. If the receiver has a poor knowledge of the language that is used, he/she is likely to decode the message inappropriately. Also, a receiver putting an effort to decode conflicting nonverbal and verbal messages is likely to incorrectly decode the intended message. The receiver selects the code he/she is going to use for decoding the message. Selecting the wrong code is similar to use a wrong key—the message may not open its secret if the wrong code is used. The receiver will select a code on the basis of his/her background and environment. The receiver possesses the accountability to choose the right code for decoding the message. Essentially, the receiver also has to listen to the sender. Hence the receiver decodes the message.

### 6. The receiver sends feedback to the sender

With the use of the same phases as the sender, the receiver sends a message back to the sender. It provides information on his/her level of understanding of the message. This message is called feedback. Feedback may be classified into two types: immediate feedback and delayed feedback. Immediate feedback is the type of feedback where learners do not have to wait to receive the feedback as they receive it immediately. However, areas where feedback generation requires deep assessment may take some time to be produced. This kind of feedback is termed as delayed feedback. This feedback can be used to improve performance in the future.

### Noises or barriers to communication process

All through the process of communication, unintended interferences take place. These distort or interrupt the process. Such interferences are known as 'noises'.

These may be real noises, i.e., auditory stimuli such as people talking, phones ringing or jack-hammering street workers. Other noises comprise distractions such as a stalker running across a stage. Noises create distortions as well. We are yet to come across communication without noises. Hence, finding out the sources of noise and making an effort to minimize its effect are necessary to improve the communication efficiency. Noise may be classified into four types: physical, psychological, physiological and semantic. Physical noise is the noise that is produced externally while the speaker and listener are trying to communicate. For example, a song being played in another room or the noise of construction in the neighbourhood is an example of physical noise. Psychological noise is the one that interferes with communication taking place between two people because one of them is not attentive to the communication, and is mentally absent. Any physiological problem such as headache or pain can make it difficult for a listener to concentrate on the communication. This is termed as physiological noise. Semantic noise takes place when there is no shared meaning in a communication. This may happen when the speaker is using a particular jargon or parlance that is not understandable by the layman listener.

## NOTES

---

### 4.3 A REVIEW OF SOME BASIC MODELS AND THE INGREDIENTS

---

We have already discussed the basic communication models and their ingredients in Unit 2. Let us revisit some of the concepts discussed there in brief.

#### **Aristotle Model**

According to the Aristotle model, the speaker plays a vital role in communication. According to the model, the speaker communicates in such a way that the listeners get influenced and respond accordingly. This model is the most widely accepted and the most common model of communication where the sender sends the information or a message to the receivers to influence them and make them respond and act accordingly.

#### **Berlo's Model**

While the Aristotle model of communication puts the speaker in the central position and suggests that the speaker is the one who drives the entire communication, the Berlo's model of communication takes into account the emotional aspect of the message. Berlo's model of communication operates on the SMCR model.

#### **In the SMCR model**

- S - Stands for Source
- M -Message
- C -Channel
- R –Receiver

There are different issues in the Berlo's model of communication. According to this model, the speaker and the listener must be on a common ground for smooth conversion which is sometimes not practical in the real scenario.

## NOTES

### **Shannon and Weaver Model**

This model simply proposes that a message is initiated from the person who gets the thought or has the information. The sender is also called the Source of information or the Information Source. The information then gets transferred from the brain to the mouth and comes out as a signal which then reaches the recipient after joining hands with several noises and other disturbances. The recipient then further passes on the message to its final destination or other minds of other persons. The issue with this model is that the message while reaching the final destination might get distorted sometimes as individuals interpret messages in different ways.

### **Schramm's Model**

According to the Schramm's Model, coding and decoding are the two vital processes of an effective communication. He also stressed that the communication is incomplete unless and until the sender receives a feedback from the recipient. According to the Schramm Model of communication then, when a sender passes on the information to the receiver, the receiver must deduce it in the desired form the sender wants and give him the feedback or respond accordingly. In this model, any type of communication where the sender does not get the feedback, the communication is not complete and thus useless.

### **Helical Model of Communication**

According to the Helical Model of communication, the process of communication develops from the very birth of an individual and continues till the existing moment. This model comprehends communication in a broader perspective and considers almost all the activities of a person from day one to till date. It cumulates all the activities occurring in the complete span of an individual that affects the process of communication, which in turn goes forward and also depends on the past activities.

#### **Check Your Progress**

1. What is the process of communication?
2. What does the sender need to do to suitably transmit the encoded message?
3. What are the two vital processes of effective communication according to the Schramm model?
4. On what does Berlo's model of communication operate?



---

## 4.4 ANSWERS TO CHECK YOUR PROGRESS QUESTIONS

---

1. Communication is a process that involves a series of actions and a number of factors to transmit a message from one end to another.
2. To suitably transmit the encoded message, the sender is required to select a channel or a medium to send the message.
3. According to the Schramm's model, coding and decoding are the two vital processes of an effective communication.
4. Berlo's model of communication operates on the SMCR model.

## NOTES

---

## 4.5 SUMMARY

---

- Communication is a process that involves a series of actions and a number of factors to transmit a message from one end to another.
- Sometimes the act of communication becomes difficult as there are many people talking to each other and in spite of talking loudly, to the extent of shouting, may not reach the ears of the selected respondent.
- To suitably transmit the encoded message, the sender is required to select a channel or a medium to send the message. The information can be sent verbally or non-verbally by the sender.
- All through the process of communication, unintended interferences take place. These distort or interrupt the process. Such interferences are known as 'noises'.
- Noise may be classified into four types: physical, psychological, physiological and semantic.
- According to the Aristotle Model, the speaker communicates in such a way that the listeners get influenced and respond accordingly.
- The Shannon and Weaver Model simply proposes that a message is initiated from the person who gets the thought or has the information. The sender is also called the Source of information or the Information Source.
- According to the Schramm Model of communication then, when a sender passes on the information to the receiver, the receiver must deduce it in the desired form the sender wants and give him the feedback or respond accordingly.
- According to the Helical Model of communication, the process of communication develops from the very birth of an individual and continues till the existing moment.

NOTES

---

## 4.6 KEY WORDS

---

- **Feedback:** It refers to information about reactions to a product, a person's performance of a task, etc. which is used as a basis for improvement.
- **Coding:** It means to convert (the words of a message) into a code so as to convey a secret meaning.
- **Distortions:** Things that are twisted or altered out of its true, natural, or original state.

---

## 4.7 SELF ASSESSMENT QUESTIONS AND EXERCISES

---

### Short-Answer Questions

1. What are the four types of noise?
2. What is the Aristotle model of communication?

### Long-Answer Questions

1. Examine the process of communication.
2. What are the barriers to the communication process? Discuss.

---

## 4.8 FURTHER READINGS

---

- Schramm, Wilbur. 1966. *The Science of Human Communication*. Illinois: The Business Press.
- Rosengren, Karl Erik. 2000. *Communication: An Introduction*. London: Sage Publication.
- Fiske, John. 1988. *Introduction to Mass Communication*. London: Routledge.
- Berger, Arthur Asa. 1997. *Essentials of Mass Communication Theory*. Thousand Oaks, CA: Sage Publications.
- McQuail, Denis. 1983. *Mass Communication Theory*. London: Sage Publications.
- Hanson, Jarice. 1994. *Connections: Technologies of Communication*. New York: Harper Collins Publishers.
- William, Reymonds. 1994. *Invention of Communication*. New Delhi: Sage Publications.

---

**BLOCK - II**  
**JOURNALISM AND ITS ETHICS**

---

*Concept and Functions of  
Journalism*

---

**UNIT 5 CONCEPT AND  
FUNCTIONS OF  
JOURNALISM**

---

**NOTES**

**Structure**

- 5.0 Introduction
- 5.1 Objectives
- 5.2 The Concept of Journalism
  - 5.2.1 The Functions of the Press
- 5.3 Press Freedom
- 5.4 Responsibility of the Press
  - 5.4.1 Theories of Press
- 5.5 Answers to Check Your Progress Questions
- 5.6 Summary
- 5.7 Key Words
- 5.8 Self Assessment Questions and Exercises
- 5.9 Further Readings

---

**5.0 INTRODUCTION**

---

In the previous unit you studied the process of communication and its various models. The current unit is meant to enable you to understand the meaning, nature, scope and purpose of journalism. Journalism is a profession of disseminating news for information, education and entertainment. Mahatma Gandhi, for the same reason, described journalism as public service. However, with the growth and development of societies, it has become a sort of industry with significant power to manipulate the public opinion in order to muster power for itself or to support the political powers that be. It has also become an industry that can generate enough employment as well as millions of rupees as profits.

The purpose of this unit is to make you aware of the concept and functions of journalism. The unit will also discuss press freedom as well as the theories of the press.

---

**5.1 OBJECTIVES**

---

After going through this unit, you will be able to:

- Discuss the concept of journalism

- Explain the function of the press
- Describe the theories of the press
- Discuss what is meant by press freedom

## NOTES

---

### 5.2 THE CONCEPT OF JOURNALISM

---

Journalism is reporting of daily events. In modern times, journalism is seen as the profession of gathering news and information, processing it and finally disseminating it through a particular media. The news and information so gathered is required to be relevant to the society. It is for this reason that journalism, popularly known as the press, has been defined as an institution of mass communication essentially devoted to public service. It started as a small private trade and later become an industry, but it has now sufficiently grown and has acquired gigantic proportion of corporate business which in some places has also become a multinational corporation.

Journalism has been described in the *Encyclopaedia Britannica* in the following words:

Journalism includes the writing and editing of newspapers and periodicals. Although this is the basic definition of various tasks and processes intimately connected with the production of serial publication are commonly classified as journalistic. Thus, the gathering and transmission of news, business management of journals and advertising in all its phases are often thought of as coming within the field of journalism and the following the advent of radio and television, there was a trend toward including all communication dealing with current affairs in the term.

On the other hand, the New Webster's Dictionary gives a crispier meaning of journalism: '(Journalism is) the occupation of conducting a news medium, including publishing, editing, writing or broadcasting.'

Denis McQuail states that journalism is 'paid writing (and the audiovisual equivalent) for public media with reference to actual and ongoing events of public relevance'.

Many more meanings and definition can be found in various books, dictionaries and encyclopaedia, but it would be enough to understand that journalism is an activity that involves the gathering of news and information, and processing them by contextualising them for the society where they have to be disseminated and distributed. The dissemination is actually done by replicating the said news and information with the help of one medium or the other, i.e., print, radio, television, Internet, etc.

#### Origin and Nature of Journalism

Journalism is as old an activity as the primitive human societies. It has been a common human tendency to share new things with the fellow beings. In interpersonal

communication we normally ask questions like ‘What is the news?’ which refer to another similar questions like ‘What is happening?’ These questions are not referring to the news as we understand it now. Some people in India say that the mythical characters like Narad Muni and Sanjay were the earliest reporters, but the fact is that these were the people who were involved in simple interpersonal communication.

The press or journalism has been seen as an important institution of society as the larger societies need to disseminate news and information for maintaining the status quo or changing the social order if the need be. The transition from feudal society to bourgeois democratic society could not have been possible without the printing press, which initially allowed the publication of books that became the instruments of advocacy of various ideologies. We may recall the great debate between the French thinkers Descartes and Pascal. The philosophical vision of Descartes served as the basis of bourgeois revolution in France. The printing press was later used for practicing journalism and was given the status of fourth estate of democracy as it had to strengthen the gains of democracy and to prevent the return of feudal system. However, when democracy became the established order of governance, the freedom of press was used by various types of interests to gain the control of the society.

During the 18th century, British newspapers started with names ‘diurnals’. In due course of time, it began to be pronounced as ‘journals’. The *Dutas* or the messengers also worked as journalists starting from the 6th century BCE. In India, the *Dharma Mahamatras*, appointed by King Ashok, also worked as journalists during the period.

The history of printing is traced back to 868 AD when Chinese used the movable types for printing. However, Johann Guttenberg has the credit of developing movable metal type and the ink suitable for them in 1456. Twenty years later the first printing press of England was set up in Westminster. Printing press was introduced in India as late as 1556 and it took us more than two centuries to get the first newspaper rolling out. There are different versions regarding the earliest newspaper in the world. Some say that the first newspaper was started by an American, John Campbell in 1704. There are others who consider *Relation aller Furnemmen und gedenckwürdigen Historien* as the first newspaper. This newspaper in German language was published in Strasbourg from 1605 onwards. According to the *Encyclopaedia Britannica*, the first newspaper in the world is *Avisa Relacion Oder Zeitung*, published in 1609 in Germany.

In modern times, journalism has become a central activity of any society. It is required to maintain the social, political and economical order; it is required by individuals in the society for all kind of information that are required in life to survive in the mass society. Journalism and media have acquired the status of industry and become a major source of employment at various levels. Journalism has evolved into many forms to keep pace with the changing interests of people and the newly found segmented audiences. It is also true that with every new

## NOTES

innovation and invention in the area of media technologies, journalism has also changed itself to suit the new environment. It is for this reason that one can say that journalism as an activity will always remain relevant.

## **NOTES**

### **5.2.1 The Functions of the Press**

Apart from disseminating news and information in society in public interest, the press is also seen as a bridge between the government and the people, in the sense that it communicates the policy and programmes of the government to the people. At the same time, it conveys the grievances and perception of public about issues of the society to the powers that be.

As the ownership of the institutions of journalism is in the hand of people with a certain amount of capital to invest in this industry, there is always a possibility of using it for the benefit of the interests of certain individuals. In modern societies we find linkages between the economically stronger groups and the political parties. Hence, the press also functions as a means of influencing the political system by various kinds of interest groups. The exposure of the corruption in the distribution of 2G spectrums in our country in 2011 clearly showed the nexus between the top political leadership, managers of big corporate houses and the journalists trying to work for the benefit of different big players in the area of telecommunication. The investigations and publication of the tapes of discussions of Nira Radia with some prominent journalists of the Indian media had also exposed this nexus which presented an unfortunate picture of journalism playing the role of lobbying for vested economic interests.

The political system uses the press for dissemination of news and information for its own perpetuation. Besides, the role of the press is one of maintaining the status quo as every morning the newspaper by and large make us feel that things are all right in the world in general and in the country in particular. Even on the days where we get one or more shocking news, we are by and large assured that rest is all right. This could be called the assurances function of the press. The example given above also shows that the political system uses the media and the lobbyists to negotiate with each other for the formation of government as well as for reducing the conflicts that could lead to the destabilization of the political power.

Journalism as the fourth pillar of democracy has been granted the freedom of speech and expression in almost all constitutions world over. The press has to function as the watchdog of democracy by constantly being vigilant towards the functioning of the other three pillars, i.e., legislature, executive and judiciary. All governments in democratic systems try to use journalism for the propagation of their views. In some countries the government owns various media to do so, but the presence of free press in democracies has always kept these governments on their toes by constantly investigating and exposing their misdeeds or anti-people policies.

The press also has a duty and function of being vigilant to the political, economical and social processes. The watchdog function of press is one among the oldest main beliefs in journalism which maintains that the media is supposed to serve as a controller of government. Hence press was also called the watchdog. The concept of the 'watchdog' function of the press was propounded by the social theorist James Mill (1773–1836). He supported the freedom of press since it 'made known the conduct of the individuals who have chosen to wield the powers of government'.

In his 17th century pronouncement, Edmund Burke in England stated that the press had acquired the role of the Third Estate in Parliament, i.e., the press was playing the role of a watchdog over government. However, the concept was directly promulgated in the 18th century *Cato's Letters*, a series of letters in England. It advocated a free press and was comprehensively reprinted in the colonies. It spread the American idea of the press being the Fourth Estate, i.e., a watchdog of the government.

#### Check Your Progress

1. What is considered the earliest newspaper in the world?
2. Why does the political system use journalism?

### 5.3 PRESS FREEDOM

Press freedom is a logical extension of man's undeniable freedom of expression. At present, press freedom is a universal phenomenon, in spite of the ideological differences in several socio-political systems worldwide. This freedom is globally and ideally guaranteed by Article 19 of the Universal Declaration of Human Rights. It is preserved in the Constitution of almost all the countries in the world and customarily observed by societies.

#### Constitutional Status of the Media

Though freedom of press is a much talked about concept, interestingly, it is not mentioned as such in the Indian Constitution. It is understood to be covered under the provisions of Article 19 and derives its rights from the freedom of speech and expression, available to the citizens of India. Thus, the media has the same rights—no more no less than any individual to write, publish, circulate or broadcast. In a case relating to journalism in pre-independent India, the Privy Council held:

'The freedom of the journalist is an ordinary part of the freedom of the subject and to whatever length the subject in general may go, so also may the journalist, but, apart from statute law, his privilege is no other and no higher...No privilege attaches to his position.'

#### NOTES

## NOTES

The framework for analysing media rights remains much the same in post-independence India. In the case of *M.S.M. Sharma vs. Krishna Sinha*, the Supreme Court observed:

‘...being only a right flowing from the freedom of speech and expression, the freedom of the press does not stand on a higher footing than the freedom of speech and expression enjoyed by a citizen and that no privilege attaches to the press as such, that is to say, as distinct from the freedom of speech and expression of a citizen.’

In other words, the media enjoys no special immunity or elevated status compared to an Indian citizen and is subject to the general laws of the Constitution.

Contrary to the Indian Constitution, the First Amendment to the Constitution of the United States of America makes a specific reference to the freedom of press. Further, while the restrictions on the right to freedom of speech and expression are expressly spelt out in Article 19(2) of the Indian Constitution, this is not so under the First Amendment. The Supreme Court of the United States has read into the rights of the press certain implicit restrictions which are, in principle, no different from Article 19(2). However, generally, from a judicial and societal standpoint, the freedom of press in the US is far more robust than it is in India.

Although no special provision was made to safeguard the rights of the press in India, the courts have time and again confirmed that the rights of the press are implicit in the guarantee of freedom of speech and expression. Successive judgments of the Supreme Court of India have struck down laws that abridge the freedom of the press and have echoed the sentiment expressed in the first amendment.

Let us take a look at some of the landmark cases in this context:

### **Romesh Thapar vs. State of Madras**

This was one of the earliest cases decided by the Supreme Court. It involved a challenge against an order issued by the government of Madras under the Madras Maintenance of Public Order Act, 1949. It imposed a ban on the entry and circulation of the journal, *Cross Roads*, printed and published by the petitioner. The Court favoured the petitioner holding that the right to freedom of speech and expression was paramount and that nothing short of a danger to the foundations of the state or a threat to its overthrow could justify a curtailment of the freedom of speech and expression. (For more details, refer to the Appendix.)

### **Brij Bhushan vs. State of Delhi**

In this case, the Supreme Court quashed a pre-censorship order passed against the publishers of the *Organizer*. The order was passed by the authorities under section 7(i)(c) of the East Punjab Safety Act, 1949. The Court held that a restriction based on this section, which related to public safety or maintenance of public order, did not fall under the purview of Article 19(2). (For more details, refer to the Appendix.)



## Indian Express vs. Union of India

The case arose out of a challenge to the Working Journalists and Other Newspaper Employees (Conditions of Service) and Miscellaneous Provisions Act, 1955, on the ground that its provisions violated Article 19(1)(a). The Supreme Court held that the impact of the legislation on the freedom of speech was much too remote and no judicial interference was warranted. However, the Court recognized that laws which single out the press for laying excessive and prohibitive burdens upon it would be struck down as unconstitutional. This includes any burden which would restrict the circulation, impede access to all sources of information or restrict freedom of publication.

## NOTES

### Exhibit 5.1

The Press Freedom Index is published annually by Reporters Without Borders. According to their survey, India figured 138th among 180 countries in 2018. This was a marked deterioration from the 118th place in 2008. The index is prepared on the basis of questionnaires filled by journalists and media experts from across the globe.

## Freedom of Speech and Expression under Article 19(1)(a)

Article 19(1)(a) covers the right to express oneself by word of mouth, writing, printing, picture, or in any manner. It includes the freedom of communication and the right to propagate or publish one's views. The communication of ideas may be through any medium—newspaper, magazine, movie, electronic media or audio-visual media. Freedom of speech and expression includes the following rights:

### (i) Right to circulate

The right to free speech and expression includes the right not only to publish but also to circulate information and opinion. Without this, the right to free speech and expression would carry little meaning. In case of *Sakal Papers vs. Union of India*, the Supreme Court held that the State could not make laws which directly affected the circulation of a newspaper. This right extends not only to the matter which the citizens are entitled to circulate but also to the volume of circulation. This case arose out of a challenge to the newsprint policy of the government, which restricted the number of pages a newspaper was entitled to print. (For more details on the case, refer to Appendix 2.)

In another case, *Bennett Coleman & Co. vs. Union of India*, the Supreme Court held that newspapers should be left free to determine their pages and circulation. This case arose out of a constitutional challenge to the Newspaper (Price and Page) Act, 1956, which empowered the government to regulate the allocation of space for advertisements. The Court held that any restriction leading to a loss of revenue would affect the circulation, and thereby impinge on the freedom of speech.

## NOTES

### (ii) Right to criticize

Right to free speech includes the right to criticize the government, which is necessary for a healthy democracy. Decisions of the Supreme Court in later cases made it clear that criticism of the government was not to be regarded as a ground for restricting the freedom of speech or expression.

In *Anand Chintamani vs. State of Maharashtra* case, a full bench of the Bombay High Court upheld the right to criticize, in respect of *Me Nathuram Godse Boltoy*, a play critical of Mahatma Gandhi. The Court held:

‘...Respect for and tolerance of a diversity of viewpoints is what ultimately sustains a democratic society and government. The right of a playwright, of the artist, writer and of the poet will be reduced to husk if the freedom to portray a message ...is to depend upon the popular perception of the acceptability of that message.’

### (iii) Right to receive information

The right to receive information was upheld by the Supreme Court in a series of judgments in varied contexts including:

- Right to information from advertisements enabling the citizens to get vital information about life saving drugs
- Right of sports lovers to watch cricket
- Right of voters to know the antecedents of electoral candidates

### (iv) Right to expression beyond national boundaries

The right to freedom of speech and expression extends beyond national boundaries. The question was considered by the Supreme Court in one of the cases related to impounding of a passport ‘in the interests of the general public’. The Court held that the direct and inevitable result of an order impounding a passport would violate the right to free speech and expression. In case, where a person plans to go abroad for the purpose of expressing himself, either through a lecture, dramatics, music, dance, etc., the impounding of his passport would impinge on his rights under Article 19(1)(a).

### (v) Right of the press to conduct interviews

This is a limited right, subject to the consent of the person being interviewed. In the case of *Prabha Dutt vs. Union of India*, the petitioner was seeking to interview the condemned prisoners, Ranga and Billa. The Supreme Court held that the interview may be conducted, provided the convicts gave their consent to being interviewed, and is subject to the rules specified under the jail manuals.

### (vi) Reporting court proceedings

Though in principle the press enjoys no higher status than an ordinary citizen, in practice, it does. Journalists enjoy special privileges of access to people and sitting

in the press bench, on account of the citizen's right to be informed on matters of public importance. A journalist, therefore, has the fundamental right to report judicial proceedings, though publicity of proceedings is not an absolute rule. For instance, the journalist must take care to protect the names of rape victims or riot victims. Similarly, family disputes warrant privacy to protect the children from unwanted publicity.

### **(vii) Reporting legislative proceedings**

The right to report proceedings of the Parliament and the state assemblies derives from the public's right to be informed about the debates and deliberations of the elected representatives on matters of public importance. This right is not absolute and is subject to restrictions under legislative privilege, which confers special rights to ensure freedom of speech for legislators to enable them to discuss matters of importance without the fear of inviting liability of any sort. This includes the right to control publication of legislative proceedings, the right of the House to punish members for their conduct in the Parliament, among others. The legislature can also punish for breach of privilege or for contempt of the House.

In the *Searchlight* case, a notice for breach of privilege was issued against the editor of *Searchlight*, a well-known English daily, for publishing an expunged portion of the proceedings in the Bihar state assembly. However, with advances in technology enabling live telecast of legislative proceedings, the concept of legislative privilege and contempt is obsolete.

### **(viii) Right to advertise**

Earlier, advertisements were excluded from the realm of free speech. However, later, the courts interpreted that the fundamental right to freedom of speech and expression included the right to advertise or the right to commercial speech. It argued that the traders and businessmen, who advertise for commercial gain, are no different from newspapers and other media, which are run as commercial enterprises.

### **(ix) Right of rebuttal**

The right to respond or the right to rebuttal was held by the Supreme Court in *LIC vs. Manubhai Shah* case. The case arose out of the publication in a newspaper of an article by the trustee of a consumer rights organization. The article criticized unfair practices adopted by the Life Insurance Corporation (LIC) on its policy holders. Responses of LIC and further rebuttal of the trustee were also published in the same newspaper. The case arose when the author of the counter had his views published in the in-house magazine of LIC, which refused to publish the viewpoint of the trustee. The Court ruled in favour of the trustee, stating that LIC did not have the exclusive privilege to publish or refuse to publish in an in-house magazine.

## **NOTES**

## NOTES

### (x) Compelled speech

This refers to the ‘must carry’ provision in a statute that could amount to infringement of the right to free speech. But the violation depends on the nature of the provision. Take, for instance, the obligation that a packaged food product must list all the ingredients, or the obligation that cigarette packets must carry a statutory warning that cigarette smoking is injurious to health. Such compulsory disclosures are meant to further the basic purpose of imparting relevant information, which enables the user to make a well-informed decision.

### (xi) Right to broadcast

The concept of speech and expression includes broadcast and the electronic media. In some of the cases, the Court held that the right of a citizen to exhibit films on the state broadcaster *Doordarshan* is part of the fundamental right guaranteed under Article 19(1)(a). The Court held that this right was similar to the right of a citizen to publish his views through any other media such as newspapers, magazines, advertisements, hoardings, etc.

### (xii) Right to entertain and be entertained

This covers the right of an individual to entertain as well as the right to be the audience in order to be entertained. In the context of a sports event, the Court held that both the participant in the sports event as well as its organizer have the right to entertain, though this right is restricted by the limited availability of the airwaves.

### (xiii) Right to fly the national flag

The courts have upheld the right of a citizen to fly the national flag, as it is an expression of the citizen’s loyalty and love for his nation. This right is, however, not an absolute one and one must keep in mind certain conditions for proper use.

#### Exhibit 5.2

##### Team Anna ups ante on the issue of bringing CBI under Lokpal

20 December 2011, 04.12 PM IST, PTI NEW DELHI: Team Anna today said extension of Winter Session of Parliament will be worth only if a strong Lokpal Bill is brought with CBI out of government control. ‘Extension will be worth if it is for a strong Lokpal with CBI out of government control and with Lokpal. Everything depends on the content of the bill,’ activist Kiran Bedi told PTI. She was reacting to reports about the Government deciding to extend the Winter Session by three days from December 27 to facilitate the passage of the Lokpal Bill and some other key legislations. Team Anna also asked the BJP whether it was determined on Lokpal as it was on issues of JPC probe into 2G scam and FDI in retail and cautioned the opposition party against ‘double speak’ on the question of bringing CBI under the ombudsman. ‘Is BJP as determined as it was in JPC and FDI on Lokpal? When will BJP make its stand on CBI categorical?’

Now that Congress' is evident!' Bedi said. She also warned the main opposition party that it will be a 'bigger loser if it does double speak' on CBI. 'People will not forgive them either,' she said. Bedi also said that it was 'frustrating to be waiting to see' what Congress does. 'It changes every minute,' she added. Her comments came as government raced against time to firm up Lokpal Bill in view of the looming threat of Anna Hazare to go on hunger strike from December 27 if Parliament fails to pass a strong Lokpal Bill. Pressing for inclusion of CBI under the Lokpal, she said, 'Unless independent Lokpal replaces government for oversight over CBI, expect no change in the anti-corruption systems. Let's not be fooled. Mere tweaking will not work. It will dilute whatever is remaining. If we leave any weak point in Lokpal bill and we do not see substantial reduction in corruption it shall be a dream shattered. Now or Never!' **Source:** Adapted from <http://economictimes.indiatimes.com/news/politics/nation/team-anna-ups-ante-on-the-issue-of-bringing-cbi-under-lokpal/articleshow/11180275.cms> (Accessed on 21 December 2011)

## NOTES

### Constitutional Restrictions on the Freedom of Speech and Expression

If the right to freedom of speech and expression was absolute, there would be no opportunity for people to defend themselves against written or spoken defamation. The opportunity to defend one's own self coheres with the right to freedom of expression, but is contrary to the idea that rights are absolute. That rights are relative and context-sensitive is reflected in various media law cases that have come up before the courts during the past few decades. For instance, what is libel to one person may be fair comment and exercise of the right to free speech and expression to another.

The freedom of speech and of the press does not grant an absolute right to express without any responsibility. Lord Denning, an Honorary Fellow of the British Academy, in his famous book, *Road to Justice*, stated that press acts as the watchdog to see that every trial is conducted fairly, openly and above board. However, the watchdog may sometimes break loose and has to be punished for misbehaviour.

The Indian Constitution outlines reasonable circumstances in which the right to freedom of speech and expression under Article 19 may be restricted. Reasonable restrictions can be imposed under the following heads:

- 1. Security of the State:** Reasonable restrictions can be imposed on the freedom of speech and expression, taking the security of the State into consideration. All statements that intend to jeopardize the security of the State, including activities which may overthrow the government, waging of war and rebellion against the government, external aggression or war, etc., may be restrained in the interest of the security of the State. Such restrictions do not refer to the ordinary violations of public order which do not involve any danger to the State.
- 2. Friendly relations with foreign states:** This ground was added by the Constitution (First Amendment) Act, 1951. The State can impose

## NOTES

reasonable restrictions on the freedom of speech and expression, if it tends to jeopardize the friendly relations of India with foreign states.

**3. Public order:** This ground was added by the Constitution (First Amendment) Act, 1951, in order to deal with the situation arising from the Supreme Court's decision in *Romesh Thapar's* case. The expression 'public order' connotes the sense of public peace, safety and tranquillity.

In another case, the Supreme Court clarified that mere criticism of the government does not necessarily disturb public order. However, if someone states something deliberately, tending to hurt the religious feelings of a particular community, it will be held valid as a reasonable restriction aimed to maintain public order.

**4. Decency and morality:** The word 'obscenity' is identical with the word 'indecent' of the Indian Constitution. The Indian courts have chosen to adopt the old and outdated English test, known as Hicklin's test, which was based upon the effect of a publication on the most vulnerable members of the society, whether or not they were likely to read it. The Supreme Court chose to apply this test in the case of *Ranjit D. Udeshi vs. State of Maharashtra*, and upheld the conviction of a bookseller and his partners for being in possession of a book containing obscene material. The book was D.H. Lawrence's novel, *Lady Chatterley's Lover*.

**5. Contempt of court:** The constitutional right to freedom of speech would not allow a person to disrespect the courts. The expression, contempt of court, has been defined under Section 2 of the Contempt of Courts Act, 1971. The term refers to civil contempt or criminal contempt under this Act. But judges do not have any general immunity from criticism of their judicial conduct, provided that it is made in good faith and is genuine criticism, and not any attempt to impair the administration of justice. In the case of *In Re: Arundhati Roy*, the Supreme Court followed the view taken in the American Supreme Court which observed:

'If men, including judges and journalists, were angels, there would be no problem of contempt of court. Angelic judges would be undisturbed by extraneous influences and angelic journalists would not seek to influence them.'

**6. Defamation:** Clause (2) of Article 19 prevents any person from making any statement that injures the reputation of another. With the same view, defamation has been criminalized in India by incorporating it into Section 499 of the Indian Penal Code (IPC).

**7. Incitement to an offence:** This ground was also added by the Constitution (First Amendment) Act, 1951. The Constitution prohibits a person from making any statement that incites people to commit offence.

- 8. Sovereignty and integrity of India:** This ground was also added subsequently by the Constitution (Sixteenth Amendment) Act, 1963. This is aimed to prohibit anyone from making statements that challenge the sovereignty and integrity of India.

#### Check Your Progress

3. Under what article of the Universal Declaration of Human Rights is press freedom guaranteed?
4. List one right that is included in the right to free speech and expression.

#### NOTES

### 5.4 RESPONSIBILITY OF THE PRESS

Journalism began as a natural activity of providing news and information in its initial days. During the turbulent days of the French Revolution, journalism became the torchbearer of revolutionary thinking and helped the bourgeoisie to accomplish their historic role. It was afterwards that the press was seen as the fourth estate of democracy. It became the fundamental duty of the press to protect the democratic principles of the state.

In the later days of bourgeois democracy, the interests of various groups led to a new kind of journalism that was supposed to work for the business interest of its owners. There would be a lot of commonality in thinking and ideology of various newspapers but on certain issues and at certain times some newspapers would speak a language that would be threatening for the powers that be. It is here that the term 'lobby' came into being.

The journalism and media was supposed to be a service and in many cases like in India it acquired the role of pioneer for the mission of the freedom of the Indian people from the British rule. It is obvious that the purpose of journalism has changed with the emergence of new technologies as well as the social changes from a traditional feudal society to a modern and now the post-modern societies.

We find a few purposes of journalism and mass media encompass public service, seeking truth, making itself a successful commercial venture, creating public opinion on the matters of national importance and persuading the masses during the election. Apart from these purposes, newspapers and other media are needed for transmitting commercial and business information in the form of advertisements, which is one of the biggest revenue earner for any news organization.

#### Informed Citizenry

The principal objective of journalism is to facilitate a well-informed citizenry for the socio-political structure. In his book *Democracy and the News* American sociologist Herbert J. Gans states that journalism itself 'can do little to reduce the

political imbalance between citizens and the economic, political and other organizations’.

The theory of democracy in journalism still relies on an assumption that

- an informed citizenry means an engaged citizenry,
- an engaged citizenry is more informed and more participatory, and
- the result is a more democratic society.

## NOTES

### **Public Service**

Journalism actually started as an activity of public service. It serves the people by giving them necessary information regarding the political and social changes, law and order situations, weather, sports, finance, etc. In the very early days it was also publishing governmental orders and other information meant to reach the citizens.

In various third world countries, where the liberation movements were at their peak, journalism found another purpose. It took an active part in supporting such struggle and hence it acquired the role of missionary. In India, journalism was considered as a mission rather than an occupation for many years.

### **Search of Truth**

Right from its inception the profession of journalism has projected itself as the seeker of truth in the form of an activity of academic research. So journalism was pursued by intellectuals. Moreover, the journalists did not want to give up their zeal to know about the truth which they had learned during their education. However, the nature of truth sought by journalists is at times quite far from that a researcher would be seeking. There is a kind of pragmatic attitude attached to the process and activity of seeking truth in journalism.

### **Commercial Venture**

Journalism was never considered as charity, there are costs involved in publishing and distribution of newspapers. Today, the costs of running the private radio and television and even magazines and newspapers are very high. Thus, whether we like it or not, journalism has come to be dominated as a commercial venture. It was also a question of survival of journalists for which the earning of money became a valid purpose.

### **Public Opinion and Persuasion**

Journalism is an effective means of transmitting messages to the people who require various kinds of information to meet different needs in their lives. Hence, newspapers have another good purpose of assessing the public opinion on the key national issues. Further, they also venture into making public opinion during the elections and other national matters. The capability of journalism to persuade is very handy for this purpose.



There is a vast literature available in libraries and elsewhere on the role of newspapers in forming public opinion and also persuading people to have a particular attitude towards things and situations. Most of the time, the persuasion is very subtle and there are hidden biases behind such persuasion. However, journalism is also capable of entering into propaganda mode where the act of persuasion becomes obvious to the public.

It may not be journalism as such but it was the newspapers and other media that took to extensive advertising not only for sustenance but for profit making as well. Advertising is another activity where persuasion is at its peak. In recent times, unfortunately the greed for profits has also influenced the act of journalism as you may find newspapers stuffed with too much consumerist advertorials and paid news.

### **Promotion of Different Perspectives**

The profession of journalism promotes ideology and values with an objective to project a multiperspectival approach. Journalism informs citizens about:

- the political diversity of the country,
- the politically significant ideas and activities of their fellow citizens, and
- what types of issues concern the citizens (which our elected representatives are also required to know)

For these objectives the journalists are required to be multiperspectival — to include all the essential viewpoints from people having different interests, values and incomes. Multiperspectivism refers to reporting all ideas which can resolve issues and help in solving problems, even if the ideas come from the side of ideologically tiny groups.

### **Independent Monitor of Power**

Journalism possesses an extraordinary ability to function as the watchdog over such individuals and institutions whose position and power has a great bearing on the majority of citizens. Journalists have the responsibility to protect this watchdog freedom by not tainting it in petty use or exploit it for commercial gains.

### **Provide Reliable and Accurate Information**

It comprises various roles—helping define community, evolving common language and shared knowledge, finding a community's objectives, specifying heroes and villains, and push people out of complacency. It also comprises other functions, e.g., entertainment, working as watchdog and providing voice to the voiceless.

Finally, we find that the basic purpose of journalism still remains the dissemination of information and news, though this activity has found many secondary purposes over a period due to the changing political-economical situation as well as the rapid growth of mass media technologies.

## **NOTES**

## NOTES

### National Development

It works as an agent of change in developmental perspective. Further, it works as a liaisoning agent between the government and the people for achieving development.

### Cultural Integration

The purpose of journalism is to import positive sub-cultural traits from the other cultures and urge the people to adapt it. Further, it also tries to discard the negative aspect of the internal culture.

#### 5.4.1 Theories of Press

The press does not function in vacuum in society, it always takes on the form and coloration of the social and political structures within which it operates. The scholars Fred, Peterson and Wilbur Schramm in their book called *Four Theories of the Press* first discussed the different theories of the press. According to them, the four theories of the press are as follows:

1. **Authoritarian:** This theory was developed in 17th century England, and this it is the oldest of the four theories. The authoritarian theory describes the press to be a media system that acts as a propaganda tool for a monarch, dictator or the government. Under this theory, the freedom of information is limited and the primary role of the press is to educate the masses on the policies of government and prevent threats to its rule by utilizing censorship.
2. **Soviet Communist Theory:** This theories built upon the authoritarian theory of the press and imposed even greater restrictions on the press. The Soviet Communist Theory describes a system in which the state owns or controls all forms of mass media. Under this theory, the role of the press is to bring about societal change by inculcating communist values in the masses and denouncing democratic regimes.
3. **Libertarian Theory:** This theory describes a contrasting press, which is free to report on the government. Under this theory, freedom of information is guaranteed with no restrictions or censorship. Under the libertarian theory, the press is able to play the role of a watchdog and keep the ruling party in check. The theory considers the public as being rational and being able to decide for themselves what is good and what is bad.
4. **Social Responsibility Theory:** In most democratic societies, the press belongs to the public, and yet, in capitalist societies, this is always under threat. Advertisers and the owners of major companies can always influence the media in the same way that governments can. The social Responsibility Theory of the press assumes that the press should observe a code of conduct and should not feel pressured by big businesses and investors. Under this theory, the press has a social responsibility to serve the public without any outside interference.

### Check Your Progress

5. What role did journalism play during the French Revolution?
6. What is the principal objective of journalism?
7. What is the oldest theory of the press?

### NOTES

## 5.5 ANSWERS TO CHECK YOUR PROGRESS QUESTIONS

1. There are different versions regarding the earliest newspaper in the world. Some say that the first newspaper was started by an American, John Campbell in 1704. There are others who consider *Relation aller Furnemmen und gedenckwürdigen Historien* as the first newspaper. This newspaper in German language was published in Strasbourg from 1605 onwards. According to the Encyclopaedia Britannica, the first newspaper in the world is *Avisa Relacion Oder Zeitung*, published in 1609 in Germany.
2. The political system uses journalism for dissemination of news and information for its own perpetuation.
3. Press freedom is globally and ideally guaranteed by Article 19 of the Universal Declaration of Human Rights.
4. The right to free speech and expression includes the right not only to publish but also to circulate information and opinion. Without this, the right to free speech and expression would carry little meaning.
5. During the turbulent days of the French Revolution, journalism became the torchbearer of revolutionary thinking and helped the bourgeoisie to accomplish their historic role
6. The principal objective of journalism is to facilitate a well-informed citizenry for the socio-political structure.
7. The authoritarian theory of the press was developed in 17th century England and is the oldest of the four theories of the press.

## 5.6 SUMMARY

- Journalism is reporting of daily events. In modern times, journalism is seen as the profession of gathering news and information, processing it and finally disseminating it through a particular media.
- The news and information so gathered is required to be relevant to the society. It is for this reason that journalism, popularly known as the press,

## NOTES

has been defined as an institution of mass communication essentially devoted to public service.

- Journalism is as old an activity as the primitive human societies. It has been a common human tendency to share new things with the fellow beings.
- The history of printing is traced back to 868 AD when Chinese used the movable types for printing.
- Apart from disseminating news and information in society in public interest, the press is also seen as a bridge between the government and the people, in the sense that it communicates the policy and programmes of the government to the people.
- The Press conveys the grievances and perception of public about issues of the society to the powers that be.
- The political system uses the press for dissemination of news and information for its own perpetuation.
- The press has to function as the watchdog of democracy by constantly being vigilant towards the functioning of the other three pillars, i.e., legislature, executive and judiciary.
- Press freedom is a logical extension of man's undeniable freedom of expression. At present, press freedom is a universal phenomenon, in spite of the ideological differences in several socio-political systems worldwide.
- Though freedom of press is a much talked about concept, interestingly, it is not mentioned as such in the Indian Constitution. It is understood to be covered under the provisions of Article 19 and derives its rights from the freedom of speech and expression, available to the citizens of India.
- Contrary to the Indian Constitution, the First Amendment to the Constitution of the United States of America makes a specific reference to the freedom of press.
- Article 19(1)(a) covers the right to express oneself by word of mouth, writing, printing, picture, or in any manner. It includes the freedom of communication and the right to propagate or publish one's views. The communication of ideas may be through any medium—newspaper, magazine, movie, electronic media or audio-visual media.
- If the right to freedom of speech and expression was absolute, there would be no opportunity for people to defend themselves against written or spoken defamation.
- The freedom of speech and of the press does not grant an absolute right to express without any responsibility.
- A few purposes of journalism and mass media include public service, seeking truth, making itself a successful commercial venture, creating public opinion

on the matters of national importance and persuading the masses during the election.

- The profession of journalism promotes ideology and values with an objective to project a multiperspectival approach.
- Journalism possesses an extraordinary ability to function as the watchdog over such individuals and institutions whose position and power has a great bearing on the majority of citizens.
- The basic purpose of journalism still remains the dissemination of information and news, though this activity has found many secondary purposes over a period due to the changing political-economical situation as well as the rapid growth of mass media technologies.
- The scholars Fred, Peterson and Wilbur Schramm in their book called *Four Theories of the Press* first discussed the different theories of the press. According to them, the four theories of the press are Authoritarian, Soviet Communist Theory, Libertarian Theory and Social Responsibility Theory.

## NOTES

---

### 5.7 KEY WORDS

---

- **Feudal Society:** It is a society where a peasant or worker known as a vassal received a piece of land in return for serving a lord or king, especially during times of war.
- **Status Quo:** It means the existing state of affairs, especially regarding social or political issues.
- **Bourgeois Democracy:** It essentially is a government that serves in the interests of the bourgeois class.
- **French Revolution:** It was an uprising in France against the monarchy from 1789 to 1799 which resulted in the establishment of France as a republic.

---

### 5.8 SELF-ASSESSMENT QUESTIONS AND EXERCISES

---

#### Short-Answer Questions

1. What do you understand by journalism?
2. What is press freedom?
3. Write a short-note on some of the cases related to the freedom of the press in India.
4. What are the assumptions of the theory of democracy in journalism?
5. List the different theories of the press.

## NOTES

### Long-Answer Questions

1. Discuss the functions of the press.
2. Describe the constitutional status of the media in India.
3. Examine the rights included in freedom of speech and expression in India.
4. Describe the reasonable restrictions that can be imposed under the freedom of speech laws in India.
5. Explain the responsibility of the press in a society.

---

### 5.9 FURTHER READINGS

---

- Mcquail, Denis. 2013. *Journalism and Society*. New Delhi: Sage Publications.
- Bro, Peter. 2018. *Models of Journalism: The Functions and Influencing Factors*. London: Routledge.
- Burns, Lynette Sheridan. 2002. *Understanding Journalism*. New Delhi: Sage Publications.
- Raghavan, G.N.S. 1994. *Press in India: A New History*. New Delhi: Gyan Publishing House.
- Sharma, K. Suresh. 2006. *Press in India*. New Delhi: Vista International Publishing House.
- Parthasarathy, Rangaswami. 1984. *Basic Journalism*. New Delhi: Macmillan India Limited.

---

## UNIT 6 CODES AND ETHICS OF JOURNALISM

---

### NOTES

#### Structure

- 6.0 Introduction
- 6.1 Objectives
- 6.2 Current Trends in Journalism
- 6.3 Press Codes and Ethics of Journalism
  - 6.3.1 A Code of Ethics for the Indian Press
- 6.4 Answers to Check Your Progress Questions
- 6.5 Summary
- 6.6 Key Words
- 6.7 Self Assessment Questions and Exercises
- 6.8 Further Readings

---

### 6.0 INTRODUCTION

---

In the previous unit, you learnt about the concept and function of journalism. You also learnt the meaning of press freedom and the responsibility of the press. In this unit, we will discuss the codes and ethics in journalism in detail. Journalism ethics and standards comprise the principles of ethics and of good practice that are applicable to the specific challenges faced by journalists globally. This is a journalist's professional 'code of ethics' or the 'canons of journalism'. These codes and canons commonly appear in statements drafted by both professional journalism associations and individual print, broadcast, and online news organizations. The unit will begin with a discussion on the current trends in journalism.

---

### 6.1 OBJECTIVES

---

After going through this unit, you will be able to:

- Describe the current trends in journalism
- Discuss the codes and ethics of journalism
- Examine the code of ethics for the Indian Press

---

### 6.2 CURRENT TRENDS IN JOURNALISM

---

Journalism has changed a lot over the decades. It was a simple process of gathering, processing and disseminating the information. Today, the competitive markets have posed many responsibilities and the nature and work of journalists have changed. On the one hand, we find big conglomerates pumping huge amount of money in

## NOTES

different media technologies and on the other hand there are people with relatively smaller capital investing on media. The technology and the economics of management of media has forced the companies to employ journalist with multiple skills.

### **Convergent Journalism**

Convergent journalism is the name given to multitasking in journalism where a journalist is expected to not only produce a report for the newspaper, he is also required to give it orally for radio and/or television and at the same time give a brief one for mobile news services as well. A journalist needs to be trained in many skills like writing for newspapers, radio, television, online and mobile news service. For example, the Times of India (Bennett, Coleman & Co.) runs Times of India (newspaper), Times Now (TV channel), Indiatimes.com (website portal) and Radio Mirchi (private FM channel). Gone are the days when the journalism institutes were training journalist in the specialized area for a specific media only.

The convergent journalism is the end result of the convergence of media and communication technology. The most popular forms of convergent journalism are to be found in media houses owning more than one type of media. Today, almost all newspapers are having their hard copy editions and the online editions. They have also taken interest in the mobile news service as it gives them a better market reach. Even the radio and television houses have their online services where they not only provide the audio-visual content, but they also give textual reports. Looking at the economy of media management they prefer multitasking journalists instead of having specialists in a particular media, though the demand for specialization in various kinds of journalism like economic journalism, sports journalism, defence journalism, etc., has also increased over the years.

### **Online Journalism**

We are living in an age where speed matters. The print journalism in spite of being analytical used to appear stale in comparison to the breaking news scenario of television a few years back. Today even the television news looks less fast than the SMS messaging or the various news services incorporated by the mobile service providers.

The revolution of information technology has changed the world dramatically in the past two decades. From slow word processing computers, the IT has moved towards faster processors, increased bus speed and bandwidth to allow the audio and video to be played in real time. The communication technology has also moved away from the slow and narrow copper lines to optical cable capable of carrying various signals at the same time. The widening of pathways has become possible due to the conversion of signals from analogue to digital. The information superhighway works on broadband connectivity of ever-increasing bites.

It has brought the online journalism at the forefront. Newspapers have responded well to the new culture of paperless world and have started moving in



a direction that is not only convenient but economical. Many newspapers have already started their online editions that could be accessed on the Internet by paying a certain amount as subscription. In order to keep the conventional layout of the newspaper that has become a matter of habit for many of us, they also have the replica of the hard copy on the Internet. This combination of web journalism and mobile news services is the most recent trend in the profession of journalism.

### **Fashion Journalism**

Fashion journalism comprises the reports and articles on the fashion world. The journalists in this field are also called as fashion editors or fashion writers. The key duty is to cover the most up-to-date trends and happenings in the fashion business. It also comprises developing lifestyle articles. These fashion articles are generally found in the supplements in newspapers and specialized magazines. Presently there are many television channels which cater to fashion only. It provides abundant opportunities for journalists having a passion to cover such topics.

### **Celebrity Journalism**

As suggested by the name, the journalist in this field deals with the news and events connected to celebrities from the various domains of life. It includes celebrities from the fields like sports, dance, music, art, politics, etc. This kind of journalism is concerned about the news related to the celebrities' professional and personal lives. Interestingly, reporting gossip is also one of the aspects of celebrity journalism. However, journalists are usually accused of misrepresenting and misconstruing news or quotes in a manipulative or intentional manner. This kind of journalism is especially popular with magazines, newspapers and television.

### **Sports Journalism**

Though sports belong to entertainment category, sports journalism is one of the most important aspects of journalism. For reporting sports events, the journalist should have proper knowledge of the game including points, rules and regulations etc. In sports journalism, the journalists spend hours reporting on a specific sports event. A journalist is required to report the precise facts and statistics about that event. In sports journalism, interviews with celebrity sports stars are one of the interesting features. Even though the lovers of sports watch the live coverage through various media channels, still there are scores of people who still prefer reading or watching comprehensive details of the event.

### **Citizen Journalism**

The citizen journalism is just not just the domain of professional journalists. All citizens possess the right to function as journalists and report news to the media. With the emergence of the mobile communication, the importance of citizen journalism quadrupled. Anybody can take a picture of an event and can send it to any media organisation through MMS and get it telecasted. The conscious individuals from the society collect and report news to the media. They voluntarily

## **NOTES**

## NOTES

participate to further the cause of the media. Many a times they highlight critical issues that might have been missed or overlooked by the mainstream media.

### **Environmental Journalism**

The environmental cause is getting stronger as we come across the effects of our blind race on the path of development with the use of environmentally unsustainable schemes. We have the journalists who have a preference for covering the issues concerned with the environment and its conservation and protection. Environmental journalists bring into focus various issues like greenhouse gas emission, melting polar ice, deforestation, extinction of various flora and fauna, etc.

### **Business and Finance Journalism**

In this kind of journalism, the reporter or journalist covers detailed reports about the latest in the world of business, e.g., product launches, stock market conditions, loans, the economic conditions, etc. We have many shows solely dedicated to the business news on television. Further, in newspapers as well one can find a specific section on these subjects.

### **Ambush Journalism**

Ambush journalism connotes the aggressive tactics taken up by the journalists to abruptly confront and question the individuals who would otherwise not speak to the media. Particularly the television journalists have taken the practice on a large scale. For instance, news shows such as The O'Reilly Factor and 60 Minutes and by Geraldo Rivera and other local television reporters conduct investigations on various socially critical issues.

Some media people have sharply criticized the practice as being very unethical and sensational in nature. However, others have defended it on the grounds that it is the only means to get an opportunity to avail comments from those who are generally beyond the reach of the media. The sting operation performed by an Indian news channel, India TV, on the involvement of umpires in match fixing is an example of ambush journalism.

### **Churnalism**

In churnalism form of journalism the press releases, wire stories and other kinds of pre-packaged material are utilized to generate articles for the newspapers and other news media. It is done to meet the increasing pressures of cost and time without performing further checking or research.

The degree of churnalism form of journalism has increased to the point that various stories that are found in the press are not original anymore. The decline of original journalism is related to a corresponding increase in public relations.

## Gonzo Journalism

Gonzo journalism is a form of journalism that is popularized by the American writer Hunter S. Thompson. Among other stories and books he authored *Fear and Loathing in Las Vegas*, *Fear and Loathing on the Campaign Trail '72* and *The Kentucky Derby is Decadent and Depraved*. This kind of journalism is specialized on account of its rough language, punchy style and apparent disregard for the conventional journalistic writing customs and forms. More significantly, the conventional objectivity of the journalist is discarded by immersing into the story itself, just like in New Journalism. Further, the reportage is taken from a participatory and first-hand perspective, even sometimes using an author surrogate like Thompson's Raoul Duke.

Gonzo journalism tries to represent a multi-disciplinary viewpoint on a specific story by drawing from sports, popular culture, and philosophical, political and literary sources. This kind of journalism has been categorized as eclectic or untraditional in nature. It is the defining feature of the popular magazines like the *Rolling Stone*. It possesses a great deal in common with new journalism and on-line journalism.

### Check Your Progress

1. What is convergent journalism?
2. Who popularized gonzo journalism?

## 6.3 PRESS CODES AND ETHICS OF JOURNALISM

Generally there are causes of dissatisfaction and complaints against journalists. People feel that they are biased, they are not truthful or they take sides. The matter of fact is that journalists work under many kinds of pressures and the very nature of news writing is such that in spite of the good intentions of the journalists it becomes difficult to satisfy everyone. Journalist associations and many other bodies such as press councils have evolved certain guidelines for the journalists. Over the years, there have been various codes of ethics agreed and endorsed by the journalists and editors. Although these are not as 'official' as an oath, nevertheless they are generally accepted at the practical level.

The American Society of Newspaper Editors was founded in 1922. It made definite parameters meant to specify the functioning of journalists. These were known as the 'Canons of Journalism'. The list given below summarizes these canons:

1. Responsibility (of newspaper and journalist)
2. Freedom of the Press ('a vital right of mankind')

## NOTES

## NOTES

3. Independence (fidelity to the public interest)
4. Sincerity, Truthfulness, Accuracy (good faith with reader)
5. Impartiality (news reports free from opinion or bias)
6. Fair Play, Decency (recognition of private rights, prompt correction of errors)

It is interesting to note that these canons of journalism were also described by Casper Yost in his book *Principles of Journalism* in 1924 and they still hold good though now we have added a few more things to it, as the practice of journalism has shown us the newer dimensions of the canons. The canons of journalism have turned out to be similar to the code of medical ethics by which every doctor has to abide as he takes oath of it while passing out.

In this section we would discuss various aspects of good practices in journalism. We would start our exploration with the canons as described by Yost (1924):

### **Responsibility**

The right of a newspaper to attract and hold readers is restricted by nothing but considerations of public welfare. The use a newspaper makes of the share of public attention it gains serves to determine its sense of responsibility, which it shares with every member of its staff. A journalist who uses his power for any selfish or otherwise unworthy purpose is faithless to high trust.

### **Freedom of Press**

Freedom of the press is to be guarded as a vital right of mankind. It is the unquestionable right to discuss whatever is not explicitly forbidden by law, including the wisdom of any restrictive statute.

### **Independence**

Freedom from all obligations except that of fidelity to the public interest is vital. Promotion of any private interest contrary to the general welfare, for whatever reason, is not compatible with honest journalism. The so-called news communications from private source should not be published without public notice of their source or else substantiation of their claims to value as news, both in form and substance.

Partisanship in editorial comment which knowingly departs from the truth does violence to the best spirit of journalism; in the news columns it is subversive of a fundamental principle of the profession.

### **Sincerity, Truthfulness and Accuracy**

Good faith with the reader is the foundation of all journalism worthy of the same. By every consideration of good faith a newspaper is constrained to be truthful. It

is not to be excused for lack of thoroughness or accuracy within its control or failure to obtain command of these essential qualities. Headlines should be fully warranted by the content of the articles which they surmount.

### **Impartiality**

Sound practice makes clear distinction between news reports and expression of opinion. News reports should be free from opinion or bias of any kind. This rule does not apply to the so-called special articles unmistakably devoted to advocacy or characterized by a signature authorizing the writer's own conclusions and interpretations.

### **Fair Play**

A newspaper should not publish unofficial charges affecting reputation or moral character without opportunity given to the accused to be heard; right practice demands the giving of such opportunity in all cases of serious accusation outside judicial proceedings.

A newspaper should not invade private rights or feelings without sure warrant of public right as distinguished from public curiosity.

It is the privilege, as it is the duty, of a newspaper to make prompt and complete correction of its own serious mistake of facts or opinion, whatever their origin.

### **Decency**

A newspaper cannot escape conviction of insincerity if while professing high moral purpose it supplies incentives to base conduct, such as are to be found in details of crime and vice, publication of which is not demonstrably for the general good. Lacking authority to enforce its canons, the journalism here represented can but express the hope that deliberate pandering to vicious instincts will encounter effective public disapproval or yield to influence of a preponderant professional condemnation.

### **Ethical Standards**

Similarly, the International Federation of Journalists (IFJ) has also prepared a code of conduct for journalists. Indian journalist organizations like All India Newspaper Employees Federation, Indian Journalists' Union and National Union of Journalists are the members of this organization.

The International Federation of Journalists, according to its website, is the world's largest organization of journalists. First established in 1926, it was re-launched in 1946 and again, in its present form, in 1952. Today the Federation represents around six lakh members in more than 100 countries. The IFJ Code of Conduct, first adopted in 1954, provides a code of ethics adopted by all national representative journalists' organizations in Europe. Therefore, the IFJ Code of

## **NOTES**

Conduct provides the basis for a common understanding on ethical issues through voluntary adoption of journalists and publishers. In this area IFJ sees no active role for national governments.

## NOTES

### **Declaration of Principles on the Conduct of Journalists**

This international Declaration is proclaimed as a standard of professional conduct for journalists engaged in gathering, transmitting, disseminating and commenting on news and information in describing events.

1. Respect for truth and for the right of the public to truth is the first duty of the journalist.
2. In pursuance of this duty, the journalist shall at all times defend the principles of freedom in the honest collection and publication of news, and of the right of fair comment and criticism.
3. The journalist shall report only in accordance with facts of which he/she knows the origin. The journalist shall not suppress essential information or falsify documents.
4. The journalist shall use only fair methods to obtain news, photographs and documents.
5. The journalist shall do the utmost to rectify any published information which is found to be harmfully inaccurate.
6. The journalist shall observe professional secrecy regarding the source of information obtained in confidence.
7. The journalist shall be aware of the danger of discrimination being furthered by the media, and shall do the utmost to avoid facilitating such discrimination based on, among other things, race, sex, sexual orientation, language, religion, political or other opinions, and national or social origins.
8. The journalist shall regard the following as grave professional offences:
  - Plagiarism;
  - Malicious misrepresentation;
  - Calumny, slander, libel, unfounded accusations;
  - Acceptance of a bribe in any form in consideration of either publication or suppression.
9. Journalists worthy of the name shall deem it their duty to observe faithfully the principles stated above. Within the general law of each country the journalist shall recognise in professional matters the jurisdiction of colleagues only, to the exclusion of every kind of interference by governments or others.

(Adopted by 1954 World Congress of the IFJ. As amended by the 1986 World Congress)

## **Press Councils and Ethics of Journalism**

In many countries including India, there are autonomous or independent institutions that look after the grievances of public regarding the work of newspapers and other periodicals. In Britain there was Press Council in the earlier days, but as it was felt that it is not very representative and effective so a new body called the Press Complaints Commission (PCC) was formed. In India there is an autonomous body chaired by a retired justice of the Supreme Court of India, which is called the Press Council of India. Similarly, in many other countries there are Press Councils that look into the grievances of public regarding the functioning of newspapers and the conduct of journalists. The process of nominations in these organizations may differ, but the journalists and media organizations are adequately represented in them along with representatives from almost all walks of life.

After the expansion of privately owned television networks in India, there have been many complaints from various groups of people regarding the news coverage and entertainment programmes. In the absence of any regulatory body for the television and the new media, public is forced to go to courts for getting their grievances redressed. In recent years, the Government of India has tried to make such a regulatory body, but it has been opposed tooth and nail by the media organizations and journalists. Some news and entertainment channels have made an independent organization called News Broadcasters' Association and have come up with certain codes of conduct. However, the issues have not been properly addressed till date.

In this subsection we will look at the code of conduct as suggested by the Press Complaints Commission (PCC) and the Press Council of India (PCI) as they are much more comprehensive than those of the journalist associations mentioned above.

The Press Complaints Commission, situated in London, is charged with enforcing the following Code of Practice, which was framed by the newspaper and periodical industry and was ratified by the PCC in September 2009.

### **The editors' code**

All members of the press have a duty to maintain the highest professional standards. The Code, which includes this preamble and the public interest exceptions below, sets the benchmark for those ethical standards, protecting both the rights of the individual and the public's right to know. It is the cornerstone of the system of self-regulation to which the industry has made a binding commitment.

It is essential that an agreed code be honoured not only to the letter but in the full spirit. It should not be interpreted so narrowly as to compromise its commitment to respect the rights of the individual, nor so broadly that it constitutes an unnecessary interference with freedom of expression or prevents publication in the public interest.

## **NOTES**

## NOTES

It is the responsibility of editors and publishers to apply the Code to editorial material in both printed and online versions of publications. They should take care to ensure it is observed rigorously by all editorial staff and external contributors, including non-journalists, in printed and online versions of publications.

It is said that the editors should co-operate swiftly with the PCC in the resolution of complaints. Any publication judged to have breached the Code must print the adjudication in full and with due prominence, including headline reference to the PCC.

### 1. Accuracy

- (i) The Press must take care not to publish inaccurate, misleading or distorted information, including pictures.
- (ii) A significant inaccuracy, misleading statement or distortion once recognised must be corrected, promptly and with due prominence, and - where appropriate - an apology published.
- (iii) The Press, whilst free to be partisan, must distinguish clearly between comment, conjecture and fact.
- (iv) A publication must report fairly and accurately the outcome of an action for defamation to which it has been a party, unless an agreed settlement states otherwise, or an agreed statement is published.

### 2. Opportunity to reply

A fair opportunity for reply to inaccuracies must be given when reasonably called for.

### 3. \*Privacy

- (i) Everyone is entitled to respect for his or her private and family life, home, health and correspondence, including digital communications.
- (ii) Editors will be expected to justify intrusions into any individual's private life without consent. Account will be taken of the complainant's own public disclosures of information.
- (iii) It is unacceptable to photograph individuals in private places without their consent.

*Note* - Private places are public or private property where there is a reasonable expectation of privacy.

### 4. \*Harassment

- (i) Journalists must not engage in intimidation, harassment or persistent pursuit.
- (ii) They must not persist in questioning, telephoning, pursuing or photographing individuals once asked to desist; nor remain on their property when asked



to leave and must not follow them. If requested, they must identify themselves and whom they represent.

- (iii) Editors must ensure these principles are observed by those working for them and take care not to use non-compliant material from other sources.

#### **5. Intrusion into grief or shock**

- (i) In cases involving personal grief or shock, enquiries and approaches must be made with sympathy and discretion and publication handled sensitively. This should not restrict the right to report legal proceedings, such as inquests.
- \* (ii) When reporting suicide, care should be taken to avoid excessive detail about the method used.

#### **6. \*Children**

- (i) Young people should be free to complete their time at school without unnecessary intrusion.
- (ii) A child under 16 must not be interviewed or photographed on issues involving their own or another child's welfare unless a custodial parent or similarly responsible adult consents.
- (iii) Pupils must not be approached or photographed at school without the permission of the school authorities.
- (iv) Minors must not be paid for material involving children's welfare, nor parents or guardians for material about their children or wards, unless it is clearly in the child's interest.
- (v) Editors must not use the fame, notoriety or position of a parent or guardian as sole justification for publishing details of a child's private life.

#### **7. \*Children in sex cases**

1. The press must not, even if legally free to do so, identify children under 16 who are victims or witnesses in cases involving sex offences.
2. In any press report of a case involving a sexual offence against a child -
  - (i) The child must not be identified.
  - (ii) The adult may be identified.
  - (iii) The word "incest" must not be used where a child victim might be identified.
  - (iv) Care must be taken that nothing in the report implies the relationship between the accused and the child.

#### **8. \*Hospitals**

- (i) Journalists must identify themselves and obtain permission from a responsible executive before entering non-public areas of hospitals or similar institutions to pursue enquiries.

### **NOTES**

**NOTES**

- (ii) The restrictions on intruding into privacy are particularly relevant to enquiries about individuals in hospitals or similar institutions.

**9. \*Reporting of crime**

- (i) Relatives or friends of persons convicted or accused of crime should not generally be identified without their consent, unless they are genuinely relevant to the story.
- (ii) Particular regard should be paid to the potentially vulnerable position of children who witness, or are victims of, crime. This should not restrict the right to report legal proceedings.

**10. \*Clandestine devices and subterfuge**

- (i) The press must not seek to obtain or publish material acquired by using hidden cameras or clandestine listening devices; or by intercepting private or mobile telephone calls, messages or emails; or by the unauthorized removal of documents or photographs; or by accessing digitally-held private information without consent.
- (ii) Engaging in misrepresentation or subterfuge, including by agents or intermediaries, can generally be justified only in the public interest and then only when the material cannot be obtained by other means.

**11. Victims of sexual assault**

The press must not identify victims of sexual assault or publish material likely to contribute to such identification unless there is adequate justification and they are legally free to do so.

**12. Discrimination**

- (i) The press must avoid prejudicial or pejorative reference to an individual's race, colour, religion, gender, sexual orientation or to any physical or mental illness or disability.
- (ii) Details of an individual's race, colour, religion, sexual orientation, physical or mental illness or disability must be avoided unless genuinely relevant to the story.

**13. Financial journalism**

- (i) Even where the law does not prohibit it, journalists must not use for their own profit financial information they receive in advance of its general publication, nor should they pass such information to others.

- (ii) They must not write about shares or securities in whose performance they know that they or their close families have a significant financial interest without disclosing the interest to the editor or financial editor.
- (iii) They must not buy or sell, either directly or through nominees or agents, shares or securities about which they have written recently or about which they intend to write in the near future.

## NOTES

### 14. Confidential sources

Journalists have a moral obligation to protect confidential sources of information.

### 15. Witness payments in criminal trials

- (i) No payment or offer of payment to a witness - or any person who may reasonably be expected to be called as a witness - should be made in any case once proceedings are active as defined by the Contempt of Court Act 1981.

This prohibition lasts until the suspect has been freed unconditionally by police without charge or bail or the proceeding are otherwise discontinued; or has entered a guilty plea to the court; or, in the event of a not guilty plea, the court has announced its verdict.

- \* (ii) Where proceedings are not yet active but are likely and foreseeable, editors must not make or offer payment to any person who may reasonably be expected to be called as a witness, unless the information concerned ought demonstrably to be published in the public interest and there is an overriding need to make or promise payment for this to be done; and all reasonable steps have been taken to ensure no financial dealings influence the evidence those witnesses give. In no circumstances should such payment be conditional on the outcome of a trial.
- \* (iii) Any payment or offer of payment made to a person later cited to give evidence in proceedings must be disclosed to the prosecution and defence. The witness must be advised of this requirement.

### 16. \*Payment to criminals

- (i) Payment or offers of payment for stories, pictures or information, which seek to exploit a particular crime or to glorify or glamorise crime in general, must not be made directly or via agents to convicted or confessed criminals or to their associates – who may include family, friends and colleagues.
- (ii) Editors invoking the public interest to justify payment or offers would need to demonstrate that there was good reason to believe the public interest would be served. If, despite payment, no public interest emerged, then the material should not be published.

## NOTES

### The public Interest

There may be exceptions to the clauses marked ‘\*’ where they can be demonstrated to be in the public interest.

1. The public interest includes, but is not confined to:
  - (i) Detecting or exposing crime or serious impropriety.
  - (ii) Protecting public health and safety.
  - (iii) Preventing the public from being misled by an action or statement of an individual or organisations.
2. There is a public interest in freedom of expression itself.
3. Whenever the public interest is invoked, the PCC will require editors to demonstrate fully that they reasonably believed that publication, or journalistic activity undertaken with a view to publication, would be in the public interest.
4. The PCC will consider the extent to which material is already in the public domain, or will become so.
5. In cases involving children under 16, editors must demonstrate an exceptional public interest to over-ride the normally paramount interest of the child.

#### 6.3.1 A Code of Ethics for the Indian Press

In 1992, the Council brought out ‘A Guide to Journalistic Ethics’. An updated version of the code was published in 1996.

#### Principles and Ethics

The fundamental objective of journalism is to serve the people with news, views, comments and information on matters of public interest in a fair, accurate, unbiased, sober and decent manner. Towards this end, the Press is expected to conduct itself in keeping with certain norms of professionalism universally recognized. The norms enunciated below and other specific guidelines appended thereafter, when applied with due discernment and adaptation to the varying circumstance of each case, will help the journalist to self-regulate his or her conduct.

#### Accuracy & Fairness

1. The Press shall eschew publication of inaccurate, baseless, graceless, misleading or distorted material. All sides of the core issue or subject should be reported. Unjustified rumours and surmises should not be set forth as facts.

#### Pre-publication Verification

2. On receipt of a report or article of public interest and benefit containing imputations or comments against a citizen, the editor should check with due

care and attention its factual accuracy-apart from other authentic sources with the person or the organisation concerned to elicit his/her or its version, comments or reaction and publish the same with due amendments in the report where necessary. In the event of lack or absence of response, a footnote to that effect should be appended to the report.

## **NOTES**

### **Caution against defamatory writings**

3. Newspaper should not publish anything which is manifestly defamatory or libelous against any individual organization unless after due care and checking, they have sufficient reason to believe that it is true and its publication will be for public good.
4. Truth is no defence for publishing derogatory, scurrilous and defamatory material against a private citizen where no public interest is involved.
5. No personal remarks which may be considered or construed to be derogatory in nature against a dead person should be published except in rare cases of public interest, as the dead person cannot possibly contradict or deny those remarks.
6. The Press shall not rely on objectionable past behaviour of a citizen for basing the scathing comments with reference to fresh action of that person. If public good requires such reference, the Press should make pre-publication inquiries from the authorities concerned about the follow up action, if any, in regard to those adverse actions.
7. The Press has a duty, discretion and right to serve the public interest by drawing reader's attention to citizens of doubtful antecedents and of questionable character but as responsible journalists they should observe due restraint and caution in hazarding their own opinion or conclusion in branding these persons as 'cheats' or 'killers' etc. The cardinal principle being that the guilt of a person should be established by proof of facts alleged and not by proof of the bad character of the accused. In the zest to expose, the Press should not exceed the limits of ethical caution and fair comments.
8. Where the impugned publication are manifestly injurious to the reputation of the complainant, the onus shall be on the respondent to show that they were true or to establish that they constituted for comment made in good faith and for public good.  
  
Parameters of the right of the Press to comment on the acts and conduct of public officials.
9. So far as the government, local authority and other organs/institutions exercising governmental power are concerned, they cannot maintain a suit for damages for acts and conduct relevant to the discharge of their official duties unless the official establishes that the publication was made with reckless

## NOTES

disregard for the truth. However, judiciary which is protected by the power to punish for contempt of court and the Parliament and Legislatures, protected as their privileges are by Articles 105 and 194 respectively, of the Constitution of India, represent exception to this rule.

10. Publication of news or comments/information on public officials conducting investigations should have a tendency to help the commission of offences or to impede the prevention or detection of offences or prosecution of the guilty. The investigative agency is also under a corresponding obligation not to leak out or disclose such information or indulge in disinformation.
11. The Official Secrets Act, 1923 or any other similar enactment or provision having the force of law equally bind the press or media though there is no law empowering the state or its officials to prohibit, or to impose a prior restraint upon the Press/media.
12. Cartoons and caricatures in depicting good humour are to be placed in a special category of news that enjoy more liberal attitude.

### **Right to Privacy**

13. The Press shall not intrude or invade the privacy of an individual unless outweighed by genuine overriding public interest, not being a prurient or morbid curiosity. So, however, that once a matter becomes a matter of public record, the right to privacy no longer subsists and it becomes a legitimate subject for comment by Press and media among others.

Explanation: Things concerning a person's home, family, religion, health, sexuality, personal life and private affairs are covered by the concept of PRIVACY excepting where any of these impinges upon the public or public interest.

14. Caution against identification: While reporting crime involving rape, abduction or kidnap of women/females or sexual assault on children, or raising doubts and questions touching the chastity, personal character and privacy of women, the names, photographs of the victims or other particulars leading to their identity shall not be published.
15. Minor children and infants who are the offspring of sexual abuse or 'forcible marriage' or illicit sexual union shall not be identified or photographed.

### **Recording interviews and phone conversation**

16. The Press shall not tape-record anyone's conversation without that person's knowledge or consent, except where the recording is necessary to protect the journalist in a legal action, or for other compelling good reason.
17. The Press shall, prior to publication, delete offensive epithets used by an interviewer in conversation with the Press person.

18. Intrusion through photography into moments of personal grief shall be avoided. However, photography of victims of accidents or natural calamity may be in larger public interest.

### **Conjecture, comment and fact**

19. Newspaper should not pass on or elevate conjecture, speculation or comment as a statement of fact. All these categories should be distinctly stated.

### **Newspapers to eschew suggestive guilt**

20. Newspapers should eschew suggestive guilt by association. They should not name or identify the family or relatives or associates of a person convicted or accused of a crime, when they are totally innocent and a reference to them is not relevant to the matter reported.
21. It is contrary to the norms of journalism for a paper to identify itself with and project the case of any one party in the case of any controversy/dispute.

### **Corrections**

22. When any factual error or mistake is detected or confirmed, the newspaper should publish the correction promptly with due prominence and with apology or expression of regrets in a case of serious lapse.

### **Right of Reply**

23. The newspaper should promptly and with due prominence, publish either in full or with due editing, free of cost, at the instance of the person affected or feeling aggrieved/or concerned by the impugned publication, a contradiction/reply/clarification or rejoinder sent to the editor in the form of a letter or note. If the editor doubts the truth or factual accuracy of the contradiction/reply/clarification or rejoinder, he shall be at liberty to add separately at the end a brief editorial comment doubting its veracity, but only when this doubt is reasonably founded on unimpeachable documentary or other evidential material in his/her possession. This is a concession which has to be availed of sparingly with due discretion and caution in appropriate cases.
24. However, where the reply/contradiction or rejoinder is being published in compliance with the discretion of the Press Council, it is permissible to append a brief editorial note to that effect.
25. Right of rejoinder cannot be claimed through the medium of Press Conference, as publication of the news of a conference is within the discretionary powers of an editor.
26. Freedom of the Press involves the readers' right to know all sides of an issue of public interest. An editor, therefore, shall not refuse to publish the reply or rejoinder merely on the ground that in his opinion the story published

### **NOTES**

in the newspaper was true. That is an issue to be left to the judgement of the readers. It also does not behove an editor to show contempt towards a reader.

## **NOTES**

### **Letters to Editor**

27. An editor who decides to open his columns for letters on a controversial subject is not obliged to publish all the letters received in regard to that subject. He is entitled to select and publish only some of them either in entirety or the gist thereof. However, in exercising this discretion, he must make an honest endeavour to ensure that what is published is not one-sided but represents a fair balance between the views for and against with respect to the principal issue in controversy.
28. In the event of rejoinder upon rejoinder being sent by two parties on a controversial subject, the editor has the discretion to decide at which stage to close the continuing column.

### **Obscenity and vulgarity to be eschewed**

29. Newspapers/journalists shall not publish anything which is obscene, vulgar or offensive to public good taste.
30. Newspapers shall not display advertisements which are vulgar or which, through depiction of a woman in nude or lewd posture, provoke lecherous attention of males as if she herself was a commercial commodity for sale.
31. Whether a picture is obscene or not, is to be judged in relation to three tests; namely
  - (i) Is it vulgar and indecent?
  - (ii) Is it a piece of mere pornography?
  - (iii) Is its publication meant merely to make money by titillating the sex feelings of adolescents and among whom it is intended to circulate? In other words, does it constitute an unwholesome exploitation for commercial gain?

Other relevant considerations are whether the picture is relevant to the subject matter of the magazine. That is to say, whether its publication serves any preponderating social or public purpose, in relation to art, painting, medicine, research or reform of sex.

### **Violence not to be glorified**

32. Newspapers/journalists shall avoid presenting acts of violence, armed robberies and terrorist activities in a manner that glorifies the perpetrators acts, declarations or death in the eyes of the public.



### **Glorification/encouragement of social evils to be eschewed**

33. Newspapers shall not allow their columns to be misused for writings which have a tendency to encourage or glorify social evils like Sati Pratha or ostentatious celebrations.

### **Covering communal disputes/clashes**

34. News, views or comments relating to communal or religious disputes/clashes shall be published after proper verification of facts and presented with due caution and restraint in a manner which is conducive to the creation of an atmosphere congenial to communal harmony, amity and peace. Sensational, provocative and alarming headlines are to be avoided. Acts of communal violence or vandalism shall be reported in a manner as may not undermine the people's confidence in the law and order machinery of the State. Giving community-wise figures of the victims of communal riot, or writing about the incident in a style which is likely to inflame passions, aggravate the tension, or accentuate the strained relations between the communities/religious groups concerned, or which has a potential to exacerbate the trouble, shall be avoided.

### **Headings not to be sensational/provocative and must justify the matter printed under them**

35. In general and particularly in the context of communal disputes or clashes—
  - a. Provocative and sensational headlines are to be avoided;
  - b. Headings must reflect and justify the matter printed under them;
  - c. Headings containing allegations made in statements should either identify the body or the source making it or at least carry quotation marks.

### **Caste, religion or community references**

36. In general, the caste identification of a person or a particular class should be avoided, particularly when in the context it conveys a sense or attributes a conduct or practice derogatory to that caste.
37. Newspapers are advised against the use of word 'Scheduled Caste' or 'Harijan' which has been objected to by some persons.
38. An accused or a victim shall not be described by his caste or community when the same does not have anything to do with the offence or the crime and plays no part either in the identification of any accused or proceeding, if there be any.
39. Newspaper should not publish any fictional literature distorting and portraying the religious characters in an adverse light transgression of the norms of literary taste and offending the religious susceptibilities of large sections of

### **NOTES**

## NOTES

society who hold those characters in high esteem, invested with attributes of the virtuous and lofty.

40. Commercial exploitation of the name of prophets, seers or deities is repugnant to journalistic ethics and good taste.

### **Reporting on natural calamities**

41. Facts and data relating to spread of epidemics or natural calamities shall be checked up thoroughly from authentic sources and then published with due restraint in a manner bereft of sensationalism, exaggeration, surmises or unverified facts.

### **Paramount national interest**

42. Newspapers shall, as a matter of self-regulation, exercise due restraint and caution in presenting any news, comment or information which is likely to jeopardise, endanger or harm the paramount interests of the State and society, or the rights of individuals with respect to which reasonable restrictions may be imposed by law on the right to freedom of speech and expression under clause (2) of Article 19 of the Constitution of India.
43. Publication of wrong/incorrect map is a very serious offence, whatever the reason, as it adversely affects the territorial integrity of the country and warrants prompt and prominent retraction with regrets.

### **Newspapers may expose misuse of diplomatic immunity**

44. The media shall make every possible effort to build bridges of co-operation, friendly relations and better understanding between India and foreign States. At the same time, it is the duty of a newspaper to expose any misuse or undue advantage of the diplomatic immunities.

### **Investigative journalism, its norms and parameters**

45. Investigative reporting has three basic elements:
- a. It has to be the work of the reporter, not of others he is reporting;
  - b. The subject should be of public importance for the reader to know;
  - c. An attempt is being made to hide the truth from the people.
    - (i) The first norm follows as a necessary corollary from (a) that the investigative reporter should, as a rule, base his story on facts investigated, detected and verified by himself and not on hearsay or on derivative evidence collected by a third party, not checked up from direct, authentic sources by the reporter himself.
    - (ii) There being a conflict between the factors which require openness and those which necessitate secrecy, the investigative journalist should strike and maintain in his report a proper balance between

openness on the one hand and secrecy on the other, placing the public good above everything.

- (iii) The investigative journalist should resist the temptation of quickies or quick gains conjured up from half-baked incomplete, doubtful facts, not fully checked up and verified from authentic sources by the reporter himself.
- (iv) Imaginary facts, or ferreting out or conjecturing the non-existent should be scrupulously avoided. Facts and yet more facts are vital and they should be checked and cross-checked whenever possible until the moment the paper goes to Press.
- (v) The newspaper must adopt strict standards of fairness and accuracy of facts. Findings should be presented in an objective manner, without exaggerating or distorting, that would stand up in a court of law, if necessary.
- (vi) The reporter must not approach the matter or the issue under investigation, in a manner as though he were the prosecutor or counsel for the prosecution. The reporter's approach should be fair, accurate and balanced. All facts properly checked up, both for and against the core issues, should be distinctly and separately stated, free from any one-sided inferences or unfair comments. The tone and tenor of the report and its language should be sober, decent and dignified, and not needlessly offensive, barbed, derisive or castigatory, particularly while commenting on the version of the person whose alleged activity or misconduct is being investigated. Nor should the investigative reporter conduct the proceedings and pronounce his verdict of guilt or innocence against the person whose alleged criminal acts and conduct were investigated, in a manner as if he were a court trying the accused.
- (vii) In all proceedings including the investigation, presentation and publication of the report, the investigative journalist newspaper should be guided by the paramount principle of criminal jurisprudence, that a person is innocent unless the offence alleged against him is proved beyond doubt by independent, reliable evidence.
- (viii) The private life, even of a public figure, is his own. Exposition or invasion of his personal privacy or private life is not permissible unless there is clear evidence that the wrong doings in question have a reasonable nexus with the misuse of his public position or power and has an adverse impact on public interest.
- (ix) Though the legal provisions of Criminal Procedure do not in terms, apply to investigating proceedings by a journalist, the fundamental principles underlying them can be adopted as a guide on grounds of equity, ethics and good conscience.

## NOTES

**NOTES**

**Confidence to be respected**

46. If information is received from a confidential source, the confidence should be respected. The journalist cannot be compelled by the Press Council to disclose such source; but it shall not be regarded as a breach of journalistic ethics if the source is voluntarily disclosed in proceedings before the Council by the journalist who considers it necessary to repel effectively a charge against him/her. This rule requiring a newspaper not to publish matters disclosed to it in confidence, is not applicable where:

- (a) consent of the source is subsequently obtained; or
- (b) the editor clarified by way of an appropriate footnote that since the publication of certain matters were in the public interest, the information in question was being published although it had been made 'off the record'.

**Caution in criticizing judicial acts**

47. Excepting where the court sits 'in-camera' or directs otherwise, it is open to a newspaper to report pending judicial proceedings in a fair, accurate and reasonable manner. But it shall not publish anything:—

- which, in its direct and immediate effect, creates a substantial risk of obstructing, impeding or prejudicing seriously the due administration of justice; or
- is in the nature of a running commentary or debate, or records the paper's own findings, conjectures, reflection or comments on issues, subjudice and which may amount to arrogation to the newspaper the functions of the court; or
- regarding the personal character of the accused standing trial on a charge of committing a crime.

Newspaper shall not as a matter of caution, publish or comment on evidence collected as a result of investigative journalism, when, after the accused is arrested and charged, the court becomes seized of the case: Nor should they reveal, comment upon or evaluate a confession allegedly made by the accused.

48. While newspapers may, in the public interest, make reasonable criticism of a judicial act or the judgement of a court for public good; they shall not cast scurrilous aspersions on, or impute improper motives, or personal bias to the judge. Nor shall they scandalize the court or the judiciary as a whole, or make personal allegations of lack of ability or integrity against a judge.

49. Newspaper shall, as a matter of caution, avoid unfair and unwarranted criticism which, by innuendo, attributes to a judge extraneous consideration for performing an act in due course of his/her judicial functions, even if such criticism does not strictly amount to criminal Contempt of Court.

### **Newspapers to avoid crass commercialism**

50. While newspapers are entitled to ensure, improve or strengthen their financial viability by all legitimate means, the Press shall not engage in crass commercialism or unseemly cut-throat commercial competition with their rivals in a manner repugnant to high professional standards and good taste.
51. Predatory price wars/trade competition among newspapers, laced with tones disparaging the products of each other, initiated and carried on in print, assume the colour of unfair 'trade' practice, repugnant to journalistic ethics. The question as when it assumes such an unethical character, is one of the fact depending on the circumstances of each case.

### **Plagiarism**

52. Using or passing off the writings or ideas of another as one's own, without crediting the source, is an offence against ethics of journalism.

### **Unauthorized lifting of news**

53. The practice of lifting news from other newspapers publishing them subsequently as their own, ill-comports the high standards of journalism. To remove its unethicity the 'lifting' newspaper must duly acknowledge the source the report. The position of feature articles is different from 'news': Feature articles shall not be lifted without permission proper acknowledgement.
54. The Press shall not reproduce in any form offending portions or excerpts from a proscribed book.

### **Non-return of unsolicited material**

55. A paper is not bound to return unsolicited material sent for consideration of publication. However, when the same is accompanied by stamped envelope, the paper should make all efforts to return it.

### **Advertisements**

56. Commercial advertisements are information as much as social, economic or political information. What is more, advertisements shape attitude and ways of life at least as much, as other kinds of information and comment. Journalistic propriety demands that advertisements must be clearly distinguishable from editorial matters carried in the newspaper.
57. Newspaper shall not publish anything which has a tendency to malign wholesale or hurt the religious sentiments of any community or section of society.
58. Advertisements which offend the provisions of the Drugs and Magical Remedies (Objectionable Advertisement) Act, 1954, should be rejected.

## **NOTES**

## NOTES

59. Newspapers should not publish an advertisement containing anything which is unlawful or illegal, or is contrary to good taste or to journalistic ethics or proprieties.
60. Newspapers while publishing advertisements shall specify the amount received by them. The rationale behind this is that advertisements should be charged at rates usually chargeable by a newspaper since payment of more than the normal rates would amount to a subsidy to the paper.
61. Publication of dummy advertisements that have neither been paid for, nor authorised by the advertisers, constitute breach of journalistic ethics.
62. Deliberate failure to publish an advertisement in all the copies of a newspaper offends against the standards of journalistic ethics and constitutes gross professional misconduct.
63. There should be no lack of vigilance or a communication gap between the advertisement department and the editorial department of a newspaper in the matter of considering the propriety or otherwise of an advertisement received for publication.
64. The editors should insist on their right to have the final say in the acceptance or rejection of advertisements, especially those which border on or cross the line between decency and obscenity.
65. An editor shall be responsible for all matters, including advertisements published in the newspaper. If responsibility is disclaimed, this shall be explicitly stated beforehand.

### Check Your Progress

3. When was the American Society of Newspaper Editors founded?
4. What does the editor's code have to say related to accuracy?
5. According to the code, when can the press identify victims of sexual assault?
6. What are the three elements of investigative reporting?

---

## 6.4 ANSWERS TO CHECK YOUR PROGRESS QUESTIONS

---

1. Convergent journalism is the name given to multitasking in journalism where a journalist is expected to not only produce a report for the newspaper, he is also required to give it orally for radio and/or television and at the same time give a brief one for mobile news services as well.
2. Gonzo journalism is a form of journalism that is popularized by the American writer Hunter S. Thompson.

3. The American Society of Newspaper Editors was founded in 1922.
4. According to the editor's code, the Press must take care not to publish inaccurate, misleading or distorted information, including pictures. A significant inaccuracy, misleading statement or distortion once recognised must be corrected, promptly and with due prominence, and - where appropriate - an apology published.
5. According to the code, the press must not identify victims of sexual assault or publish material likely to contribute to such identification unless there is adequate justification and they are legally free to do so.
6. Investigative reporting has three basic elements:
  - a. It has to be the work of the reporter, not of others he is reporting;
  - b. The subject should be of public importance for the reader to know;
  - c. An attempt is being made to hide the truth from the people.

## NOTES

---

### 6.5 SUMMARY

---

- Today, the competitive markets have posed many responsibilities and the nature and work of journalists have changed.
- On the one hand, we find big conglomerates pumping huge amount of money in different media technologies and on the other hand there are people with relatively smaller capital investing on media.
- Convergent journalism is the name given to multitasking in journalism where a journalist is expected to not only produce a report for the newspaper, he is also required to give it orally for radio and/or television and at the same time give a brief one for mobile news services as well.
- Fashion journalism comprises the reports and articles on the fashion world. The journalists in this field are also called as fashion editors or fashion writers.
- Though sports belong to entertainment category, sports journalism is one of the most important aspects of journalism. For reporting sports events, the journalist should have proper knowledge of the game including points, rules and regulations etc.
- Ambush journalism connotes the aggressive tactics taken up by the journalists to abruptly confront and question the individuals who would otherwise not speak to the media. Particularly the television journalists have taken the practice on a large scale.
- Generally there are causes of dissatisfaction and complaints against journalists. People feel that they are biased, they are not truthful or they take sides.
- Journalist associations and many other bodies such as press councils have evolved certain guidelines for the journalists. Over the years, there have

## NOTES

been various codes of ethics agreed and endorsed by the journalists and editors.

- Freedom of the press is to be guarded as a vital right of mankind. It is the unquestionable right to discuss whatever is not explicitly forbidden by law, including the wisdom of any restrictive statute.
- A newspaper should not publish unofficial charges affecting reputation or moral character without opportunity given to the accused to be heard; right practice demands the giving of such opportunity in all cases of serious accusation outside judicial proceedings.
- The press must avoid prejudicial or pejorative reference to an individual's race, colour, religion, gender, sexual orientation or to any physical or mental illness or disability.
- The fundamental objective of journalism is to serve the people with news, views, comments and information on matters of public interest in a fair, accurate, unbiased, sober and decent manner.
- The newspaper should promptly and with due prominence, publish either in full or with due editing, free of cost, at the instance of the person affected or feeling aggrieved/or concerned by the impugned publication, a contradiction/reply/clarification or rejoinder sent to the editor in the form of a letter or note.
- There should be no lack of vigilance or a communication gap between the advertisement department and the editorial department of a newspaper in the matter of considering the propriety or otherwise of an advertisement received for publication.

---

## 6.6 KEY WORDS

---

- **Accuracy:** It means the quality of correctness as to fact and precision as to detail in information resources and in the delivery of news or information services.
- **Convergence:** It means the use of different media for the delivery of news and current affairs programme.
- **Bias:** It means the tendency in a news report to deviate from an accurate, neutral, balanced and impartial representation of the 'reality' of events and social world according to stated criteria.
- **Objectivity:** It means judgement based on observable phenomena and uninfluenced by emotions or personal prejudices.
- **Gonzo Journalism:** It is a style of journalism that is written without claims of objectivity, often including the reporter as part of the story via a first-person narrative.



---

## 6.7 SELF ASSESSMENT QUESTIONS AND EXERCISES

---

### Short-Answer Questions

1. Write a short-note on online journalism.
2. What is citizen journalism?
3. What is the editors' code as it relates to harassment?
4. How is the Indian press expected to cover communal and caste clashes?

### Long-Answer Questions

1. Describe canons of journalism as described by Yost.
2. Examine the code of journalistic ethics provided by the Indian Press Council.
3. What do you understand by the 'canons of journalism'? Describe the different parameters set up by the American Society of Newspaper Editors.
4. Describe the basic constituents of ethical standards set up by the International Federation of Journalists (IFJ).

---

## 6.8 FURTHER READINGS

---

- Mcquail, Denis. 2013. *Journalism and Society*. New Delhi: Sage Publications.
- Bro, Peter. 2018. *Models of Journalism: The Functions and Influencing Factors*. London: Routledge.
- Burns, Lynette Sheridan. 2002. *Understanding Journalism*. New Delhi: Sage Publications.
- Raghavan, G.N.S. 1994. *Press in India: A New History*. New Delhi: Gyan Publishing House.
- Sharma, K. Suresh. 2006. *Press in India*. New Delhi: Vista International Publishing House.
- Parthasarathy, Rangaswami. 1984. *Basic Journalism*. New Delhi: Macmillan India Limited.

### NOTES

NOTES

---

## UNIT 7 OVERVIEW OF PRESS COMMISSIONS AND COMMITTEES

---

### Structure

- 7.0 Introduction
- 7.1 Objectives
- 7.2 Press Commissions and Committees
  - 7.2.1 First Press Commission
  - 7.2.2 Second Press Commission
- 7.3 Answers to Check Your Progress Questions
- 7.4 Summary
- 7.5 Key Words
- 7.6 Self Assessment Questions and Exercises
- 7.7 Further Readings

---

### 7.0 INTRODUCTION

---

In the previous unit, you learnt about the codes and ethics in journalism. In this unit, the discussion will turn towards the press commissions that have been established in independent India.

To evaluate the exact condition of press in India, the First Press Commission was appointed in September 1952. Its chairman was Justice G.S. Rajadhyaksha. In its report submitted in 1954, the Commission made many significant recommendations which resulted in the setting up of a number of institutions. These institutions were meant to organize the profession of journalism in a systematic way. It was the first enquiry of this nature looking into the functioning of press. The Second Press Commission was established in 1978 and gave rise to the Press Council in India. The Commission also argued for a 'cordial relationship between the government and the press'. The commission resigned and later another second press commission was established in 1980.

---

### 7.1 OBJECTIVES

---

After going through this unit, you will be able to:

- Describe the recommendations of the First Press Commission
- Discuss the Second Press Commission

---

## 7.2 PRESS COMMISSIONS AND COMMITTEES

---

The press played a key role in the Indian freedom struggle. From time to time, the British Government enforced legal provisions to control the press. Leaders of freedom struggle like Mahatma Gandhi and Bal Gangadhar Tilak were working as newspaper editors as well and hence were sent to jail for their writings. Just before Independence, the Interim Government formed the Press Law Enquiry Committee to study the existing laws in relation to fundamental rights.

### NOTES

#### 7.2.1 First Press Commission

To study the status of the press as well as suggest measures for its healthy growth in independent India, the first Press Commission was constituted on 23 September 1952. Justice G.S. Rajadhyaksha was its chairman with very renowned persons serving as the members. The Commission gave its report in 1954.

Apart from legal provisions concerned with press, the Commission looked into the management, control, ownership and financial structure of the press. It also studied the content and working environment and service conditions prevailing in the sector. For example, the commission observed the decline in the editor's position:

There has been a general decline in the status and independence of the editor and this decline is particularly noticeable in the case of daily newspapers. In the past it was quite usual for the majority of the readers to be both aware and conscious of the role played by the editor in the formulation of the views set out in the paper, and it was quite usual to refer to the paper not merely by its name but by the name of the editor. The position has changed today and we feel that the bulk of the newspaper readers today may be unaware of who is the editor of their newspaper and indifferent to the name that appears on small print on the last page.

The Commission criticized the practice of giving astrological predictions and stated: 'The spread of the habit of consultation of, and reliance upon, astrological predictions, particularly of the nature and manner they are published at present is certain to produce an unsettling effect on the minds of readers. We would describe the practice of publishing such predictions as undesirable.'

The Commission took a serious note of the occurrence of yellow journalism, slanderous writing directed against groups or communities, sensationalism, prejudice in presenting news and lack of proper responsibility in comment, indecent remarks and crudeness and personal attacks on individuals. Nonetheless, the Commission observed that the well-established newspapers had, more or less, preserved a high journalistic standard. They had been successful in avoiding 'cheap sensationalism and unwarranted intrusion into private lives'. However, it stated that 'whatever the law relating to the Press may be, there would still be a large quantum of objectionable journalism which, though not falling within the purview

## NOTES

of the law, would still require to be checked'. It held the opinion that the most suitable manner of sustaining professional journalistic standards is to set up a body of individuals mainly related to the industry. This body should be accountable to arbitrate on doubtful points and to reprimand anyone found guilty of the breach of the code of journalistic ethics.

In this connection the Commission stated the need for the establishment of a Press Council:

- (a) to safeguard the freedom of the press and help the press to maintain its independence.
- (b) to censure objectionable types of journalistic conduct and by all other possible means to build up a code in accordance with the highest professional standards.
- (c) to keep under review any development likely to restrict the supply and dissemination of news of public interest and importance.
- (d) to encourage the growth of a sense of responsibility and of public service among those engaged in the profession of journalism.
- (e) to study the developments in the press which may tend towards concentration or monopoly, and if necessary, to suggest remedies.
- (f) to publish reports, at least once a year, recording its work and reviewing the performance of the press, its development and factors affecting them and
- (g) to improve methods of recruitment, education and training for the profession by the creation of suitable agencies for the purpose such as a Press Institute.

The Commission emphasized the need for establishing the Council on a statutory basis. It noted that the Council should possess legal authority to hold inquiries or else each member, and the Council as a whole, will be subject to the danger of legal action by those whom it seeks to punish.

The Commission observed that the Council should comprise men who command the respect and confidence of the profession. It should possess twenty-five members excluding the Chairman. The Chairman, to be nominated by the Chief Justice of India, must be an individual who was or had been a Judge of the High Court. On 4 July 1966, the press council of India was established and it began functioning from 16 November 1966. This day is commemorated as the National Press Day.

The Office of the Registrar of Newspapers for India (RNI) also owes its existence to the First Press Commission's recommendations. The Commission observed: 'To prepare the account of the press and the position of every year, there should be appointment of the Registrar of Newspaper for India (RNI).'

After a detailed and careful study, the Commission concluded that both capital and the staff should be indigenized, particularly at the higher levels. Further,

it was very much expected that the proprietorial interests in daily and weekly newspapers are chiefly controlled by the Indians themselves.

After evaluating the Press Commission's recommendations and the Note provided by the Ministry of Information & Broadcasting, the Union Cabinet adopted a Resolution on 13 September 1955. It became the fundamental policy document regarding the functioning of press in India. The resolution banned Foreign Direct Investment in print media.

Concerned about the poor service conditions of working journalists, the Commission made detailed recommendations to improve them. In 1955, the Government enacted the Working Journalist and Other Newspaper Employees (Conditions of Services) and Miscellaneous Provisions Act. Under this Act, Wage Boards were appointed. The Commission also suggested that there needs to be a relationship between price and pages. It is necessary to control excessive advertising in some newspapers. The government accepted this recommendation for a Price-Page Schedule. However, the Supreme Court of India struck it down.

Many members of the Commission were freedom fighters like those in the Government, so the Commission was in favour of 'maintaining a cordial relationship between the government and the Press'. To meet this end, it recommended the setting up of a Press Consultative Committee. Consequently, a Press Consultative Committee was set up on 22 September 1962.

To assess the financial condition of the newspapers and news agencies, the Commission recommended the establishment of a fact-finding committee. As a result, a Fact Finding Committee was set up on 14 April 1972, which gave its report on 14 January 1975.

To protect the key principles of the freedom of press and to save the newspapers from monopolistic trends, the Commission suggested the formation of Newspaper Financial Corporation. On 4 December 1970, a Bill was presented in the Lok Sabha to this effect, but unfortunately it lapsed.

The Commission also recommended that a public corporation needs to run the Press Trust of India. This recommendation was not heeded to at that time. However, during the Internal Emergency this idea was revived and after the merger of four news agencies, 'Samachar' was formed. However, it was undone by the Janata Government.

### **7.2.2 Second Press Commission**

The atmosphere in the country had changed when the Second Press Commission was appointed. The Internal Emergency had come to an end with Mrs. Indira Gandhi losing in the General Elections of 1977. After coming to power, the Janata Government appointed the Second Press Commission on 29 May 1978. Justice P.K. Goswami was its chairman. However, before the Commission could give its report, the Janata Government fell bringing elections to the Lok Sabha in its wake. In these elections, Mrs Indira Gandhi recaptured power. The Goswami Commission

## **NOTES**

## NOTES

resigned on 14 January 1980. Anyway, the Second Press Commission was revived in April 1980 with Justice K.K. Mathew as its chairman. Its members included Amrita Pritam, Rajendra Mathur, Girilal Jain, K.R. Ganesh and Madan Bhatia.

The Second Press Commission expected the press to be neither a mechanical opponent nor an automatic ally of the government. It wanted the press to play a significant role in the development process in the country. ‘The press should be widely accessible to the people if it is to reflect their aspirations and problems.’

The issue of urban bias also drew the attention of the Commission. It stated that for development to take place, internal stability was must to safeguard the national security. The Commission further highlighted the role and responsibility of the press in preventing communal disturbances. Moreover, the Commission maintained that development has to be the essential focus of the press. The Commission observed that a responsible press may also be a free press and vice-versa. It held that freedom and responsibility are complimentary to each other instead of being contradictory in nature.

The Commission further recommended the concept of Price-page schedule believing that the Supreme Court might revise its earlier verdict. To ensure the development and growth of small and medium newspapers, the Commission recommended the setting up of Newspaper Development Commission. It also wished that newspapers need to be separated from industries and other business interests.

Over all, the Second Press Commission’s report provides a decent overview of the development of press since the report of First Press Commission. Many studies and researches were commissioned by the Commission to study various aspects of the press. All this has created a big pool of information which is very useful for the researchers. Unfortunately, unlike the First Press Commission, the institutions and authorities recommended by the Second Press Commission could not come into existence. Also, it was not able to give any specific direction to the press, because most of the media houses ignored its recommendations.

There have been demands for setting up a media commission since the turn of present century because media scene has undergone massive changes since the Second Press Commission gave its report. Nonetheless, so far no new commission is in sight of getting constituted.

### Check Your Progress

1. Who was the chairman of the First Press Commission?
2. When is National Press Day celebrated?
3. When was the Second Press Commission revived?

---

### **7.3 ANSWERS TO CHECK YOUR PROGRESS QUESTIONS**

---

1. Justice G.S. Rajadhyaksha was the chairman of the First Press Commission with very renowned persons serving as the members.
2. On 4 July 1966, the press council of India was established and it began functioning from 16 November 1966. This day is commemorated as the National Press Day.
3. The Second Press Commission was revived in April 1980 with Justice K.K. Mathew as its chairman.

### **NOTES**

---

### **7.4 SUMMARY**

---

- The press played a key role in the Indian freedom struggle. From time to time, the British Government enforced legal provisions to control the press.
- Just before Independence, the Interim Government formed the Press Law Enquiry Committee to study the existing laws in relation to fundamental rights.
- To study the status of the press as well as suggest measures for its healthy growth in independent India, the first Press Commission was constituted on 23 September 1952.
- Apart from legal provisions concerned with press, the Commission looked into the management, control, ownership and financial structure of the press.
- The Commission took a serious note of the occurrence of yellow journalism, slanderous writing directed against groups or communities, sensationalism, prejudice in presenting news and lack of proper responsibility in comment, indecent remarks and crudeness and personal attacks on individuals.
- The Commission emphasized the need for establishing the Council on a statutory basis. It noted that the Council should possess legal authority to hold inquiries or else each member, and the Council as a whole, will be subject to the danger of legal action by those whom it seeks to punish.
- The Second Press Commission was revived in April 1980 with Justice K.K. Mathew as its chairman. Its members included Amrita Pritam, Rajendra Mathur, Girilal Jain, K.R. Ganesh and Madan Bhatia.
- The Second Press Commission expected the press to be neither a mechanical opponent nor an automatic ally of the government. It wanted the press to play a significant role in the development process in the country.
- The Second Press Commission's report provides a decent overview of the development of press since the report of First Press Commission.

## NOTES

---

### 7.5 KEY WORDS

---

- **Fundamental Rights:** These are defined as the basic human rights of all citizens. These rights, defined in Part III of the Constitution, applied irrespective of race, place of birth, religion, caste, creed, or gender.
- **Press Council:** It is a body established to raise and maintain professional standards among journalists.
- **Foreign Direct Investment:** It is an investment in the form of a controlling ownership in a business in one country by an entity based in another country.

---

### 7.6 SELF ASSESSMENT QUESTIONS AND EXERCISES

---

#### Short-Answer Questions

1. What was the remit of the First Press Commission?
2. Write a short-note on the Second Press Commission.

#### Long-Answer Questions

1. Describe what the First Press Commission had to say regarding the need to establish a press council.
2. Explain the recommendations of the First Press Commission.

---

### 7.7 FURTHER READINGS

---

- Mcquail, Denis. 2013. *Journalism and Society*. New Delhi: Sage Publications.
- Bro, Peter. 2018. *Models of Journalism: The Functions and Influencing Factors*. London: Routledge.
- Burns, Lynette Sheridan. 2002. *Understanding Journalism*. New Delhi: Sage Publications.
- Raghavan, G.N.S. 1994. *Press in India: A New History*. New Delhi: Gyan Publishing House.
- Sharma, K. Suresh. 2006. *Press in India*. New Delhi: Vista International Publishing House.
- Parthasarathy, Rangaswami. 1984. *Basic Journalism*. New Delhi: Macmillan India Limited.



---

## UNIT 8 REPORTS OF MEDIA COMMITTEES

---

### NOTES

#### Structure

- 8.0 Introduction
- 8.1 Objectives
- 8.2 Chanda Committee
  - 8.2.1 Joshi Committee
- 8.3 Verghese Committee
- 8.4 Karanth Working Group
- 8.5 Answers to Check Your Progress Questions
- 8.6 Summary
- 8.7 Key Words
- 8.8 Self Assessment Questions and Exercises
- 8.9 Further Readings

---

### 8.0 INTRODUCTION

---

In the previous unit, you learnt about the reports of the first and second press commissions. In this unit, the discussion will turn towards various media committee reports.

In independent India, the first media committee report was set up by the then Information & Broadcasting Minister Indira Gandhi in 1964. The committee was led by former Auditor-General of India Ashok Chanda and its remit was to investigate Indian broadcasting. The committee presented a report on radio and television in 1966 that was critical of the state's financial and administrative restrictions on these media. According to Canadian professor of media and development studies Robin Jeffrey, 'The timing of the report – April 1966 – was inopportune. The Prime Minister, Lal Bahadur Shastri, had died in January, Mrs Gandhi was an unsteady replacement, the country had just fought its second war in three years and the two-year Bihar famine was beginning.' The Chanda committee recommended that *Âkâshvânî* and *Doordarshan* be separated, something that finally came into being a decade later, in 1976. The debate about the political independence of the public broadcasters was resumed in 1977 with the Verghese Committee. These reports, along with some others, are discussed briefly taken up in this unit.

---

### 8.1 OBJECTIVES

---

After going through this unit, you will be able to:

- Discuss the Joshi and Verghese committee reports
- Describe the report of the Chanda committee

## NOTES

---

## 8.2 CHANDA COMMITTEE

---

When Mrs Indira Gandhi joined the Union Cabinet for the first time in 1964 as Minister of Information and Broadcasting, she set up an inquiry committee for improving *All India Radio* (AIR). The committee came to be known as the Chanda Committee as it was headed by A.K. Chanda, a former Comptroller and Auditor-General of India. The report was submitted in 1966. The committee proposed three recommendations which were:

- to convert AIR into a corporation run by a Board of Governors like the BBC
- to separate television from radio and commercialize Vividh Bharati channel so that there is increase in the revenue of All India Radio
- the revenue earned should be utilized for improving the quality of AIR's programmes

Only the last recommendation was accepted by the Government at that time which led to the beginning of commercial broadcasting in India on 1 November 1967. Later, TV (*Doordarshan*) was separated from AIR in 1976.

### 8.2.1 Joshi Committee

The committee headed by P.C. Joshi was established to study the software of *Doordarshan*. The committee recommended changes in the organizational setup of radio and television. The government at that time was not ready to alter the structure and the recommendations were not acted upon.

#### Check Your Progress

1. Why was the Chanda Committee set up?
2. Why was the Joshi Committee established?

---

## 8.3 VERGHESE COMMITTEE

---

In 1977, the Janata Party was swept to power displacing Mrs Gandhi's Congress Party government. Since the Janata Party in its poll manifesto had promised to give autonomy to AIR and *Doordarshan*, on assuming office, it set up a Working Group in August 1977 under the chairmanship of George Verghese, a noted journalist, to work out the proposals for giving full autonomy to AIR and *Doordarshan*. The working group submitted its report entitled 'Akash Bharati' in two volumes in February 1978. However, rejecting the group's recommendations for full autonomy, the then Minister for Information and Broadcasting, L.K. Advani, piloted a bill in Parliament which was called the Prasar Bharati. This was introduced

in the Lok Sabha on December 1989, but, because of the sudden dissolution of the then Lok Sabha, the bill lapsed. Finally in 1990, the Prasar Bharati Bill with several amendments was passed by Parliament. However the successive Governments decided not to finalize the Act. It took another 7 years for the implementation of the 'Prasar Bharati Act.'

Between 1978 and 1997, a number of committees examined the working of Radio and Television in the country. Just as there were complaints of misuse of the media during the emergency, there were complaints of the politicization of the media during the post emergency era. When Mrs Gandhi came back to power after the fall of the Janata Government, the Government constituted a committee under the chairmanship of eminent journalist and diplomat G. Parthasarathi. This committee which had equally eminent members drew specific policy guidelines for the first time for the electronic media. It presented exhaustive guidelines for the news producers and also defined the approach to external broadcasting. The government accepted the recommendation of the committee.

## NOTES

---

### 8.4 KARANTH WORKING GROUP

---

A 'Working Group on National Film Policy' was established by the Government of India led by the Janata Party on the recommendation of a Conference of State Ministers of Information in 1979. K. Shivarama Karanth. Kannada writer, educationist and *Yaksha Gana* specialist was appointed as the Chairman of the working group. Among the members of his Working Group were Mrinal Sen, Shyam Benegal, Basu Bhattacharya. Adoor Gopalakrishnan, Ramanand Sagar and Manoj Kumar, Tarun Mazumdar (film-makers). Tarachand Barjatya and D.V.S. Raju (film producers). Dilip Jamadar (documentary film-maker), Vijaya Mulay (formerly of the Censor Board) and others. The Report of the Working Group is by far the most comprehensive and need-based report, compiled so far in the history of India's cinema industry. The report was submitted its report in 1980, when Indira Gandhi had already returned to power.

The Karanth Working Group report criticised both the government's ability to overrule Central Board of Film Certification (CBFC) decision-making and the political appointment of CBFC members. According to the scholar William Mazzarella, the Karanth Working Report is exemplary of a circular governmental logic that repeatedly justifies Indian censorship: 'ensorious, repressive governments and a lack of education have kept the masses immature...further censorship is necessary in order to protect these illiterate unfortunates from their own worst instincts.' The Report named both the U.K. and U.S. classification systems in its consideration of the Indian approach and noted the challenges posed for both parents and censors by the separation between the two extreme categories of 'U and 'A'. In its recommendation for an intermediary certificate Karanth Working Group report stressed that it would be 'purely advisory' and that 'Ideally the

## NOTES

decision as to whether a certified film may or may not be seen by children should rest with the parents'. It also recommended the introduction of a 'Q', or Quality, certificate, which if granted would exempt the film from entertainment and other taxes. The report stated, 'We feel a separate committee attached to the Censor Board consisting primarily of film makers, film critics and people from allied arts should recommend the grant of quality certificate.'

### Check Your Progress

3. What was the name of the report of the Verghese committee?
4. When was the Karanth Working Group established?

---

## 8.5 ANSWERS TO CHECK YOUR PROGRESS QUESTIONS

---

1. When Mrs Indira Gandhi joined the Union Cabinet for the first time in 1964 as Minister of Information and Broadcasting, she set up an inquiry committee for improving All India Radio (AIR). The committee came to be known as the Chanda Committee.
2. The committee headed by P.C. Joshi was established to study the software of Doordarshan.
3. The Verghese committee submitted its report entitled 'Akash Bharati' in two volumes in February 1978.
4. The Karanth Working Group was established by the Government of India led by the Janata Party on the recommendation of a Conference of State Ministers of Information in 1979.

---

## 8.6 SUMMARY

---

- When Mrs Indira Gandhi joined the Union Cabinet for the first time in 1964 as Minister of Information and Broadcasting, she set up an inquiry committee for improving All India Radio (AIR).
- The committee came to be known as the Chanda Committee as it was headed by A.K. Chanda, a former Comptroller and Auditor-General of India.
- One of the recommendations of the Chanda Committee report was that the revenue earned should be utilized for improving the quality of AIR's programmes.

- The committee headed by P.C. Joshi was established to study the software of Doordarshan. The committee recommended changes in the organizational setup of radio and television.
- Since the Janata Party in its poll manifesto had promised to give autonomy to AIR and Doordarshan, on assuming office, it set up a Working Group in August 1977 under the chairmanship of George Verghese, a noted journalist, to work out the proposals for giving full autonomy to AIR and Doordarshan.
- When Mrs Gandhi came back to power after the fall of the Janata Government, the Government constituted a committee under the chairmanship of eminent journalist and diplomat G. Parthasarathi. This committee which had equally eminent members drew specific policy guidelines for the first time for the electronic media.
- A 'Working Group on National Film Policy' was established by the Government of India led by the Janata Party on the recommendation of a Conference of State Ministers of Information in 1979.
- K. Shivarama Karanth. Kannada writer, educationist and Yaksha Gana specialist was appointed as the Chairman of the working group.
- The Karanth Working Group report criticised both the government's ability to overrule Central Board of Film Certification (CBFC) decision-making and the political appointment of CBFC members.
- In its recommendation for an intermediary certificate Karanth Working Group report stressed that it would be 'purely advisory' and that 'Ideally the decision as to whether a certified film may or may not be seen by children should rest with the parents'.
- The Karanth Working Group also recommended the introduction of a 'Q', or Quality, certificate, which if granted would exempt the film from entertainment and other taxes.

## NOTES

---

### 8.7 KEY WORDS

---

- **Censorship:** It refers to the suppression or prohibition of any parts of books, films, news, etc. that are considered obscene, politically unacceptable, or a threat to security.
- **Emergency:** Generally speaking, it means a period where fundamental rights in India are suspended due to a grave or dangerous situation. Specifically, it refers to the period of 1975-1977 when fundamental rights had been suspended by the central government.
- **Diplomat:** It means an official whose job is to represent one country in another, and who usually works in an embassy.

---

## 8.8 SELF ASSESSMENT QUESTIONS AND EXERCISES

---

### NOTES

#### Short-Answer Questions

1. What were the recommendations of the Chanda Committee?
2. Write a short-note on the Joshi Committee.

#### Long-Answer Questions

1. Discuss the Verghese Committee and its recommendations.
2. Describe the Karanth Working Group report.

---

## 8.9 FURTHER READINGS

---

- Mcquail, Denis. 2013. *Journalism and Society*. New Delhi: Sage Publications.
- Bro, Peter. 2018. *Models of Journalism: The Functions and Influencing Factors*. London: Routledge.
- Burns, Lynette Sheridan. 2002. *Understanding Journalism*. New Delhi: Sage Publications.
- Raghavan, G.N.S. 1994. *Press in India: A New History*. New Delhi: Gyan Publishing House.
- Sharma, K. Suresh. 2006. *Press in India*. New Delhi: Vista International Publishing House.
- Parthasarathy, Rangaswami. 1984. *Basic Journalism*. New Delhi: Macmillan India Limited.

---

**BLOCK - III**  
**MEDIA AND ITS FUNCTIONS AND TYPES**

---

*Mass Communication  
Media*

---

**UNIT 9 MASS COMMUNICATION  
MEDIA**

---

**NOTES**

**Structure**

- 9.0 Introduction
- 9.1 Objectives
- 9.2 Media for Mass Communication
- 9.3 Print Media
- 9.4 Electronic Media
- 9.5 Radio
- 9.6 Television
  - 9.6.1 Cinema
- 9.7 New Media
- 9.8 Answers to Check Your Progress Questions
- 9.9 Summary
- 9.10 Key Words
- 9.11 Self Assessment Questions and Exercises
- 9.12 Further Readings

---

**9.0 INTRODUCTION**

---

In the previous unit, you learnt about the reports of various media committees. The present unit is meant to give you an overview of the different tools of media that facilitate the process of mass communication.

Mass communication is one of the central activities of modern society. It is possible for the people to communicate with each other at the interpersonal level with the help of language in the form of speech, but one cannot communicate with masses without using other types of media such as print, radio, films, television and the most recent of them the 'new media'. In this unit, a brief history and evolution of these media along with the strength, weaknesses and impact is discussed with an objective of giving a comprehensive picture of these media and their use and utility in the process of mass communication. The unit involves discussion on various types of mass media along with their genres with which people construct their messages.

## NOTES

---

### 9.1 OBJECTIVES

---

After going through this unit, you will be able to:

- Describe the various media of mass communication
- Discuss the origin and growth of different media
- Describe the different genres or types of the mass media
- Evaluate the use and impact of these media in mass communication
- Relate the various media of mass communication with the process of mass communication

---

### 9.2 MEDIA FOR MASS COMMUNICATION

---

The main feature of mass communication is that people are heterogeneous and scattered all over the world. The role of mass media in mass communication is to disseminate information to all the people in the world at a single point of time.

As we have seen in the earlier units, speech is the primary media of communication and all other media are merely extension of speech. However, it is important to understand the difference between media of communication and media of mass communication. Telephone, gramophone, photographs, postcards and letters are some of the main media of communication. They allow communication between individuals. They mostly involve one-to-one communication.

Mass communication is also defined as one-to-many type of communication. It requires certain type of media that allows one-to-many communication. Radio, cinema, print, television and the Internet are the technologies of media that make mass communication possible.

Print has allowed the circulation of manuscripts at the mass level whereas radio has extended the scope of human speech. Cinema came to our rescue by giving us moving images that were identical to the reality around us. Television helped us in sending the live events and realities in real time. Internet in one sense is not like the mass media such as radio, television and cinema as these technologies are invented to send a message from the source to all the possible readers, listeners and viewers.

---

### 9.3 PRINT MEDIA

---

Print can be defined as a medium that disseminates writing or textual matter. Printing is defined as a process that involves the use of ink, paper and a printing press for reproducing text and image. The technology of printing using a printing press allows a large-scale production of the same matter. Printing is a technique that is an integral part of publishing.



Printing has covered a long journey starting from wooden block printing that was in practice in China and Korea much before Johann Gutenberg designed movable types made of molten metal alloy and a printing press in the mid-fifteenth century. Lots of efforts were made by him to cast the right type of letters, developing the right type of ink that he made from lamp black mixed in an oil-based varnish and combining together all these important components for the use of printing. It is said that it took him almost 20 years to bring this system into practice. His system is considered as the first revolution in printing technology.

The second revolution in printing technology came at the end of the 19th century. Two methods of mechanical typesetting were invented that speeded up the process of setting the type in metal. They were monotype system and line casting. The third revolution was phototypesetting. Finally, Desktop Publishing (DTP) is considered the fourth revolution in printing. The DTP system has brought dramatic changes in the printing industry. Presently it is a widely accepted system in printing.

The most recent and the most revolutionary invention in the field of printing technology is that of desktop publishing. It is a new way to create a print document in less time and at less cost. Linked with the Internet technology of data transfer, it has given a new lease of life to the newspapers in this age of faster communication like television and online journalism.

### **Genres of Print Medium**

The emergence of print medium has been a big achievement of the human species as it has not only allowed it to store and disseminate the knowledge, it has also allowed us to communicate in numerous ways in print. Books were the very first form that were printed and distributed; afterwards the periodicals came which soon gave place to newspapers. People used print for pamphlets and handbills for advertising and political propaganda. Magazines in weekly, fortnightly, monthly and bimonthly periodicity found their way at a later stage.

In this section of the unit, we will look at various genres of print to understand its power and reach.

### **Books**

Everyone would agree that books are an invaluable source of Knowledge. As we have seen earlier, books were present even before printing was invented, but they used to be in the form of manuscript. Books provided people to think individually and involve in discourses that would have been difficult in speech. In that way we can say that books not only stored the human knowledge but they also paved the way for the development of knowledge.

There are many types of books and each one really teaches us to look at that particular book in a different way. The books can be commonly classified according to their content. They are broadly either fiction or non-fiction. However, by no means the books are limited to this classification only.

## **NOTES**

## NOTES

### ***Fiction***

Many of the books published today are fictitious stories. They are in-part or completely untrue or fantasy. Historically, paper production was considered too expensive to be used for entertainment. An increase in global literacy and print technology led to the increased publication of books for the purpose of entertainment, and on many social issues that are allegorically called social commentary.

The most common form of fictional book is called the ‘novel’ that contains stories that typically feature a plot, themes and characters. Stories and narrative are not restricted to any topic. In a way we can say that the modern literature would not have benefitted with this and other genre if the technology of printing a book was not there. There are comic books in which the story is not told, but illustrated.

### ***Non-fiction***

There are reference books that provide information as opposed to telling a story, essay, commentary or otherwise supporting a point of view. An ‘encyclopaedia’ is a book or set of books designed to have more in-depth articles on many topics. A more specific reference book with tables or lists of data and information about a certain topic, often intended for professional use, is often called a ‘handbook’.

There are books with technical information on how to do something or how to use some equipment. There are textbooks that help the students in their studies in various disciplines.

There are several other types of books which deal with various subjects in various formats and have different objectives. There are books on photography having a major part of the content as photographs whereas ‘the Life and Time publications’ series of books on various topics like forests, marine life, automobile, architecture, etc., have so many visuals along with the text that it gives an entirely different experience of reading books.

### **Periodicals**

A periodical is a published text that appears on a regular interval of time. It can be a weekly, monthly, bimonthly, quarterly or an annual. In early years almost all newspapers were like periodicals. Even now, some small newspapers published from various small towns and remote areas can technically be considered as periodicals as they are not published daily, though they are called newspapers. Some examples of periodicals are newsletters, magazines, journals and annual reports. There are some exceptions as far as their naming is considered, for instance, *The Wall Street Journal* is actually a newspaper and not a journal.

The first issue of the periodical *Review* was published in London in 1704. This periodical of four pages was like a weekly newspaper, yet it was different from the early newspapers as it focused on the articles on domestic and national

policies. Daniel Foe, the founder of *Review* edited the first issue from the New Gate prison where he was kept for his critical views on certain policies of the Church of England.

With the growth of industry and various market trends, the taste and needs of the masses have changed in recent years. Publishers understand their market. Hence, today we see a variety of magazines on automobiles, home decoration, real estates, mobiles, computers, etc.

Magazines are also available on the Internet. They are known as online magazines. They share some features with blogs and also with online newspapers. The online magazines that are a part of the World Wide Web are called 'webzines'. The suffix 'ezine' here refers to 'their distribution carried out electronically' where 'zine' is an abbreviation of the word magazine.

Though magazines are also kept and preserved in libraries along with other books, but there was a time when people collected and preserved the issues of their favourite magazines at their homes. The knowledge and information in them never exhausts with the change of time.

### **Newspapers**

A newspaper is also a periodical. It publishes at regular intervals. Reports, articles, editorials, features, notices, advertisements, cartoons and photos are some of its contents. It is printed on a low-grade paper that is not expensive and it is known as newsprint.

A newspaper covers a variety of topics. There are some newspapers that concentrate on a specific topic, for instance, a business newspaper covers all the information regarding business and economy and issues that affect the business or are essential for business. A newspaper of general interest caters to the needs of everyone by covering stories on national, international and regional political as well as social events. It also informs us on business, crime, sports, literature, fashion, films and other entertainments like puzzles, comic strips and features on food, places, personalities and fine arts. Weather reports, forecasts and horoscopes are other attractive features of a newspaper.

A newspaper is known by its editorial writing. In fact, the editorial page reflects the policies and ideology of a newspaper. Editorial page contains editorials written by the editor or by the editorial team on current issues, articles by guest writers expressing their opinions on certain issues and a letters to the editor column.

Newspapers can be categorized on the basis of their periodicity. A daily newspaper is issued everyday and a weekly newspaper appears once a week. Weekly newspapers are usually small newspapers appearing from districts or small towns. They depend on mainstream major papers for their contents on international and national issues. Newspapers can be further categorized into three types according to their size. They are broadsheet, tabloid and quarto-size newspapers. The normal size newspapers like *The Hindu* and *The Times of India* are known as

### **NOTES**

## NOTES

broadsheet newspapers. The tabloid newspapers are small in character. Generally, the special supplements of big newspapers are published in tabloid forms. The small and medium newspapers are generally tabloid size newspapers. The quarto-size newspapers are one-fourth of the broadsheet newspapers. They are not in existence now days.

During the last decades due to the growing markets, newspapers have become more colourful with a bundle of advertisements and celebrity news. Most of the newspapers are coming with various types of supplements to cater to the needs of various sections of the society and also to keep up with the recent trend of value addition.

### Posters

A piece of printed paper that is clipped to community boards, pasted on walls or simply hung on the doors and trees is known as 'poster'. A poster includes textual as well as graphic information. Some varieties of posters are completely graphical or textual representations.

Generally they are designed to attract the attention of the masses. Hence they are attractive, colourful and eye-catching. They are used in propaganda, protests, advertising or simply inform people about any event.

From the earlier times people have been using posters in various forms like placards and poster bills. We see agitators holding in their hands placards in rallies or even at airports one can see people holding placards with the name of the person written on it, they are looking for. We often see in the markets or in our colonies some information regarding sale, or tuitions printed on a piece of paper and pasted on the walls. This is also a form of poster that is used for advertising purpose.

Advertising posters are used for films, books or event promotions and also for inviting audiences for music and dance recitals and pop shows. Till recently Bollywood film posters were in high demand by the producers. Posters are also used for academic purposes in promoting and explaining the theme of seminars and conferences. Posters are being widely used in protecting environment, saving wildlife, and maintaining peace and harmony in the world.

### Pamphlets

UNESCO's Institute of Statistics defines a 'pamphlet' as a non-periodic printed publication of at least 49 pages exclusive of the cover pages. A pamphlet is an unbound booklet. It does not have a hard cover. It may consist of a single sheet of paper, printed on both sides and folded usually in half. According to the volume of the matter and size of the paper, it may be folded in thirds or in fourths. It contains the information about a product or service.

When we buy an electric appliance, medicines, computers or mobiles, we get a folded sheet of paper mentioning on it 'how to use' instructions. This is a

pamphlet. Actually pamphlets play a very important role in marketing business. They do not require much money in their production and can be distributed easily to customers. They can be used in political campaigning. They are also referred as leaflets.

### **Flyers**

Flyers or handbills are single-page unfolded leaflets usually meant for advertising services or products. They can be used by individuals in promoting their business, product, services or any special cause. Flyers can be handed to people in shopping complexes. They are cost-effective and are considered as a very reliable form of direct marketing or advertising. We get a variety of flyers in the morning kept in between the folds of newspapers—they may be simple, colourful, printed on coarse, dull or glossy paper, small or large.

### **Brochures**

A brochure is a type of pamphlet or leaflet. It can be a single sheet or can have multi-sheets. In the latter case, it is stapled on the creased edge. A brochure uses high quality paper; it is more colourful and is folded. It contains information and sometimes photos or graphics as well. Theatres circulate brochures amongst their audiences before the play or concert starts, mentioning the castings and details of the programme. Hospitals and hotels offer brochures to their visitors informing them about their services.

Brochures are often printed on glossy paper. Professional and high-quality brochures are produced using in-design, quarks express and adobe illustrator. There are various types of brochures like sales brochures, corporate brochures, travel, company and marketing brochures.

### **Print as a Medium**

The print has made a lasting impact on the societies. The print media has had the privilege to be on the scene for more than three centuries as the sole media of mass communication. It has seen many types of revolution and has reported them as newspapers. It has been and still is the biggest reservoir of the knowledge accumulated over many centuries in the form of books.

In fact many scholars say that it was the written medium along with the print that has allowed human beings to indulge with the spirit of experimentation that alone is responsible for the development of science and technology. They say so because the writing makes us use our hands while the speech never allowed us to do that.

It was only because of the print that we could discover the new ways of telling the stories. The novel as the form of literature could not have existed if the art of printing would not have allowed us to deal with the narratives of reality at such lengths. We learnt many different ways of expressing us with the help of print

### **NOTES**

## NOTES

medium. The pamphlets, posters, newspapers and magazines and reference books are all made possible by the printing technology.

The contribution of print to democracy is enormous as everyone today would acknowledge that the newspapers and magazines are the lifeline of the modern democratic societies. They help people to become conscious citizens and empower them to debate and discuss various issues concerning them.

### Check Your Progress

1. What is the role of mass media in mass communication?
2. What is a poster?
3. What is a brochure?

---

## 9.4 ELECTRONIC MEDIA

---

Electronic media helps the students to understand different aspects of communication by the means of audio, visual and audio-visual media. Communication has metamorphosed into a high-end technical art with the passage of time. Technological advancement has been a catalyst in this metamorphosis. Various types of media, namely, print, mass electronic as well as news media are the areas that have gained momentum in recent years.

Mass media are social media that contribute towards not only building strong nations but also spreading a feeling of unity through transmission of values and norms in messages. Mass media can facilitate successful socialization of individuals. They have the ability to mobilize people by spreading a single message to a large audience. Messages conveyed through mass media can reach people who are spread far and wide almost instantly. Let us analyse the importance of electronic media especially with reference to the field of development in our country.

1. **Radio:** All India Radio or AIR as it is popularly known started with only six broadcasting stations in 1947. By 1997 there were 155 radio stations, and the number has been increasing since then. Now, with the privatization of air waves, private FM radio has managed to make its presence felt very strongly in the country. In fact, even today radio remains the most popular means of infotainment for the rural masses and for those who are always on the run. In 1956, the rural forums that were conducted in association with UNESCO became highly popular in Pune.
2. **Television:** Television was introduced in the country in 1959 but its usage was very restricted. The television network in India was programmed, strengthened and established with the combined efforts of UNESCO, the US, Germany, Japan and Yugoslavia. Today India is

the world's second largest cable connected country. Today, programmes are telecast 24x7 on Indian television.

Satellite Instructional Television Experiment (SITE) is considered to be one of the biggest techno-social communication experiments in education and rural development. The one-year experiment (August 1975 – July 1976) aimed to provide direct broadcasting of instructional and educational television in 2400 villages in the states of Andhra Pradesh, Bihar, Karnataka, Madhya Pradesh, Orissa and Rajasthan. Over 500 conventional television sets spread over 335 villages in Kheda district, Gujarat was also part of SITE. Satellite technologists had referred to SITE as a giant leap from the bullock cart stage to satellite communication without discriminating between the rural poor and the urban rich in issues related to information and communication. It had given 50 years of communication lead to the rural poor of the country. SITE telecasts were specifically aimed at rural primary school teachers as well as students in the age group of 5–12 years studying in grades 1–5. Rural adults preferred watching television programmes that provided them information on improved agricultural practices, health and family planning. They were also able to view news. Television was considered as the window to the world. The telecast reliability was above 99 per cent during the experiment period.

3. **Internet:** Technological advances have made information a basic resource. By the beginning of the 21st century, the US had more people working in the production of information than in the manufacturing or agriculture industry. This led to the advent of the concept of 'information society'. India has caught up very fast and is today one of the world leaders to have created enterprises centred around information technology. The closing decade of the twentieth century was the opening of historic information and communication technology interventions for development. This period was witness to enormous and unprecedented changes in every aspect of communication technologies, policies, infrastructure development and services. Indian political leaders opted to give up the outdated practice of government control over communication. The same has moved from the hands of the government to national and international private players.

The different media such as films, radio and television have been discussed in detail subsequently in this unit.

#### Check Your Progress

4. When was television introduced in India?
5. What was SITE?

#### NOTES

## NOTES

---

### 9.5 RADIO

---

The emergence of radio in Europe after a long stretch of their dependence on print changed the human behaviour to a large extent. It has been described as ‘tribal drum because the radio had socked the European people who had learned to divide the world in public and private spaces’.

The need for rapid long-distance communication led to the invention of the radio. Mid-nineteenth century was a period where long-distance communication technologies were coming one after other. The first was the election dot and dash telegraph in 1844 by F.B. Morse. The technology of telephone in 1876, wireless telegraph in 1896 and the concept of radio telephony got materialized in 1906. All this become possible as the science was already there. Michael Faraday was doing experiment on magnetic fields. Another scientist Maxwell predicted that electromagnetic energy could be sent at the speed of light. He proved the existence of radio waves in the decade of 1860 and a little later a German physicist Heinrich Rudolph Hertz found that the fast moving electric current could be projected into the space.

It was Sir J.C. Bose, an Indian, who had invented radio in 1876, but he could not patent it due to lack of knowledge about patents. But Marconi successfully sent radio signals in 1895, and patented the radio in 1896. Thus, Marconi became the official inventor of radio.

#### Medium Wave and Shortwave

Let us try to understand how this technology of receiving voice in the radio sets kept at our homes was made possible. Radio communication uses electromagnetic waves to transfer information, in our case voice, from one point to another. Our voice frequencies range from 50 Hz to 3000 Hz. The basic principle of radio communication involves conversion of such voice frequencies to a higher frequency then radiating them through an antenna and at the receiver end again converting the electromagnetic radiations to voice frequencies. Transmitters and receivers are required to propagate and intercept radio waves. Radio waves carry the information or signals. This information is encoded directly on the wave by interrupting its transmission or it is impressed on it by a process known as modulation. When at the receiver end these electromagnetic radiations are converted back to voice frequencies, the process is known as demodulation.

Amplitude modulation is the older method of broadcasting, and it is still in use. We already know that AM radio was started with the broadcast on the eve of 1906 by Canadian scientist Reginald Fessenden. During winters the AM broadcast band is more favourable as the nights are lengthy and have longer dark hours.

The AM radio technology is a simpler broadcasting on several frequency bands. It gets disrupted by manmade or atmospheric interferences. Hence, it is



not well suited for music programmes but all over the world is used in the programmes of news, talks, sports, etc.

Medium waves (MW) signals have a typical characteristic of following the curvature of the earth at all times. They are also refracted off the ionosphere at night. Hence this frequency band is ideal for local as well as continent-wide services. This happens because AM signals get disrupted in large urban areas by metal structures, tall buildings, lightning and atmospheric noise. Medium wave is a radio wave with a wavelength between 100 and 1000 meters. Basically it is a frequency between 300–3000 KHz.

Shortwave (SW) is a high frequency between 3000–30,000 KHz. The wavelengths in this band are shorter. The SW radio is used for long-distance communications. It can easily be transmitted over a distance of several thousands of kilometers. In tropical regions, SW is less disrupted by thunderstorms than medium wave radio and thus can cover a larger geographic area. But overcrowding on the wavebands, atmospheric disturbances and electrical interferences from appliances and installations disturb the broadcast. In such cases, the delivered voice quality is poor at times. Even otherwise, the audio quality of shortwave broadcast is inferior in comparison to the MW though the SW frequencies can reach any location on the earth.

It was the shortwave that made it possible for us to listen to BBC, Voice of America, Deutsche Welle and broadcasts from all over the world. Similarly, the External Services Division of All India Radio uses the shortwave to broadcast its programmes in various foreign languages to the concerned countries. Shortwave transmissions were of great importance to us from the very beginning. It brought events to the listeners from other countries. Germany and Soviet Union started to broadcast internationally in the 1920s. The Voice of America and the BBC also broadcast in various languages.

### **FM Radio**

From the early days of radio transmissions, scientists were bothered by the hissing noises caused by the atmospheric electricity. They made great efforts to reduce this but the problem was not solved completely. Edwin Armstrong in 1933 developed a new kind of radio signal based on frequency modulation. Frequency modulation is a method of conveying information over a carrier wave by varying its frequency. This is different from AM in which the amplitude of the carrier wave is varied while its frequency remains constant. Since this system is static, free and can carry much higher or lower frequencies, it proves to be an ideal carrier of music. The reach of the FM is only up to the horizon hence the broadcast is limited to a specific area only.

Armstrong used a much broader bandwidth than the AM stations. By doing this, he gave not only hissing-free reception but also much higher audio quality than provided by the AM radio. Frequency band to FM radio is about 88–108

### **NOTES**

## NOTES

MHz. The FM Radio is broadcast in stereo that means it has two channels of information. The FM system rejects the noise better than the AM system. Noise is spread across the wide spectrum. The amplitude of the noise varies quite randomly at these frequencies. The AM system picks up any change in amplitude that changes the signal. Hence, AM is resistive to noise while FM is not. That is the reason why FM is able to provide interference-free reception and a high audio quality.

### **Satellite Radio, XM and Podcasting**

Satellite radio is a digital radio signal. It is the latest in digital radio technology. It is relayed through satellites hence can be received in a much wider geographical area than the terrestrial AM and FM radio. Satellite radio services are subscription based and they are provided by commercial companies. Satellite radio is one of the fastest growing entertainment services in the world.

At present there are two space-based radio broadcasters namely WorldSpace and Sirius XM radio. These companies have merged into a single company but the two services are not fully integrated yet.

The ground station transmits a signal to GEO satellites. These signals are reflected back by the satellites to radio receivers on the ground. Radio receivers receive and unscramble the digital data signal which contains more than 170 channels of digital audio. These signals contain encoded sound and information about the broadcast that include the title of the song, artist's name and genre of music to be displayed on the radio.

Podcasting is a service that allows the Internet users to pull audio files from a podcasting website to listen to various programmes on their computers or on personal digital audio players. Podcasting is the combination of Podium and casting. MTV jockey Adam Curry and software developer Dave Winer jointly developed podcasting in 2004. Curry downloaded the Internet radio broadcasts to his ipod with the help of a programme called ipodder. Though podcasting is almost free of cost, some of the international companies are eyeing it for making profits. In Australia, podcast network runs commercials during its audio programmes. The radio stations like the National Public Radio, the Canadian Broadcasting Corporation and the BBC also podcast their programmes.

Very soon the use of podcasting technology will not be limited to just music alone; it will be a useful tool in the field of education as well. Podcasting in India is at an initial stage. Despite the fact that there are approximately 3,000 Indian podcasters, podcasting is not a very popular venture. One of the podcasters is Sunil Gavaskar who hosted a cricket podcast at Yahoo India. Some of the podcasts in Indian languages are *podmasti*, *podbharti* and *podbazar*. The XM Satellite Radio (XM) is one of two satellite radio (SDARS) services in the United States and Canada, operated by Sirius XM Radio.

## Radio as a Medium of Communication

Radio is a useful and powerful instrument for mass communication. In developing countries like India, radio is an important mass media. As more than 30 per cent of the people are illiterate, radio caters the information and entertainment needs of the people as they cannot read the newspapers. Further, for disseminating the development messages, radio is the most effective medium.

It has certain drawbacks and advantages as an audio medium. It is capable of disseminating information at distances and in a very wide area very quickly. Messages and information can be delivered the moment they are received. Unlike television it does not require special arrangements for the broadcast. A radio reporter can be prompter than a TV reporter thus making radio more reliable for broadcasting the event or happenings and is certainly a faster medium than the print.

As an audio medium its reach is quite comprehensive. It delivers the messages that are heard and comprehended by all from highly educated intellectuals to neo-literates as well as to illiterates. It is a different fact altogether that though each individual receives the same message, he/she may interpret it differently.

Radio is cost effective as well. It runs on electricity for which charges are nominal. Even battery-operated radio sets or transistors are not expensive as the batteries are not very costly. Now a day, people are able to access FM radio on their mobile phones as well.

Radio is a boon for differently able persons who cannot see as they can listen to the news, enjoy music and make themselves aware of the world which they cannot see. Even for normal people it enhances their visualizing and imaginative powers. Properly framed and well-spoken sentences for a particular situation create a similar picture of the situation in the minds of listeners giving them the opportunity to visualize it. For this, writing skills and good speech play a very important role. It applies to every radio programme, be it a programme of news and current affairs, a docudrama or a feature.

When people for the first time heard the explosions of bombs during the World War II they came to believe what disaster was brought by the war and what it did to the lives of hundreds of people in the city. They believed in the authenticity of the radio that brought the war close to them.

Radio does not captivate its listeners. They can receive messages, enjoy music or feature while they are working. A busy executive may also listen to a current affairs programme while driving, a student can listen to important announcement and news while getting ready for his college, a farmer may listen to agriculture or music during his work in the field. Radio does not snatch time from one's working schedule.

## NOTES

## NOTES

When people are engaged in listening, most of the information gets registered and recorded in their minds. As there is no distraction while listening to radio programme, the information is retained in their minds and they have opportunity to think about it as well. Thus, radio helps in developing our thinking ability and in shaping our attitudes.

Keeping in mind the impact and strength of radio, the Government of India launched several projects in the field of education, healthcare, agriculture, etc. They were school broadcast (1937), adult education and community development (1956), farm and home broadcast (1966), university broadcast (1965), etc.

Today the radio has become interactive and has started live broadcast too where people can participate by sharing their views on topics that are discussed. Almost all services of All India Radio offer live participation of audiences. The FM radio stations are much ahead in this regard. People can inform the FM station about various happenings and events they witness while the programme is on air. For instance, the events like road accident, traffic jams, sudden fall in temperature or rains in a particular area, storms, etc. Thus, people could associate themselves more with radio. They found themselves participating in the programme which was certainly exciting. This technique also increases the listenership which is good for radio channels for their survival by getting more sponsors.

Some governments have provided aid or sponsored programmes on education, agriculture, health, women empowerment, etc. But this is not sufficient. More guidelines and more schemes and formats have to be checked out to bring remote population close to each other to work for issues like hunger, poverty, unemployment and so on. Masses should just not enjoy being on air and talking rubbish and irrelevant things; they must come forward with new innovation and constructive ideas to fight against these problems.

---

## 9.6 TELEVISION

---

Television has been the most spectacular invention of the 20th century. It has not only made it possible to view the events and happenings of the world instantly, it has brought the cinema in the form of soap operas and telefilms and even in its usual form to the drawing rooms of the people. It has become the most accessed media and very powerful tool for forming opinions as well. Many politicians have been able to capture and maintain their political power with the help of television. Some of these people own television networks not only in Europe and Latin America but in India as well.

In 1884, a German Scientist Paul Nipkow experimented with a rotating disk containing small holes and found that this device can work as a scanner. The disk, known as Nipkow disc, produced patterns of electric impulses required to transmit pictures. This device became an integral part of the technology of transmitting images. Even today, this scanning concept is a standard component of

the television. After Paul Nipkow's technology, it is J.L. Baird who invented television in 1926.

The television industry grew further with the growth of cable television and with adoption of video cassette recorders. Cable television system was needed in those areas that were not getting the proper signals because of geographical as well as manmade conditions. Tall buildings, densely populated areas and valleys or hills blocked television signals. As a result, television transmitter could not receive them. Initially setting up of cable system was started on a low scale but when it was found that the picture quality is good, the cable operators jumped in for making profit.

The beginning of the 1970s was the period when Video Cassette Recorder (VCR) was adopted all over the world for recording the programmes of one's choice from the TV network. It was also a very useful device for editing. The VCR was invented in America by Ampex Corporation. Charles Ginsberg designed this machine to record television programmes on a magnetic tape. Japan improved the technology by standardizing the systems and became the number one manufacturer and exporter of video cassette recorder. The VCRs became more popular for movie viewing. Movies were recorded on the VCRs and cassettes were sold in the markets or at book stalls. The tape technology of the VCRs gave rise to digital storage technology where any programme can be squeezed on a compact disk.

The Russians launched Sputnik, the world's first satellite on 4 October 1957. A few months later, the United States launched Explorer I on 1 January 1958. In 1976, history was created by Home Box Office (HBO) by starting satellite delivery of programming to cable networks with the telecast of 'The Thriller from Manila', a heavyweight boxing match. The match was played between Joe Frazier and Mohammed Ali. With the growth of satellite broadcasting, people looked to the multi-channel facilities with low price, as an alternative to cable.

Satellite system provides clear pictures and stereo sound on various channels. Conceptually, satellite system is a wireless system that delivers television programming directly to the viewers. Satellite TV systems transmit and receive radio signals using satellite dishes. These dishes act like antennas. Earlier the size of the uplink dishes was quite huge as much as 9 to 12 meters in diameter. Satellites are placed in geosynchronous orbits. They stay in one place in the sky relative to the earth. Each one is approximately 22,200 miles or 35,700 kms above the earth.

The first ever satellite TV signal was sent from Europe to the Telstar Satellite in 1962. The first geosynchronous communication satellite Syncom 2 was launched in 1963 and Intelsat I, the first commercial communication satellite was launched in 1965. Intelsat I is also called 'Early Bird'. Soviet Union was the first to start national network of Satellite Television which was named 'Orbita' and was deployed in 1967.

## NOTES

## NOTES

All over the world, the satellite TV is growing rapidly in the recent years. The television is migrating from analogue to digital where audio and video are transmitted by discrete signals. The use of digital signals is allowing other uses of radio spectrum. This has been made possible with the advent of broadband. The advanced broadband technology allows consumer to combine video, phone and data services with an access to the Internet. The most significant advantage of such a system is that digital channels are accommodated in less bandwidth. This allows more channels to flow in the same space. Digital system provides high definition TV service with better picture, better sound and multimedia service with feedback and talkback facility. Digital signals react differently to interference and obstacles. The common problems faced in analogue TV were ghosting of images, noise, and less clear or sometime wavy picture quality. But in digital technology audio and video are synchronized digitally hence providing a crystal clear reception. It is a system of storing, processing and transmitting information through the use of distinct electronic pulses that represent the binary digits 0 and 1. In analogue system, the sound of the broadcast is modulated separately from the video. Analogue is a transmission standard that uses electrical impulses to emulate the audio waveform of sound.

### Television in India

Television in India appeared on 15 September 1959. It was started as an experiment to train personnel and to find out its possibilities in the field of community development and education. UNESCO granted a sum of \$20,000 and offered the required equipments to make this experiment possible. In the beginning, 180 community teleclubs benefitted from the programmes that were telecast twice a week, each of 20 minutes duration. The range of the transmitters was just 40 kilometres. After two years in 1961 it was found that the programmes had some impact on the audiences. As a result, educational programmes on science for the teachers were started in 1961.

Programmes on entertainment and information were introduced from August 1965. Next important step was the introduction of the programmes on agriculture. With the help of the Department of Atomic Energy, the Indian Agriculture Research Institute, Delhi Administration and the State Governments of Haryana and Uttar Pradesh, a programme named 'Krishi Darshan' was started for the farmers. The range of the transmitters was now increased up to 60 kilometres.

By 1975 there were four television centres in the cities like Mumbai, Srinagar, Amritsar and Pune (relay centre). Under Satellite Instructional Television Experiment Scheme, six states were selected for the transmission of educational programmes. This project lasted from 1975 to 1976. From 1 January commercials were introduced on the television. The same year, television was separated from All India Radio and as an independent media was called Doordarshan.

Doordarshan National Programme was started in 1982 and colour television was also introduced in the same year.

## Television as a Medium

Television is an audio-visual medium. It provides visuals along with sounds. Because of this distinctive feature, television dominates over other media of mass communication. In its presentations television carries some of the characteristics of film, stage and radio. If the language of radio consists of sounds and spoken words, then the language of television contains various types of visuals, i.e., stills to moving pictures and various types of natural and artificial sounds.

Television does not always require the words to construct a message. Visuals have the capability of doing so. For instance, in radio the description of mountains covered with snow requires a language, speech and style that create an image of snow-covered mountains in the minds of the listeners whereas in television the visual of snow-covered mountains alone is enough to send the message across to the viewer without using a single word.

Television is a medium of moving visuals. Still pictures create dullness and moving visuals fill the screen with life. Television has the capability of presenting the visuals in the way these exist, whereas the description of any visual through spoken words and sounds may create various images with various interpretations in the mind of the listeners.

Television is a medium people can rely on. Watching the event with one's own eyes leaves no scope for doubt. We rely on print but want to listen to the information on radio to make ourselves one hundred percent sure. In spite of listening to the information on radio we want to watch it for the sake of authenticity and reliability. People did not believe in the grave intensity of the massacre brought by Pol Pot till they watched the heaps of skeletons on television. Watching people, events, happenings, etc., does satisfy us because we know that camera does not lie. But many times camera projects not so true picture as well. A close shot of a flooded street can turn it into a wide flooded area and a long shot of drought can give an impression of just a dry barren area.

Television not only strengthens one's belief about the events being telecast on it, but also attracts masses much more than print or radio. One can sit and continue watching for hours together without getting bored. This silver magic of the television screen is producing hundreds of couch potatoes all over the world. Reading a book or a newspaper demands time and compels one to think in order to understand the text. Radio provides ample time to do any other activity while listening, yet it requires lots of attention to visualize the message for better understanding. Television makes the person just watch without giving him time to think and rationalize. It takes away one's valuable time without letting him know about it.

## Use of Television

Television has a distinct characteristic of capturing the audiences which was considered as the best tool for teaching and training the mass audiences. Its audio-

## NOTES

## NOTES

visual technology makes it more effective than radio that depends solely on the audio channel. By the way of entertaining and informing the masses, it can motivate them in many ways. From the very beginning, the experts were of the view that television can make difficult and tough aspects of various subjects interesting and easy to understand through its distinct quality of demonstrating them visually with a better presentation.

The State university of IOWA used television as an instructional medium in 1932 on an experimental basis. Since then there is no looking back and many universities, private organizations and various governmental departments have started using television as an instructional medium not only in the field of education but also in the arena of health, environment, etc., all over the world.

In India, since its inception, television was considered as an appropriate and efficient tool which could be used in education and development. Educators planned out a project for imparting education to schools. This first developmental project of Indian television was designed for the secondary schools of Delhi. The broadcasts were syllabus based and their aim was to improve the standards of teaching science. Very few schools had laboratories, equipments and well-qualified science teachers. This new teaching method was welcomed by the students and teachers. This project was made possible with the financial aid by the Ford foundation. In 1969, UNESCO found in a survey that schools having television sets had performed better than the other schools. In those days not every house or school had television set.

A specially designed project called 'Krishi Darshan' for farmers was started on 26 January 1966. The aim was to inform the farmers about the latest developments in agriculture and new techniques of farming.

### 9.6.1 Cinema

Apart from using language for communication, human beings have been using visual messages for communicating. The reason for this is our dependence on our eyes for receiving maximum amount of information as eyes are the most important sense organ.

The growth of cinema could be traced back to the cave paintings. The painting as a medium of reproducing the reality in terms of landscape and portrait has led to the invention of camera that further fuelled our imagination to think about inventing moving images.

The word cinema is derived from Greek word *kineto* which means 'movement'. Thus the word 'movie' came into existence. The technique of films is related to the discovery and development of photography. It was in the early 19th century when scientists were working on optics. They invented many devices like thaumatrope of Dr. Filton in 1826, Phenakistoscope of the Belgium scientist Joseph Plateau, stroboscope of Viennese scientist Simon Stampfer to name a few. The working principle of all such devices was same, i.e., a disc with painted pictures of



different movements of an object on it, when rotated gave an impression as if the object is moving. Later on this principle E.J. Marey of Paris devised a photographic gun in 1882 for taking the pictures of moving objects like birds and animals. Seven years later he modified his camera where in place of a roll of light sensitive paper, he used celluloid film. He named his camera as 'chronophotographe'. An Englishman Edward Muybridge used a battery of cameras in a row to record the movements of racing horses somewhere in 1877. Thomas Alva Edison experimented with moving pictures under the direction of W.K.L. Dixon in 1888. Thomas Alva Edison invented a device called kinetoscope in 1895. In 1896, Lumiere Brothers invented an improved version and named it as Cinematographe in 1896. Dixon made a remarkable effort by using celluloid films designed by George Eastman. These celluloid films later became the best medium for photography as it was possible to roll them. The camera that Edison had designed was heavy thus not portable.

French brothers Louis Lumiere and Auguste Lumiere succeeded in inventing a portable, suitcase sized cinematographe or camera that contained a film processing unit and a projector. The technology of Lumiere's cine-camera was based on his contemporary Edison's bulky camera. Their first film depicted the arrival of a train. The first public show of films by Lumiere brothers was organized in France in 1895.

### Genres of Films

Documentary, feature film and telefilms are amongst some forms of films. It is a form of moving pictures meant to document facts and aspects of reality. According to a Scottish documentary maker, a documentary is a 'creative treatment of actuality'. In 1926 he defined a non-fiction film as a documentary.

An American film maker Pare Lozentz defines a documentary as 'a factual film', which has to be dramatic in nature. A documentary can be classified into several genres. A very popular form of documentary in the early 20th century was called 'travelogue films'. It was also known as 'scenics'. Frank Hurley, an Australian photographer and adventurer, made a documentary named as 'south' in 1919 on Trans-Antarctic expedition. He had participated in several Antarctic expeditions. He also served as an official photographer with Australian forces during World War II. This documentary had depicted the failure of the expedition. 'Nanook of the North' produced by Robert J. Flaherty in 1922 is said to be a romanticized documentary.

Documentary can also serve as propaganda film. Frank Capra's 'Why we fight' in 1944 was commissioned by the Government to convince the United State's public that it was time to go to war. During 1940s, British documentary makers blended propaganda, information and education in their propaganda documentaries. Their approach was more poetic in nature.

Before each election politicians convey their achievements to public through propaganda documentaries. Making a documentary on wildlife is an interesting

### NOTES

## NOTES

task that requires lots of patience where as a documentary on a biography demands well-researched facts.

With time and growth of technology the trends in documentaries are changing. Instead of portable camera and sound equipment, handycams are used for making documentaries which reduces the cost of production. Usually documentaries are of short duration, say from 5 minutes to 30 minutes. They are cost effective and require less efforts and time.

### Feature Film

A feature film is a film of full length. American Film Institute and the British Film Institute define feature film as a film with duration of 40 minutes or longer. In India the duration of a feature film is usually more than 120 minutes. *The Chamber's Dictionary* defines feature film as a long cinematograph film forming the basis of a programme. Feature films are also called movies.

Story types or genres develop the category of films. Action films include stunts, chases, battles and fights and usually demand high budget. Adventure films are exiting stories of hunts, searches for the unknown and unseen. They are full of new experiences. Comedies are meant for provoking laughter and amusement. The light-hearted plots of comedies attract wide audiences. Other genres include horror films, crime and detective films. Dramas are serious presentations whereas musicals are song and dance based films. Historical films are big budget films portraying mythical, legendary characters. Science fictions are visionary and imaginative and war movies are sensitive. Sometimes, a new genre develops on public demand or on the demand of current political and social atmosphere like films on terrorism, diseases, marriages, family relations, etc. Apart from the commercial films there are certain films which are not dramatized, but filmed according to the real life situations. These types of films are called parallel films (new wave films in France and India).

A film is created by recording photographic images using cameras. Originally the term 'film' was used for a photographic film. A film can be called as an extension of photography. A cinemascope film, in comparison to a regular film, has a wide length and a short height. Films can be educative, for instance a film based on the works of a leader or on a classic novel. They can be made for propaganda or can be artistic in nature.

### Telefilm

Telefilms are the films produced for television broadcasting. Usually they are short films with a low budget. Doordarshan has produced certain quality telefilms in the past. It has introduced the works of famous writers like Premchand's *Nirmala*, Bhishma Sahani's *Tamas*, etc., in the form of telefilm. Such films are either funded by the ministry, NFDC or commissioned by Doordarshan. The regional centres of Doordarshan have also produced many telefilms of one hour duration. The FTII produces telefilms that are telecast on Doordarshan.

Famous directors like Shyam Benegal and M.S. Sathyu have also directed several class telefilms. Telefilms on Doordarshan have also served as laboratories for the young upcoming directors and actors as they had experimented with the subject, form, content and innovativity.

### **Cinema as Medium**

Most of the cinema is meant for entertainment. It is a product that is made for consumption. Such films may be enjoyed by those who simply want to relax and wander in a world of fantasies. This dreamy effect makes the audience forget about the real world; rather the reel world becomes real to him. It is a very powerful impact that depending on the theme and treatment of the film can do wonders on the one hand and on the other can bring disaster to the lives of the viewers.

Sometimes the impact of the films is not realised at once. It lives with us in our subconscious and appears gradually. In fact the impacts hide in our thoughts and take their own time for their realisation.

Cinema has changed with time and has always tried to cope with the changing reality. It picks up the issues from the society. Serious and grave issues drive us to think about the needs of the society. They can make us more responsible towards our society by creating sensitivity and feelings for our own people. On the other hand violence, crime, vulgarity, lust and unreal lavish lifestyles corrupt the minds suggesting ways to achieve all that is shown at any cost. Thus it can also produce lame and uncultured class of people.

Most of the commercial cinema has a drastic effect on youth. They blindly follow their ideals in fashion, glamour and glitz. They strive to behave like them and try to look like them. This hampers their mental and psychological growth that is required in the building of a nation.

One of the good things that cinema has brought to us is an understanding of creativity through cinematography. Indian films too have given the best lyrics, composers and singers to the society. Cinema has introduced various forms of music, from classical to folk and from devotional to pop. Films made on the literary works have not only introduced to us great writers and their thoughts but also helped in developing a better understanding of the society and its people.

---

## **9.7 NEW MEDIA**

---

The last two decades of the 20th century were a remarkable period from the point of view of media and communication technology. It was also a period of the emergence of globalization and expansion of markets.

The advancement in the field of information technologies not only realised the dream of Marshal McLuhan of the global village by inventing the technology of the Internet, it also changed the technologies of print, radio and television.

### **NOTES**

## NOTES

The unceasing innovations in the telecommunication technologies not only helped the growth and expansion of the Internet, it also paved the way for a new media nowadays popularly called mobiles. Mobile technology in convergence with information technology has enormous potential in the days ahead.

### **History of Computers and Internet**

The innovation of the first computer called Mark-I is as recent as 1940, though the origin of computers is traced back to 3000 years back when the first computing machine known as *Abacus* was developed in China. Later, Charles Babbage was credited with the hypothesis which allowed the invention of computer.

The development of computers in the initial 15 years was very slow as the vacuum tubes were used in them. The ENIAC (Electronic Numerical Integrator and Computer) machine developed in 1942 was very huge as it used around 18000 tubes. It was only after the emergence of silicon transistor in 1954 and the invention of integrated circuits around 1964 that the research and development of computers gained pace. These two major inventions allowed the manufacturing of small size computers. In 1948, the invention of transistors by Bell Laboratories by Shockley, Brattain and Bardeen led to the improvements in computer technology which ultimately led to the making of Integrated Chips (IC).

Computers were not very popular in the initial days as one had to learn a number of commands to operate them. They were mainly used by the scientists and researchers in general and the computer scientists in particular. It was only in 1984 when the Apple machine innovated by Steve Jobs and Steve Wozniak was launched in the market that the fancy for this wonderful machine caught at the public level. Apple was the first GUI (Graphic User Interface) machine which even a child was able to use for making drawings or play games.

The computer during these days became much more than just a number-crunching machine. It was mainly used as sophisticated word processor in comparison to the recently developed electronic typewriter. Some people also used these machines to make drawings or draw charts and graphs. A few years later they became effective publishing machines when the software like Ventura or Page maker along with many other software for creating drawings or digitalizing photographs were launched in the market.

### **Multimedia Technology, World Wide Web and Broadband**

The next phase in the development of computers and the related technology which was by now called information technology was the development of multimedia computers. These machines had the capability of digitalizing visuals like photographs and audio including speech and music. Software was also developed to create

animations. The technology of the Internet was also developed very rapidly during the same period. All these developments necessitated researches on computer architecture to increase the speed of processing and on telecommunication technologies for increasing the speed of data transfer across telephone lines.

The multimedia messages required more space to store them. Hence, we saw a rapid growth in storage media where one moved away from 5.25 inch floppies to 650 MB CD ROM and later to DVDs on one hand and from 10 MB hard disc to higher capacity hard disc ranging from 10 GB to 1 Terrabyte and more. The computer architecture changed in leaps and bounds as we saw the primary 8086 processors with 8 bit architecture getting replaced by 286, 386, 486, Pentium and P17 with 16 bit to 64 bit architecture. The processor speed was increased from the initial 5 MHz to 3.2 GHz. Similarly, the modems used for transmission of data became redundant as the Internet changed itself from the text only form to multimedia web and the communication lines using copper wire too became redundant as the high speed data transmission required the optical fibre capable of working as a broadband transmission line.

The World Wide Web (www) too has changed the generation to web2 which is increasingly used not only for audio and video uploading and downloading but for social networking as well. It has become a more popular media than radio and television. The WWW also has a literacy component as the portals are being used to read news and other information. The encyclopaedic storage of the Internet has also made it an educational tool.

The only drawback is that it is still far away from the kind of reach that radio and television possess. It has not penetrated to the desired level even in the developed world.

### **Mobile Communications**

The advances in telephony have surprised every one of us. From the manual operator-driven exchanges it has moved to the automatic digital exchanges and made it possible to get connected with people anywhere in the world without losing any time. As if that was not enough, the telecommunication technology moved away from the line-based communication to wireless radio communication and later incorporated satellites in its operations.

The cumbersome telephones have been replaced by the handy mobile of ever-diminishing sizes. The digital technology provided by the developments in the information technology have allowed mobiles to become a convergent media that can today be used to take snaps, listen to radio, view television programmes, write messages and even articles along with its basic function of connecting people with the help of voice communication. In this sense, it is the new media for future with lots of promises.

### **NOTES**

Interestingly, the mobile technology has seen a rapid and huge penetration even in the developing countries. In India alone it has grown considerably faster than the commuters and the Internet.

## NOTES

### Check Your Progress

6. What led to the invention of the radio?
7. When was the first ever satellite TV signal sent?
8. How is a film created?
9. What allowed the rapid research and development of computers?

---

## 9.8 ANSWERS TO CHECK YOUR PROGRESS QUESTIONS

---

1. The role of mass media in mass communication is to disseminate information to all the people in the world at a single point of time.
2. A piece of printed paper that is clipped to community boards, pasted on walls or simply hung on the doors and trees is known as 'poster'.
3. A brochure is a type of pamphlet or leaflet. It can be a single sheet or can have multi-sheets. In the latter case, it is stapled on the creased edge.
4. Television was introduced in the country in 1959 but its usage was very restricted.
5. Satellite Instructional Television Experiment or SITE is considered to be one of the biggest techno-social communication experiments in education and rural development. The one-year experiment (August 1975 – July 1976) aimed to provide direct broadcasting of instructional and educational television in 2400 villages in the states of Andhra Pradesh, Bihar, Karnataka, Madhya Pradesh, Orissa and Rajasthan.
6. The need for rapid long-distance communication led to the invention of the radio.
7. The first ever satellite TV signal was sent from Europe to the Telstar Satellite in 1962.
8. A film is created by recording photographic images using cameras.
9. After the emergence of silicon transistor in 1954 and the invention of integrated circuits around 1964 that the research and development of computers gained pace.

---

## 9.9 SUMMARY

---

- Mass communication is defined as one-to-many type of communication. It requires certain type of media that allows one-to-many communication. Radio, cinema, print, television and the Internet are the technologies of media that make mass communication possible.
- The most recent and the most revolutionary invention in the field of printing technology is that of desktop publishing. It is a new way to create a print document in less time and at less cost. Linked with the Internet technology of data transfer, it has given a new lease of life to the newspapers in this age of faster communication like television and online journalism.
- A piece of printed paper that is clipped to community boards, pasted on walls or simply hung on the doors and trees is known as ‘poster. A poster includes textual as well as graphic information. Some varieties of posters are completely graphical or textual representations.
- Flyers or handbills are single-page unfolded leaflets usually meant for advertising services or products. They can be used by individuals in promoting their business, product, services or any special cause. Flyers can be handed to people in shopping complexes.
- Edwin Armstrong in 1933 developed a new kind of radio signal based on frequency modulation. Frequency modulation is a method of conveying information over a carrier wave by varying its frequency. This is different from AM in which the amplitude of the carrier wave is varied while its frequency remains constant.
- Satellite radio is a digital radio signal. It is the latest in digital radio technology. It is relayed through satellites hence can be received in a much wider geographical area than the terrestrial AM and FM radio. Satellite radio services are subscription based and they are provided by commercial companies.
- The word cinema is derived from Greek word *kineto* which means ‘movement’. Thus the word ‘movie’ came into existence. The technique of films is related to the discovery and development of photography. It was in the early 19th century when scientists were working on optics. They invented many devices like thaumatrope of Dr. Filton in 1826, Phenakistoscope of the Belgium scientist Joseph Plateau, stroboscope of Viennese scientist Simon Stampfer to name a few.

## NOTES

---

## 9.10 KEY WORDS

---

- **Broadcasting:** It means the transmission of television and radio signals over air from fixed terrestrial transmitters and with limited range.

## NOTES

- **Hertz (Hz):** It is the unit of measurement of cycles per second used for the sound portions of the electromagnetic spectrum.
- **Communication:** It is a process of increased commonality or sharing between participants on the basis of sending and receiving messages.
- **Newspaper:** It refers to the print media form appearing regularly (usually not less than once a week), containing (at least) reliable reports of recent or ongoing events of general interest and offered for public sale.
- **Cable Television:** It means a television broadcasting system in which signals are transmitted by cable to subscriber sets.
- **Modulation:** It refers to the pattern of waves in the electromagnetic spectrum.
- **Short Wave:** It refers to a directional system of broadcasting in which the signal is bounced from the ionosphere to a location on the earth
- **Bandwidth:** It means the width (i.e., range of frequencies) of a channel or signal carried between a transmitter and a receiver.
- **Broadsheet:** It refers to newspapers having the size  $600 \times 380$  mm ( $23\frac{1}{2} \times 15$  inches), generally associated with more intellectual newspapers
- **Tabloid:** It refers to the publication having half the size of broadsheets at  $380 \times 300$  mm ( $15 \times 11\frac{3}{4}$  inches) and often perceived as sensationalist in contrast to broadsheets.
- **Multimedia:** It means the combination of various forms of media (texts, graphics, animation, audio, etc.) to communicate information
- **Supplements:** It means an additional section of a newspaper devoted to a specific subject.
- **Digitalization:** It refers to the computerization of all data transmission, storage and processing employing the binary code, and as such the basis for convergence of media.
- **Amplitude Modulation (AM):** It means the encoding of a carrier wave by variation of its amplitude in accordance with an input signal.
- **Frequency Modulation (FM):** It means the encoding of a carrier wave by variation of its frequency in accordance with an input signal.
- **Parallel Cinema:** It refers to the alternative to the mainstream commercial cinema, a specific movement in Indian cinema, known for its serious content, realism and naturalism, with a keen eye on the sociopolitical climate of the times.



---

## 9.11 SELF ASSESSMENT QUESTIONS AND EXERCISES

---

### Short-Answer Questions

1. Write a short-note on media for mass communication.
2. What are periodicals?
3. What are the different tools of new media?
4. What do you understand by Satellite Radio?
5. Briefly discuss the history of computers.

### Long-Answer Questions

1. What are the basic characteristics of the modern media of mass communication?
2. What are the important milestones in the evolution of the printing technology? Describe the different genres of the print medium.
3. Analyse the significance of radio as a means of mass media. Discuss different types of radio networks on the basis of the technology used.
4. Describe the basic features of the different types of films.
5. Describe the advantages enjoyed by the television as a medium of mass communication in relation to other forms of communication.

---

## 9.12 FURTHER READINGS

---

- Mcquail, Denis. 2013. *Journalism and Society*. New Delhi: Sage Publications.
- Bro, Peter. 2018. *Models of Journalism: The Functions and Influencing Factors*. London: Routledge.
- Burns, Lynette Sheridan. 2002. *Understanding Journalism*. New Delhi: Sage Publications.
- Raghavan, G.N.S. 1994. *Press in India: A New History*. New Delhi: Gyan Publishing House.
- Sharma, K. Suresh. 2006. *Press in India*. New Delhi: Vista International Publishing House.
- Parthasarathy, Rangaswami. 1984. *Basic Journalism*. New Delhi: Macmillan India Limited.

### NOTES

NOTES

---

## UNIT 10 PUBLIC BROADCASTING AND THE CABLE REVOLUTION

---

### Structure

- 10.0 Introduction
- 10.1 Objectives
- 10.2 Prasar Bharati Bill
- 10.3 FM and Community Radio
- 10.4 DTH and Cable Revolution
  - 10.4.1 Current Status
- 10.5 Answers to Check Your Progress Questions
- 10.6 Summary
- 10.7 Key Words
- 10.8 Self Assessment Questions and Exercises
- 10.9 Further Readings

---

### 10.0 INTRODUCTION

---

In the previous unit, you learnt about the different types of media and their functions. This unit discusses public broadcasting. Public broadcasting includes radio, television and other electronic media outlets whose primary mission is public service. In most places around the world funding of the public sector comes from the government, especially via annual fees charged on receivers. In India, Prasar Bharati is the public broadcaster. It is an autonomous corporation of the Ministry of Information and Broadcasting and consists of the Doordarshan television network and All India Radio. The unit will also discuss DTH and the Cable Revolution, as well as FM and the Community radio.

---

### 10.1 OBJECTIVES

---

After going through this unit, you will be able to:

- Describe the Prasar Bharati Act
- Discuss AIR as well as community radio
- Explain the cable revolution in India

---

### 10.2 PRASAR BHARATI BILL

---

Prasar Bharati was established following a demand that government owned broadcasters in India should be given autonomy like those in many other countries.

The Parliament of India passed an Act to grant this autonomy in 1990, but it was not enacted until 15 September 1997. The Prasar Bharati Act provides for establishment of a broadcasting corporation, to be known as Prasar Bharati, to define its composition, functions and powers. The Act grants autonomy to All India Radio and Doordarshan, which were previously under the government control. The Act received the assent of the President of India on 12 September 1990. After being unanimously passed by the Parliament, it was finally implemented in September 1997. By the Prasar Bharati Act, all the property, assets, debts, liabilities, payments of money due, all suits and legal proceedings involving Akashvani (All India Radio) and Doordarshan were transferred to Prasar Bharati.

Prasar Bharati Act stipulates that the general superintendence, direction and management of affairs of the Corporation vests in the Prasar Bharati Board, which may exercise all such powers and do all such acts and things as may be exercised or done by the Corporation.

Prasar Bharati Board consists of the following:

- Chairman
- One Executive Member
- One Member (Finance)
- One Member (Personnel)
- Six Part-time Members
- Director-General (Akashvani), ex-officio
- Director-General (Doordarshan), ex-officio
- One representative of the Union Ministry of Information and Broadcasting (India), to be nominated by that Ministry
- Two representatives of the employees of the Corporation, of whom one shall be elected by the engineering staff from amongst themselves, and one shall be elected by the other employee from amongst themselves

The President of India appoints chairman and the other members, except the ex-officio members, nominated member and the elected members. The Board shall hold not less than six meetings every year, but three months shall not intervene between one meeting and the next meeting.

### **Functions and Objectives**

- (a) The primary duty of the Board is to organize and conduct public broadcasting services to inform, educate and entertain the public and to ensure a balanced development of broadcasting on radio and television.
- (b) The Board shall, in the discharge of its functions, be guided by the following objectives, namely:
  - Upholding the unity and integrity of the country and the values enshrined in the Constitution

### **NOTES**

## NOTES

- Safeguarding the citizen's right to be informed freely, truthfully and objectively on all matters of public interest, national or international, and presenting a fair and balanced flow of information including contrasting views without advocating any opinion or ideology of its own
- Paying special attention to the fields of education and the spread of literacy, agriculture, rural development, environment, health and family welfare and science and technology
- Providing adequate coverage to the diverse cultures and languages of the various regions of the country by broadcasting appropriate programmes
- Providing adequate coverage to sports and games so as to encourage healthy competition and the spirit of sportsmanship
- Providing appropriate programmes keeping in view the special needs of the youth
- Informing and stimulating the national consciousness in regard to the status and problems of women and paying special attention to the upliftment of women
- Promoting social justice and combating exploitation, inequality and such evils as untouchability and advancing the welfare of the weaker sections of the society
- Safeguarding the rights of the working classes and advancing their welfare
- Serving the rural and weaker sections of the people and those residing in border regions, backward or remote areas
- Providing suitable programmes keeping in view the special needs of the minorities and tribal communities
- Taking special steps to protect the interests of children, the blind, the aged, the handicapped and other vulnerable sections of the people
- Promoting national integration by broadcasting in a manner that facilitates communication in the languages in India; and facilitating the distribution of regional broadcasting services in every state in the languages of that state
- Providing comprehensive broadcast coverage through the choice of appropriate technology and the best utilization of the broadcast frequencies available and ensuring high quality reception
- Promoting research and development activities in order to ensure that radio broadcast and television broadcast technology are constantly updated

### **Check Your Progress**

1. Why was Prasar Bharati established?
2. What is the primary duty of the Prasar Bharati board?

### **NOTES**

---

## **10.3 FM AND COMMUNITY RADIO**

---

The All India Radio (AIR) came up as an instrument of establishing and maintaining the British hegemony, but after Independence the radio committed itself to the development programmes of the Government of India and became the most effective media of nation building. It took up the task of helping in the development of the economic scenario of the country. The Indian Constitution was adopted in 1950 and authorized a strong role for the Indian State in the economic development of the country. The use of broadcasting was further considered to be a development process that was naturally a consequence to this state-led developmental philosophy. Indian radio was specially designed to contribute to the process of social modernization, which was an important prerequisite of economic development. The dominant development philosophy of the time scrutinized the problems of development as the basic ones in the developing countries. These internal causes included traditional value systems; lack of entrepreneurial ability, lack of innovation and lack of a national consciousness and experts could suggest only communication solutions to bring upon. The main problem was that the old ideas were influencing the young minds thus hindering the process of social change and modernization. The role of broadcasting provided an inlet for the flow of modern ideas.

### **All India Radio**

Keeping in mind the impact and strength of radio, the Government of India launched several projects in the field of education, health care, agriculture, etc. They were School broadcast (1937), Adult education and community development (1956), farm and home broadcast (1966), university broadcast (1965), etc.

Today, the radio has become interactive and has started live broadcast too where people can participate by sharing their views on topics that are discussed. Almost all services of AIR offer live participation of audiences. FM radio stations are much ahead in this regard. People can inform FM stations about various happenings and events they witness while the programme is on air like road accidents, traffic jams, sudden fall in temperature or rains in a particular area, storms, etc. Thus, people could associate themselves more with radio. They found themselves participating in the programme which was certainly exciting. This technique also increases the listenership which is good for radio channels for their survival by getting more sponsors.

## NOTES

Some governments have provided aid or sponsored programmes on education, agriculture, health, women empowerment, etc. But this is not sufficient. More guidelines and more schemes and formats have to be checked out, to bring remote population close to each other to work for issues like hunger, poverty, unemployment, and so on. Masses should just not enjoy being on air and talking rubbish and irrelevant things; they must come forward with new innovations and constructive ideas to fight against these problems.

For the purpose of educating adults and developing the community, a project named 'Radio Forums Project' was started in 1956. This was an agriculture-based project that was commenced with the help of UNESCO in Maharashtra. 144 villages in the vicinity of Pune were benefitted from this project. Another successful project was started in 1966 for farmers. During the Green Revolution farmers adopted useful agriculture-related techniques that were broadcast on radio. This programme was aired under agriculture extension project of the Government of India. The broadcasts were planned to provide information on agriculture technology, fertilizer insecticides, seeds, agriculture machines, etc. Those days with the efforts of radio broadcast and farmers' inclination and interest in innovative practices, a new variety of rice was harvested in abundance. It was popularly named as 'Radio rice'. Even today, various stations of the All India Radio are regularly broadcasting programmes for farmers and their community with an aim to education, inform and to entertain them at the same time. Radio is providing significant information through popular programmes on various issues like environment protection, land and water conservation, role of panchayats, biotechnology for agriculture, among others.

Radio empowers rural and urban women with its specially-designed programmes targeted to educate them in the areas like health, family welfare, child care, food and nutrition and home management. It also educates them about their rights. Radio programmes on family welfare in various formats like discussions, drama, jingles and feature have made women aware of the benefits of a small family.

In 2003, AIR broadcast an innovative community-based radio programme titled 'Panchayat Vani'. This programme is aimed to spread awareness about the functioning of Panchayati Raj institutions in three districts of Bihar, namely Muzaffarpur, Madhubani and Khagaria. The programme was produced by CENCORD in collaboration with the Delhi-based Participatory Research in Asia. Panchayat Vani was initiated in early 2003 to inform local community about the need to strengthen the panchayati raj institutions. This programme has been replicated in many other parts too. The famous development journalist, editor and the member of the committee for the autonomy of All India Radio B.G. Varghese says 'Radio has a community building capacity if you can create interest in the context of what is being broadcast. People identify with the programme and the situation. They feel that they are sharing (their problems) with others.'

Andaman and Nicobar Islands situated in the Bay of Bengal, is 1200 km. away from the main territory of India. Till the mid-20th century, radio was a major source of information and communication. But, in the 21st century, which is known as the era of information technology, television, cable channels, videoconferencing and the Internet have made the communication quicker and cheaper and made the radio outdated. But, in Andaman and Nicobar Islands the radio has still a place of pride. Rural people depend upon the radio for national, international and regional news, weather condition, arrival and departure of ships, boats, etc. Farmers in these islands listen to radio regularly particularly more the programmes related to agriculture, animal husbandry and veterinary, fisheries, and fishing. Forty years back in 1963 an All India Radio station was established in these Islands. Since then it is providing its services continuously to the islanders. It broadcasts regularly two agricultural programmes daily in Hindi, 'Kishano Ke Liye' in the morning at 5.55 a.m. and another 'Krishi Jagat' at 6.15 p.m. Both the programmes are very popular among the farmers.

Radio has also some inherent limitations which need to be understood and addressed in order to provide effective programmes. Radio as such, is one-way, evanescent and its audience is passive. Moreover, even well-absorbed and well-rehearsed knowledge seldom in itself leads to long-term changes in practice. The transition from awareness to trials and eventual adoption of new practices depends on the existence and effectiveness of networks of extension service that are adequately linked to the broadcasts. Unfortunately, in many poor countries these extension services are rarely sufficient.

A further important aspect is the timing of the broadcast. Radio needs to be programmed and messages designed and disseminated at the appropriate time. Also the relevance of the topic for the current season on the agricultural calendar has to be taken into account and farm radios need to be ahead or within the farming activities calendar.

Agriculture project designers should consider rural radios in their projects and plan communicating to the stakeholders through this means from the beginning. Public emissions that are followed by the entire village on the public square could be followed by a local facilitator who is able to verify the perception of the rural actors on a number of issues providing feedback to the program planers and implementers.

In order to be successful, radio broadcasts needs to create a strong link between the farmers, radio broadcasters and the extension workers. Moreover, programmes should feature a certain entertainment value and should be scripted in a way that compels people to become customary listeners.

### **Community Radio**

Community radio has a lot of advantages to be the perfect mass communication tool for development communication. It is playing and can further play the significant

## **NOTES**

## NOTES

role to develop the backward areas and bring them at the main stream of developmental process.

During the recent years, many community radio stations have been established by different NGOs. These stations are working excellently. They have been focusing on social, agricultural and livelihood related problems. They are also raising the voice against the corruption at village, block and district level. Jharkhand based Radio Manthan has played a very important and daring role in this regard. Radio Manthan has shown the democratic, peaceful and effective way to fight against corruption. Educating people about their rights is also a vital issue taken in hand by many community radios.

Community radio is very effective in areas with tough geographical features especially in the hill areas. It can be used to circulate useful information with a great ease. A number of community radio stations are working in Uttarakhand, a hilly state for example- Radio Pradeep, Mandakini ki Awaz. Hevalwani, Sristi, etc. They are working for the development of remote and backward hilly area.

The agriculture department of the Government of Bihar has the permission to establish a community radio station in Samastipur district dedicated to agriculture and related activities. This radio will educate the farmers about new techniques of agriculture, marketing options and other useful things. Depending on the success and popularity of this project, the department of agriculture plans to establish more such radio stations.

---

## 10.4 DTH AND CABLE REVOLUTION

---

Television in India began when the Delhi Television Centre came into existence on September 15, 1959. In the beginning this centre used to beam 20 minutes programme twice a week. To make the experiment successful, 180 ‘teleclubs’ were formed where TV sets provided by UNESCO were put up. In 1961, a survey conducted by UNESCO concluded that ‘some impact’ was made by teleclubs’ programme. In addition to social education programme – the very basis of setting up the TV centre in the capital, the centre introduced information and entertainment programme from August 1965. A TV production studio was also set up with the help of the Federal Republic of Germany.

With the addition of news, information and entertainment programme, the service was extended to three hours by 1970; aside from this, two weekly programme of 20 minutes duration each for ‘teleclubs’ were already running. Another programme called ‘Krishi Darshan’ for farmers in 80 villages was also added. Meanwhile, the range of transmitter was extended to 60 k.m. and the farmers of Haryana and Uttar Pradesh could easily pick it up.

India during that year imported 22,000 TV sets but by mid-seventies the number of television sets being manufactured in India soon crossed the 100,000 mark. In view of Indira Gandhi government’s popularity and demands from the



advertising industry, television manufacturers and consumers in Indian cities, it was decided to expand the medium nationwide. The number of TV sets in Delhi and neighbouring states amounted to 200,000 sets. Such was the encouragement that the Bombay Centre was opened in 1972 and a year later, TV centres became functional in Srinagar, Amritsar and Pune though only as relay centres. A couple of years later Kolkata (then Calcutta), Chennai (then Madras) and Lucknow centres became operational. January 1, 1976, marked the beginning of 'commercials' being telecast at all these centres.

Another milestone was achieved the same year when television was separated from All India Radio. The ministry of I & B recognised television as an independent media unit and named it 'Doordarshan'. This decision taken by the ministry raised hope for improvement in the quality of the content and duration of the programme. The very next year saw terrestrial transmitters being set up in Jaipur, Hyderabad, Raipur, Gulbarga, Sambhalpur and Muzaffarpur. This extended television coverage to a population of more than 10 crores. It was during this year that political parties shared equal radio and TV time with the ruling party for their election campaigns – a unique and unparalleled decision in the history of Indian broadcasting.

### **Satellite Instructional Television Experiment (SITE)**

Launched as an experimental satellite communications project in 1975, the Satellite Instructional Television Experiment (SITE) was aimed at providing informational television programme to rural India. NASA and the Indian Space Research Organization (ISRO) jointly designed the project. The experiment had a two pronged strategy - first to educate the poor on various issues via satellite broadcasting, and secondly to help India gain technical experience in the field of satellite communications. The experiment covered 2400 villages in six states of Orissa, Bihar, Rajasthan, Madhya Pradesh, Andhra Pradesh and Karnataka. The experiment ran for one year from 1 August 1975 to 31 July 1976. While All India Radio produced the television programme, NASA stationed the ATS-6 satellite above India for the duration of the project broadcast. Various international agencies such as the UNDP, UNESCO, UNICEF, ITU and Aerospace were major players in supporting the project while General Electric, Hughes Aircraft, The Massachusetts Institute of Technology, and so on, were the minor players. The experiment was successful because it played a major role in helping India develop its own satellite programme known as INSAT. It also made clear that India could use advanced technology to fulfil the socio-economic needs of the country. SITE was followed by similar experiments in various countries, which showed the important role that satellite TV could play in providing education.

The INSAT series of domestic communication satellites and microwave cable networks provided India the infrastructure for a national satellite hook-up. With India's hosting the Asian Games in 1982, the rapid expansion of television networks got a further boost. During the middle of 1980s, New Delhi and Mumbai

## **NOTES**

## NOTES

(then Bombay) witnessed the introduction of a second channel which rapidly went to other metros as well. It was called DD-1.

After the Asian Games were over, the television industry in India saw the entry of film directors and producers. Progressive directors like Govind Nihalani, Saeed Mirza, Shyam Benegal and Basu Chatterjee, who specialised in directing low budget films, found a good expression for themselves in television. Nihalani came out with *Tamas*, a serial on India's partition, Saeed Mirza produced a socio-political show called *Nukkad*, while Basu Chatterjee's *Rajani* made a mark on the small screen. Benegal, however, failed to attract viewers to his Sunday morning production known as *Bharat ek khoj* which was inspired by Jawaharlal Nehru's book *Discovery of India*.

In the late 1980s, what took Indian television by storm was the entry of bigwigs of commercial cinema into the television industry. Noted filmmaker Ramanand Sagar made *Ramayana* while another colleague B.R. Chopra produced *Mahabharata*. Both of them were Sunday morning serials, and when they were telecast, it was said that there used to be a curfew like atmosphere in most of India. After their success, soon political satires like *Kakkaji Kahin* and episodes of *Malgudi Days* followed suit.

### Rapid Strides in Telecast Technology

Telecast technology has undergone a sea change through all these decades. Initially, the technology employed was terrestrial television where the range of the transmitter used to be limited, say only about 50 kilometers. Thus, the signals reached Delhi and some of its neighbouring states like Uttar Pradesh, Haryana and Rajasthan only. Delhi and its local studio used to telecast programme to Mumbai and other places and viewers of these cities had no option but to remain content with whatever they got. What was a revolutionary change was the arrival of cable TV in the early 1990s.

Satellite based TV transmission in India took almost one and a half decades to come into existence. Although it turned out to be successful during its trial period as part of SITE, it took off only in the early nineties when STAR (Satellite Television Asia Region) TV arrived from Hong Kong. With this development, national and international channels and programme in different Indian languages became accessible to Indian viewers throughout the country. But STAR alone was not the solution to the problems of Indian television. For almost 50 per cent of TV households in the country, satellite transmission was simply unaffordable. Therefore, it was imperative that satellite transmission became connected to terrestrial cable. When this occurred, the monopoly that Doordarshan used to exercise automatically ended. As did the monopoly of Hindi and English TV programme. Southern channels like Asianet, Eenadu TV (ETV) and Sun TV and others paved the way for the growth of television in South India and began to get higher ratings and advertising revenues as compared to English and Hindi channels.

In 2003, Doordarshan launched the Direct-to-Home (DTH) deliver mode. In this mode, it became mandatory to have a set-top box (STB) to receive signals direct from communication satellites. This move set the viewer's free from the clutches of cable operators, although it was an additional investment and many thought it was expensive as well. It also inspired channels like Zee TV and Star TV to have their own DTH service – Dish TV and Tata Sky respectively. Today, a majority of viewers in the major cities subscribe to either of the two services.

## **NOTES**

### **10.4.1 Current Status**

DTH service a comparatively recent entrant as compared to cable transmission, has certain technical advantages over cable operations. DTH is an addressable system and covers the entire country. In DTH service a large number of television channels are digitally compressed, encrypted and beamed from very high power satellites. The programmes transmitted through DTH can be directly received at homes by installing small dish antennas at convenient locations in the buildings. DTH transmission service does not require any commercial intermediary, since an individual user is directly served by the DTH operator. DTH Service refers to distribution of multi-channel programmes in Ku Band by using a satellite system, for providing TV signals direct to subscribers' premises. DTH provides subscribers the advantage of geographical mobility meaning thereby that once a customer purchases DTH hardware, he/she can continue to use the same unit anywhere in India.

The Government on 15th March, 2001 issued detailed guidelines and Licensing Agreement for operating DTH services in India which were amended on 6th November, 2007. The eligibility conditions in the guidelines, inter-alia, provide a ceiling of foreign equity holding, including FDI/NRI/OCB/FII, in the applicant company of 49%, and within the foreign equity, the FDI component of 20%. The Department of Industrial Policy and Promotion has liberalized the FDI Policy in electronic media vide Press Note No. 5 (2016 Series) dated 24th June, 2016 with a ceiling for Broadcasting sector of 100% (Automatic route). The Applicant Company must have Indian management control with the majority representatives on the Board as well as Chief Executive of the Company being Resident Indians.

### **Cable TV**

Cable TV forms the backbone of the broadcasting distribution industry and has played a prominent role in the growth of the electronic media sector in the last 20 years. Despite the fast growth of the DTH services, Cable services continue to dominate the distribution of TV channels as of today. The Cable TV service value chain comprises four main supply side entities i.e. broadcaster, Multi System Operator (MSO), Local Cable Operator (LCO) and the end consumer. Broadcaster generates the content to be televised which is received by the viewer by "up-linking" the content signals to the satellite. MSOs downlink the broadcasters'

## NOTES

signals from the Satellite, decrypt any encrypted channel and provide a bundled feed consisting of multiple channels to the LCO.

As per TRAI, there are around 6,000 18 the end consumer. Broadcaster generates the content to be televised which is received by the viewer by “up-linking” the content signals to the satellite. The MSO business is dependent on the broadcaster for content and on the LCO for last mile connectivity and subscription revenue collection. MSO is required to have head-ends for receiving TV signals. LCOs receive bundled signals from the MSO and retransmit this to subscribers in their area through cables. It is estimated that there are around 60,000 cable operators in the country.

There are several drawbacks of analogue cable television system including limited carrying capacity, no provision for selection of a-la-carte channels, lack of transparency of subscriber’s base, distorted quality of picture. The Telecom Regulatory Authority of India (TRAI), in its recommendations dated the 5th August, 2010 on “Implementation of Digital Addressable Cable Systems in India” had, inter alia, recommended that digitalization with addressability be implemented on priority in cable TV services and, accordingly, recommended a time frame comprising four phases for switch over from analogue system to the digital addressable system (DAS) in the cable TV sector detailed later. Addressability means that the signals of cable operators will be encrypted and so received through a Set Top Box after due authorization from the service provider, enabling identification and maintenance of data base for each subscriber, to bring transparency and prevent piracy. Implementation of DAS would benefit all stakeholders.

### Check Your Progress

3. List some of the community radio stations working in Uttarakhand.
4. What was the aim of SITE?
5. When were guidelines related to DT services in India issued?
6. What forms the backbone of the broadcasting distribution industry in India?

---

## 10.5 ANSWERS TO CHECK YOUR PROGRESS QUESTIONS

---

1. Prasar Bharati was established following a demand that government owned broadcasters in India should be given autonomy like those in many other countries.
2. The primary duty of the Board is to organize and conduct public broadcasting services to inform, educate and entertain the public and to ensure a balanced development of broadcasting on radio and television.

3. A number of community radio stations are working in Uttarakhand, a hilly state for example, Radio Pradeep, Mandakini ki Awaz, Hevalwani, Sristi, etc. They are working for the development of remote and backward hilly areas.
4. Launched as an experimental satellite communications project in 1975, the Satellite Instructional Television Experiment (SITE) was aimed at providing informational television programme to rural India.
5. The Government on 15th March, 2001 issued detailed guidelines and Licensing Agreement for operating DTH services in India which were amended on 6th November, 2007.
6. Cable TV forms the backbone of the broadcasting distribution industry and has played a prominent role in the growth of the electronic media sector in the last 20 years.

## NOTES

---

### 10.6 SUMMARY

---

- Prasar Bharati was established following a demand that government owned broadcasters in India should be given autonomy like those in many other countries.
- The Parliament of India passed an Act to grant this autonomy in 1990, but it was not enacted until 15 September 1997.
- The Prasar Bharati Act provides for establishment of a broadcasting corporation, to be known as Prasar Bharati, to define its composition, functions and powers.
- The Prasar Bharati Act grants autonomy to All India Radio and Doordarshan, which were previously under the government control.
- Prasar Bharati Act stipulates that the general superintendence, direction and management of affairs of the Corporation vests in the Prasar Bharati Board, which may exercise all such powers and do all such acts and things as may be exercised or done by the Corporation.
- The All India Radio (AIR) came up as an instrument of establishing and maintaining the British hegemony, but after Independence the radio committed itself to the development programmes of the Government of India and became the most effective media of nation building.
- Keeping in mind the impact and strength of radio, the Government of India launched several projects in the field of education, health care, agriculture, etc.
- Radio has also some inherent limitations which need to be understood and addressed in order to provide effective programmes. Radio as such, is one-way, evanescent and its audience is passive.

## NOTES

- Community radio has a lot of advantages to be the perfect mass communication tool for development communication.
- Television in India began when the Delhi Television Centre came into existence on September 15, 1959. In the beginning this centre used to beam 20 minutes programme twice a week.
- Launched as an experimental satellite communications project in 1975, the Satellite Instructional Television Experiment (SITE) was aimed at providing informational television programme to rural India.
- The INSAT series of domestic communication satellites and microwave cable networks provided India the infrastructure for a national satellite hook-up.
- Telecast technology has undergone a sea change through all these decades. Initially, the technology employed was terrestrial television where the range of the transmitter used to be limited, say only about 50 kilometers.
- DTH service a comparatively recent entrant as compared to cable transmission, has certain technical advantages over cable operations.
- DTH is an addressable system and covers the entire country. In DTH service a large number of television channels are digitally compressed, encrypted and beamed from very high power satellites.
- Cable TV forms the backbone of the broadcasting distribution industry and has played a prominent role in the growth of the electronic media sector in the last 20 years.
- Despite the fast growth of the DTH services, Cable services continue to dominate the distribution of TV channels as of today.
- There are several drawbacks of analogue cable television system including limited carrying capacity, no provision for selection of a-la-carte channels, lack of transparency of subscriber's base, distorted quality of picture.

---

## 10.7 KEY WORDS

---

- **Public Broadcasting:** It refers to television and radio programmes that are broadcast to provide information, advice, or entertainment to the public without trying to make a profit.
- **Community Radio:** It is a radio service offering a third model of radio broadcasting in addition to commercial and public broadcasting.
- **DTH:** It is defined as the reception of satellite programmes with a personal dish in an individual home.
- **INSAT:** It is a series of multipurpose geo-stationary satellites launched by ISRO to satisfy the telecommunications, broadcasting, meteorology, and search and rescue operations.

- **Biotechnology:** It refers to the exploitation of biological processes for industrial and other purposes, especially the genetic manipulation of microorganisms for the production of antibiotics, hormones, etc.

---

## 10.8 SELF ASSESSMENT QUESTIONS AND EXERCISES

---

## NOTES

### Short-Answer Questions

1. Who does the Prasar Bharati board consist of?
2. State the advantages of DTH over cable.
3. What are the drawbacks of an analogue cable television system?

### Long-Answer Questions

1. Explain the functions and objectives of the Prasar Bharati Board.
2. Describe the history of All India Radio.
3. 'Community radio has a lot of advantages to be the perfect mass communication tool for development communication'. Discuss.

---

## 10.9 FURTHER READINGS

---

- Mcquail, Denis. 2013. *Journalism and Society*. New Delhi: Sage Publications.
- Bro, Peter. 2018. *Models of Journalism: The Functions and Influencing Factors*. London: Routledge.
- Burns, Lynette Sheridan. 2002. *Understanding Journalism*. New Delhi: Sage Publications.
- Raghavan, G.N.S. 1994. *Press in India: A New History*. New Delhi: Gyan Publishing House.
- Sharma, K. Suresh. 2006. *Press in India*. New Delhi: Vista International Publishing House.
- Parthasarathy, Rangaswami. 1984. *Basic Journalism*. New Delhi: Macmillan India Limited.

---

## UNIT 11 MASS MEDIA INSTITUTIONS IN INDIA

---

### NOTES

#### Structure

- 11.0 Introduction
- 11.1 Objectives
- 11.2 Government Media Units
  - 11.2.1 Doordarshan
  - 11.2.2 Akashvani
  - 11.2.3 PIB
  - 11.2.4 DAVP
  - 11.2.5 Press Registrar of India
  - 11.2.6 Press Council of India
- 11.3 Answers to Check Your Progress Questions
- 11.4 Summary
- 11.5 Key Words
- 11.6 Self Assessment Questions and Exercises
- 11.7 Further Readings

---

### 11.0 INTRODUCTION

---

In the previous unit, you learnt about the Prasar Bharati Bill, community radio and cable and DTH services in India. In this unit, the discussion will turn towards the mass media institutions in India.

As you have learnt so far, the mass media is a branched out assortment of media technologies that reach a large audience via mass communication. The technologies through which this communication takes place include a variety of outlets including broadcast and digital media. The major institutions of mass media in India are the government institutions such as the Prasar Bharati, All India Radio, as well as the autonomous institutions tasked to regulate press activities such as the Press Council as well as the Press Registrar. This unit will take up these subjects.

---

### 11.1 OBJECTIVES

---

After going through this unit, you will be able to:

- Discuss the various government media units
- Explain the significance of the Press Council of India
- Describe the functions of the Press Registrar of India



---

## 11.2 GOVERNMENT MEDIA UNITS

---

Let us discuss the different media units in India. We have already touched upon them in earlier units.

### 11.2.1 Doordarshan

Over the past couple of decades, if many third-world countries have ventured into the cost-intensive development of independent television networks/systems, it is because they realized the significance of broadcasting in national development. Developing countries required broadcasting to not only be able to establish a sense of national identity but also promote modernization and support related projects and campaigns. In most countries the television was introduced and developed with the middle class in mind, who could also afford to purchase television sets. However, in India, television was introduced with the aim of promoting development.

Doordarshan is the public service broadcaster in India and functions under the aegis of an autonomous body called the Prasar Bharti. In fact, it is one of the largest broadcasting organizations in the world with reference to its infrastructural capacity. Doordarshan celebrated its golden jubilee (50 years since inception) in the year 2009.

Experimental television programmes of Doordarshan began in 1959. SITE (Satellite Instruction Television Experiment) of 1975–76 was a very prominent project. However, Doordarshan became immensely popular after television became a mass medium in the country in the 1980s. The factors that spurred this development included:

- (i) Commercialization of Doordarshan
- (ii) Focus on entertainment as a result of commercialization
- (iii) Development of a national network of transmitters linked with satellite technology
- (iv) Economic reforms that resulted in the availability of television sets at lower rates

There was a virtual monopoly of the state-controlled Doordarshan till the early 1990s. Doordarshan's reach had increased from 26% in 1982 to 80% in 1991. Currently, Doordarshan (DD) runs exclusive channels that provide entertainment, sports and news. There are also several educational and regional channels.

### 11.2.2 Akashvani

The pioneers of broadcasting in India were the amateur radio clubs in Calcutta (now Kolkata), Madras (now Chennai), Bombay (now Mumbai) and Lahore after several experimental broadcasts were conducted in Bombay and other cities.

## NOTES

## NOTES

The Radio Club of Calcutta was the first amateur radio club to start functioning in November 1923. Madras Presidency Radio Club came close on its heels in May 1924 and began broadcasting in July. The clubs came together because of financial crunch to form Indian Broadcasting Company Ltd. (IBC) in 1927. This was a private company on the lines of European Broadcasting. The IBC built two weak little stations at Calcutta and Bombay. Within three years, the company had as many as 7000 listeners. However, due to lack of revenue it lost a great deal of money and decided to go into liquidation. There was no support from the government. At the last moment BBC started an Empire programme on the short wave. There was a sudden rush from Europeans to buy radio sets to be able to listen to this programme and 8000 sets were purchased in bulk after imposing a 15 per cent import duty on them.

The government-run broadcasting was set up and was named as Indian State Broadcasting Service (ISBS). Lionel Fielden was made its first controller. It was his idea to rename this service as All India Radio (AIR).

### **AIR after Independence**

When British Raj ended in 1947, All India Radio had a small network of six stations. There were 2.5 lakh receiving sets which meant one set for every 12500 persons in the country. This would hardly characterize the organization as a mass communication system; and among the available mass media radio was the only channel that had the potentiality to be quickly developed into an effective and truly national service. That was particularly the case, since the reach of the printed word was limited as only about 30 per cent of the population was literate and 80 per cent lived in villages. So out of necessity, the quick development of the radio became the policy of the planners and the government under the successive five year plans.

AIR came to be known as Akashvani in 1957. Since then it has emerged as the biggest media organization of the central government, with its programmes received by over 3 crore radio receiver sets in India. As a fast and instantaneous communication medium, it has an in built advantage of overcoming the country's formidable literacy, linguistic, cultural and physical barriers. It could also involve different types of people and integrate various kinds of cultural, musical, dance and folk art forms that are found in India. During the British period this was not possible because the alien government had little respect for national aspirations as also for an indigenous form of entertainment. After independence this attitudinal obstacle ended.

Luckily, AIR had experienced personal and 'its innovative zeal was unbounded.' For example, in 1948 AIR Bombay arranged to interview the Hollywood Greer Garson through an intercontinental link arranged by the Post and Telegraph department. In fact, that spirit had infused largely the software policy of AIR. Accordingly, the main thrust of its programmes was on putting out

need – based innovative programmes. In addition, that was the requirement of the time after the communal bloodbath of partition, the urgency of emotional integration after the reorganization of states and initiation of the process of integrated planning. The programme advisory committees set up at various stations and guidelines evolved in August 1980 too have sought to inject a high spirit of professionalism in broadcasting programmes and to make them more receptive to constructive criticism. To this end, listeners' letters, regular feedback service, and analysis of listeners' reactions by audience research units to the programmes broadcast have also made significant contribution.

The manifestation of the spirit of innovativeness was evident when AIR covered sports events during Asiad 1982. In fact, it proved to be a landmark coverage. AIR broadcasted the various events to listeners all over the country. It also furnished facilities for dubbing and relaying the events to foreign broadcasting organizations. A team of nearly 550 people consisting of programmers, engineers and technicians were placed on duty in different stadia to catch the events in sound and convey them to listeners. All the technical infrastructure required for this historic event was provided internally.

### **Diversified Programmes of AIR**

Over the years, All India Radio has expanded its range of programming. Today its home service programmes are transmitted for 3.91 lakh hours every year, excluding 1.76 lakh hours of Vividh Bharati programmes. Further, All India Radio also presents programmes in seventeen different foreign languages and eight Indian languages for over 56 hours daily on its external service to listeners aboard so as to present India's point of view on important issues.

Radio is considered to be the music box for the common man. Previously, music, particularly, Indian classical music was considered to be the reserve of the rich. Due to the radio, different kinds of Indian music, whether they are classical, folk, film based, tribal, devotional, and so on can be enjoyed by anyone who owns a radio. Studies show that radio stations spend about 40 per cent of their total broadcasting time to programmes related to music. Thus, it can be said that All India Radio is facilitating the protection of the Indian musical heritage by acquainting the younger generation with the Indian classical music tradition.

AIR is seeking to scout new talents continually through regular music auditions as well as annual music competitions. Young and promising artists of higher grades are regularly featured in public concerts as well as in zonal hook up programmes. Classical music programmes comprise a weekly national programme of music which presents to the nation music by leading practitioners of both Hindustani and Karnataka schools of music. As a promotional measure, a festival of music, known as radio sangeet sammelan is also organized every year. The recordings of these concerts are broadcast on AIR's network in the country. One of the significant achievements of AIR's national programmes in music as also of radio sangeet

## **NOTES**

## NOTES

sammelan is integration through the interaction of the two major styles of Indian music. Eminent artists as well as the more promising younger talents in both styles are presented in these programmes which are beamed on the national network.

Since 1973, it also broadcasts a national programme of regional music, which brings to the listeners the rich tradition of folk and the light music of various regions. Besides, AIR stations put out sizeable chunks of folk and light music in their programmes. In 1952, it started the orchestral programme called 'vadyavrinda' consisting of both Hindustani and Karnataka instrumentalists. The Delhi unit has done remarkable experiments in orchestration of Indian music and has wide repertoire of a variety of compositions based on traditional ragas and fold tunes. The madras unit comprised mainly Karnataka musicians. AIR is also paying equal attention to the development of folk light and choral music.

Even today, discerning people like to listen to radio news bulletins for they attempt to give comprehensive and speedy coverage of news and views in addition to commentaries and discussions on current affairs. Besides focusing on major trends in political, economic, social, cultural and scientific fields they give adequate attention to rural development, parliamentary proceedings and sports activities. News is broadcast daily through 254 bulletins. Of these, 68 bulletins in 19 languages are beamed from the home service from Delhi, 123 original bulletins in 60 languages and dialects and 63 bulletins of external services in 24 languages. Specialized news, sports news, state and development news, slow speed bulletins in English, Hindi and Urdu, a weekly bulletin of human interest stories constitute other important bulletins of AIR covered by its own correspondents. In days when parliament is in session, daily commentaries in English and Hindi review the day's proceedings in the two Houses. Since 1977, a weekly coverage has also been introduced. A similar coverage of state legislatures is broadcast for state capitals in the languages concerned.

The external services broadcasts are designed to project a true and objective image of the country to listeners abroad. They explain the country's point of view on matters of national and international importance. They also seek to acquaint listeners with the ideas and achievements of India as an open society, as also its secular ideals. These broadcasts are equally significant to service as a link with people of Indian origin living or settled abroad.

AIR beams programmes for special audiences and occasions. Specific programmes are relayed for the armed forces, women and children, youth, students, industrial workers, rural and tribal people. 14 stations broadcast daily programmes for the armed forces. Almost 55 stations present programmes twice a week in original languages for women. The objective of these programmes is to provide entertainment and impart necessary information on household topics. Programmes on family welfare, a very important sector of human progress are planned and produced by 36 family welfare units at various stations of the broadcasting network. These programmes are integrated with the general programmes as well as those meant for the special audiences like rural, folk, women, youth and industrial workers.

The early sixties saw a vast growth in rural broadcasting. Auxiliary transmitting centres were installed to extend the coverage of the existing station. Farm and home units were created at several stations. By 1965, every station of AIR started broadcasting special programmes especially for rural listeners for about 30 to 75 minutes on a daily basis. Besides, a daily programme on hardcore agriculture and weather reports are broadcast for 45 to 55 minutes from 64 farm and home units, located in different AIR stations. These programmes aimed at providing educational and informational support to the intensive agricultural and rural development programmes. They also seek to disseminate new agricultural technology to farmers in their local languages or dialects, besides covering other subjects like rural cooperation, animal husbandry, poultry, fisheries and cottage industries. 31 stations present specially conceived and cooperatively developed programmes called the 'farm school of AIR' where instruction and guidance on farming is provided to listeners. In this programme, lessons on subjects like rice and wheat cultivation use of fertilizers, dairy, poultry, fisheries and nutrition are given. The evaluation of these programmes has indicated that the audience finds them extremely useful. It is interesting to learn from the record projects of agricultural universities that AIR's rural programmes are not only useful to the villagers but also command credibility and acceptability. The imprint of AIR is best known by the terms — radio seeds and radio fertilizers.

In order to provide a forum for the self-expression of the youth between the age of 15 to 30 years, AIR broadcasts a programme for youth called 'yuvavani' from 74 stations. This service provides an opening for the talents of this age group to present their viewpoints by participating in a wide range of programmes, talks, discussions, interviews, plays, features and music. Under these programmes a youth news bulletin is also broadcast by the youths.

AIR is an extensive arm of India's cultural activities. Its programmes include at least two plays a week. Besides, original plays, radio adaptations of outstanding stage plays, novels and short stories are also broadcast. Since 1956 outstanding plays from Indian languages are being transmitted in the national programme of plays. The national programme of features which commenced in 1956 focuses attention on matters of national importance or interest in political, economic, social or cultural spheres. In fact, many people with a literary bent of mind lay great emphasis on AIR's literary and cultural programmes and draw mental exhilaration from them.

AIR is becoming a good aid in school education. Most AIR stations broadcast programmes based on the school curriculum to reach students in interior areas. Radio support to university correspondence degree courses is also provided by several stations.

Sports events in India and abroad are covered by reviews, running commentaries and voice dispatches. In metropolitan centres a daily sports service is put for 95 minutes covering all important sports events. In addition, two news

## NOTES

## NOTES

bulletins, one in English and other in Hindi, of five minutes duration, and weekly sports newsreels are also broadcast.

There are special occasions which attract special programmes on the national hook up of AIR. These include the Republic day, Independence Day, anniversaries, visits of foreign dignitaries or the visits of Indian dignitaries abroad.

Radio is a popular entertainer as well. Vividh Bharati, a popular broadcast for this purpose is transmitted from 31 centres including two short wave transmitters at Mumbai and Chennai. The total duration of Vividh Bharati is 12 hours and 45 minutes on week days and 12 hours and 15 minutes on Sundays and holidays. The programmes which are generally acclaimed are music, humorous skits, short plays and features.

AIR introduced broadcasting of commercials on November 1, 1967. That is a part of marketing service, through it brings revenue as well. Today the service is provided by 28 centres. Advertisements are accepted in any language as tape recorder spots of 7, 15, 30 and 60 seconds duration.

Radio as a mass media tool and the concept 'radio for all' will be roughly measured in terms of the number of radio receiving or transistor sets in the country. Since independence these sets have increased manifold to an aggregate of around 3 crores. The number may increase with the lifting of licence fee this year. In terms of diffusion rate it means nearly 4.4 sets for 100 persons. Still a figure below the minimum UNESCO norm of 5 sets for 100 people or one set for each family. In the Indian context, however, the redeeming situation is that one set can be used to serve a larger number of people beyond the household. In addition, there are about 1.6 lakh community sets which operate in rural areas. Although the transistor revolution which has swept every part of the country has reduced the importance of community sets, some recent studies have underlined the need of continuing to have community receiver sets at least in selected areas. In the sixties, when the community listening scheme was in full swing and assessed, it was revealed that the discussions in community listening and deliberations were excellent or good and that participants learnt a 'great deal' or quite a lot.' also In addition, these forums developed rapidly into decision-making bodies capable of speeding up common pursuits of the village.

The government's interest in radio and its concern about its growth were reflected in the allocations to broadcasting in its successive five year plans. As a result AIR grew in size and status. Today this national service comprises 86 stations including two Vividh Bharati commercial centres, one at Chandigarh and other at Kanpur. In addition, the network includes two auxiliary study centres at Bhubaneswar and Shantiniketan.

AIR's programmes are beamed from 162 transmitters of which 126 are medium dash wave. Broadly speaking we may say that AIR now serves about 90 per cent of population and about four-fifths of the total area of the country. More than any other media, its sweep includes far flung areas like Leh and Laddakh,

Tawang in Arunachal Pradesh and the distant islands like the Andaman and Nicobar and the Lakshadweep. One may hope that it is not in the distant future that AIR may reach its full moon day by claiming to cover all the areas of the country and its entire population.

Simultaneously, AIR has also staged a leap forward in its software and research development aspect. Today it does face occasional fireworks or adverse comments of critics. It also has an intrinsic weakness of not enjoying high credibility because of its being a government controlled medium. Yet, AIR is considered by media authorities and researchers to have proved its worth and utility both as an informational channel and a development and cultural activist. Still more, it has provided healthy entertainment through its various light and humorous programmes. Extension research and other field surveys have already given great credit to radio both as a credible promoter of suitable climate for development and progress and also for having advanced farm educational and cultural renaissance. Its contribution in the form of transmitting useful and timely information, motivation and suggestions for rural development is conceded. Its sponsors claim that radio is helping to create a climate of opinion in which social change can take place and people could be involved in the process. One can safely presume that along with TV, documentaries and farms journals, AIR will provide an adequate communication umbrella to integrated rural broadcast, feedback interviews, 'meet the activists and innovators' and critic series, impact studies and others. Thus, AIR has an activating role in furthering India's culture, education, music and other practising arts. The increasing number of Walkman transistors and the growing popularity of listeners' letters are obvious indications.

### 11.2.3 PIB

The Press Information Bureau (PIB) is the nodal agency of the Government of India to disseminate information to the print and electronic media on its various policies, and programmes. The organization is headed by the Principal Information Officer. There are eight regional offices and thirty-five branch offices for disseminating information. The Bureau at the headquarters has a team of officers attached to various Ministries and Departments for the purpose of assisting them in the management of the media and public relations. The PIB acts as an interface between the government and the media and the Information Officers serve as official spokesmen for the government.

The Press Information Bureau functions as an interface between the government and the media and also serves to provide feedback to the government on people's reaction as reflected in the media.

PIB disseminates information through different modes of communication viz. press releases, press notes, feature articles, backgrounders, photographs, database available on Bureau's website. Information disseminated is released in English, Hindi and Urdu and subsequently translated in other Indian languages to reach out to about 8,400 newspapers and media organizations in different parts of country.

## NOTES

## NOTES

In addition PIB organizes Press Conferences, Press Briefing, Interviews of the Minister's /Secretary's and other senior officers for sensitizing media persons on important policy initiatives of the Government. The Bureau also conducts Press Tours to successful project sites to enable media to have firsthand account of developmental activities going on in the country.

PIB has eight Regional Offices headed by Additional Director Generals and 34 Branch Offices and Information Centers to cater to information needs of regional press and other media. In addition to release of publicity material issued from the Headquarters in local language, these Regional and Branch Offices of PIB issue original press releases, press notes, backgrounders etc. whenever an important event is organized by any of the Central Ministries or Public Sector Undertakings in a particular region. These Offices also take up the decisions of the Central Government which may be of special importance to a particular region for focused publicity through information dissemination on sustained basis.

Activities of PIB can be broadly classified in three Categories viz. Information, Education & Communication (PUBLICITY), Feedback, Accreditation & Special Services Departmental Publicity Officers (DPOs) have been attached to various Ministries and Departments for disseminating information to the media through press releases, press notes, backgrounders etc. and also by arranging press conferences, press tours, media briefings etc., These Officers have been consistently providing the requisite service to their respective Ministries and have been also meeting the information needs of media in respect of those Ministries. DPOs also advise their respective Ministries on all matters pertaining to information needs of media and Ministries' publicity requirements.

Beside the routine publicity work, the Bureau makes some special endeavours towards publicity like Editors Conference on Social and Infrastructure Issues, Economic Editors' Conference (EEC) PICs and Press Tours.

Public Information Campaigns (PICs) are organized as information camps in collaboration with DAVP, DFP, S&DD etc. to provide information to common people on various schemes of the Central Govt. The strategy of a PIC is to combine information dissemination with the delivery of services at the doorsteps for the beneficiaries particularly in rural areas. It envisages direct contact with the 'Aam Aadmi' and seeks to empower citizen particularly from rural areas with knowledge of various welfare schemes of Central Govt. under the flagship programmes.

Bureau's officers attached to various Ministry/Departments also provide feedback to their respective Ministries and Departments. As part of the Special Services, the Feedback Cell in PIB prepares Daily Digests and Special Digests based on news stories and editorials from National as well as Regional dailies and periodicals for the use by Ministries. The Feature Unit of the Bureau issues backgrounders, updates, info-nuggets, features and graphics, which were also sent to the Regional/Branch offices for translation and circulation to the local media.



The PIB provides accreditation to media representatives including foreign media at the Headquarters. This facilitates them to access information from the Government sources. The number of media persons accredited is 1618 correspondents and 476 cameramen/photographers. Besides, 152 technicians and 84 editors and media critics have also been granted accreditation. The Bureau has adopted a fully online system of accreditation from the year 2009.

#### 11.2.4 DAVP

The Directorate of Advertising and Visual Publicity (DAVP) is the nodal agency to undertake multi-media advertising and publicity for various ministries and departments of the Government of India. Some of the Autonomous Bodies also route their advertisements through DAVP. As a service agency, it endeavours to communicate at grass roots level on behalf of various Central Government Ministries.

Immediately after the outbreak of World War II, the erstwhile Government of India appointed a Chief Press Advisor. Besides other things, advertising was also the responsibility of the Chief Press Advisor. A post of Advertising Consultant was created in June 1941 under the Chief Press Advisor. This is where DAVP has its roots. On March 1, 1942, the Advertising Consultant Office became the Advertising Branch of the Department of Information & Broadcasting. Following the expansion in its scope, functions and activities, this Advertising unit was declared an Attached Office of the Ministry of Information & Broadcasting on October 1, 1955. The office also assumed the name of Directorate of Advertising & Visual Publicity (DAVP).

DAVP has been working as a catalyst of social change and economic growth over the years. It has been instrumental in creating awareness amongst masses on socio-economic themes, seeking their participation in developmental activities and for eradication of poverty and social evils.

- To perform the functions of a multi-media advertising agency for the Central Government.
- To act as service agency for Central Government ministries/departments to meet their publicity needs including production of media inputs as well as dissemination of messages/information.
- To help Central Government departments in formulating communication strategies/media plans and help implement them at the grass-root level by providing multi-media support.

There are many channels of communication used by DAVP for the publicity like advertisements (Release of press ads), exhibitions, outdoor publicity (display of hoardings, kiosks, bus panels, wall paintings, cinema slides, banners etc.), printed publicity (booklets, folders, posters, leaflets, calendars, diaries etc.), audio & visual publicity (spots/quickies, jingles, sponsored programmes, short films etc.) and mailing of publicity material (distribution of publicity material).

## NOTES

## NOTES

DAVP has a network of offices spread all over the country. DAVP has two Regional Offices at Bangalore and Guwahati to coordinate the Directorate's activities in the region. Besides it has two Regional Distribution Centres at Calcutta and Chennai look after distribution of publicity material in eastern and southern regions, respectively. It also has 35 Field Exhibition Units which include seven mobile exhibition vans, seven family welfare units and 21 general field exhibition units, Regional Exhibition Workshop at Chennai and Exhibition Kit Production Centre at Guwahati assist the Exhibition Division at headquarters in designing and fabricating exhibits.

Some of the important subjects publicised by DAVP include Health & Family Welfare, Drug Abuse & Prohibition, Women & Child Development, Upliftment of Girl Child, Education, Adult Education, Non-Conventional Energy Sources, Mahila Samridhi Yojana, National Integration & Communal Harmony. It has also prepared campaigns on Creating public opinion against dowry, female infanticide, child labour, beggary, Blood Donation, AIDS Awareness, Consumer Protection, Safe Drinking Water, Welfare of the Handicapped, Water-Borne Diseases along with many others like Handicrafts, Social Welfare Programmes, Agriculture, Food & Nutrition, TRYSEM, Integrated Rural development project (IRDP), DWCRA, Employment Assurance Scheme, Jawahar Rozgar Yojana and Panchayati Raj.

### 11.2.5 Press Registrar of India

Printing and publishing of newspapers and periodicals within India are governed by the Press and Registration of Books Act, 1867 and the Registration of Newspapers (Central) Rules, 1956.

According to the Act, no newspaper or periodical should bear a title which is the same or similar to any other newspaper or periodical already being published, either in the same language or in the same State, unless the latter is also owned by the same person.

In order to ensure compliance of this condition, the Government of India has appointed the Registrar of Newspapers, also called the Press Registrar, who maintains a register of newspapers and periodicals published in India.

The Office of the Registrar of Newspapers for India is headquartered in New Delhi, and has three regional offices at Calcutta, Mumbai and Chennai to cater to the needs of publishers in all corners of the country. The Press Registrar is assisted by a Deputy Press Registrar and four Assistant Press Registrars (one each at the headquarters and the regional offices). There is also a Senior Circulation Officer and five Circulation Officers two at headquarters and one each in the regional offices to assist the Press Registrar in assessing the circulation claims of newspapers.

### 11.2.6 Press Council of India

The basic concept of self-regulation in which the Press Councils and similar media bodies world over are founded, was articulated by Mahatma Gandhi, who was an

eminent journalist in his own right and said, 'the sole aim of journalist should be service. The newspaper press is a great power, but just as unchained torrent of water submerges the whole country side and devastates crops, even so an uncontrolled pen serves but to destroy. If the control is from without, it proves more poisonous than want of control. It can be profitable only when exercised from within.'

The Commission that led to the establishment of the Press Council stated that the Council should consist of individuals who would command general confidence and respect of the profession and should have twenty-five members, excluding the chairman. The chairman was to be a person who was, or had been a judge of the High Court, and was to be nominated by the Chief Justice of India.

The Press Council of India was first constituted on 4 July 1966 as an autonomous, statutory, quasi-judicial body, with Shri Justice J.R. Mudholkar, then a Judge of the Supreme Court, as the chairman. The Press Council Act, 1965, listed the following functions of the Council in furtherance of its objects:

1. To help newspapers maintain their independence
2. To build up a code of conduct for newspapers and journalists in accordance with high professional standards
3. To ensure on the part of newspapers and journalists the maintenance of high standards of public taste and foster a due sense of both the rights and responsibilities of citizenship
4. To encourage the growth of a sense of responsibility and public service among all those engaged in the profession of journalism
5. To keep under review any development likely to restrict the supply and dissemination of news of public interest and importance
6. To keep under review such cases of assistance as received by any newspaper or news agency in India from foreign sources, as are referred to it by the Central Government

Provided that nothing in this clause shall preclude the Central Government from dealing with any case of assistance received by a newspaper or news agency in India from foreign sources in any other manner it thinks fit

1. To promote the establishment of such common service for the supply and dissemination of news to newspapers as may, from time to time, appear to it to be desirable
2. To provide facilities for the proper education and training of persons in the profession of journalism
3. To promote a proper functional relationship among all classes of persons engaged in the production or publication of newspapers
4. To study developments which may tend towards monopoly or concentration of ownership of newspapers, including a study of the

## NOTES

## NOTES

ownership or financial structure of newspapers, and if necessary, to suggest remedies therefore

5. To promote technical or other research
6. To do such other acts as may be incidental or conducive to the discharge of the above functions

The Act of 1965 provided that the Council shall consist of a Chairman and twenty-five other members. Of the twenty-five members, three were to represent the two houses of Parliament; thirteen were to be from the working journalists, of which not less than six were to be editors who did not own or carry on the business of management of newspapers; and the rest were to be the persons having special knowledge or practical experience in respect of education and science, law, literature and culture. By an amendment of the Act in 1970, the membership of the Council was raised by one to provide a seat for persons managing the news agencies.

The Chairman under the Act on 1965 was to be nominated by the Chief Justice of India. Of the three Members of Parliament, two representing Lok Sabha were to be nominated by the Speaker of the Lok Sabha; and one representing Rajya Sabha, was to be nominated by the Chairman of the Rajya Sabha. The remaining twenty-two members were to be selected by a selection committee comprising the Chief Justice of India, Chairman of the Press Council and a nominee of the President of India. The Chairman and the members were to hold office for a period of three years, while providing that no member could hold office for a period exceeding six years in the aggregate.

As has been referred to earlier, the composition of the nominating committee was changed by an amendment of the said Act in 1970, according to which the chairman and the members from the Press were to be nominated by a nominating committee consisting of the Chairman of the Rajya Sabha, the Chief Justice of India and the Speaker of the Lok Sabha.

The nominating committee was empowered to review any nomination on a representation made to it by any notified association, or by any person aggrieved by it or otherwise. The amended Act also prohibited the re-nomination of a retiring member for more than one term. Where any association failed to submit a panel of names when invited to do so, the nominating committee could ask for panels from other associations, or persons of the category concerned, or nominate members after consultation with such other such individuals or interests concerned as it thought fit.

Under the original Act, the chairman was nominated by the Chief Justice of India. But, after this amendment, the nomination of the chairman was also left to the nominating committee.

The new Act provides for selection of the chairman by a committee consisting of the Chairman of the Rajya Sabha, the Speaker of Lok Sabha and a person elected by the members of the Council from among themselves. The twenty

representatives of the Press are nominated by the associations of aforesaid categories of the newspapers and news agencies notified for the purpose by the Council in the each category. One member each is nominated by the University Grants Commission, the Bar Council of India and the Sahitya Academy. Of the five Members of Parliament, three are nominated by the Speaker of the Lok Sabha and two by the Chairman of the Rajya Sabha. The term of the chairman and the members of the Council is three years. A retiring member is eligible for re-nomination for not more than one term.

An extremely healthy feature of the Indian Press Council is the scheme and procedure of the nomination of its chairman and other members, following a long search based on the experience of several years of functioning of the Council. Despite being a statutory body, the government and its authorities have been completely kept out of the nomination process except for publishing the notification in the official gazette of the names of the members nominated. Nor has it been left to any individual to decide, however eminent or highly placed he may be.

A totally non-subjective procedure which leaves no scope for the interference or influence by government or any other agency was evolved with remarkable ingenuity. The scheme is in force since the enactment of the Press Council Act of 1978 under which the revived Press Council was set up in 1979.

## NOTES

### Check Your Progress

1. What is Doordarshan?
2. Who were the pioneers of broadcasting in India?
3. What is the Press Information Bureau?
4. What Acts govern the printing and publishing of newspapers and periodicals?

---

## 11.3 ANSWERS TO CHECK YOUR PROGRESS QUESTIONS

---

1. Doordarshan is the public service broadcaster in India and functions under the aegis of an autonomous body called the Prasar Bharti.
2. The pioneers of broadcasting in India were the amateur radio clubs in Calcutta (now Kolkata), Madras (now Chennai), Bombay (now Mumbai) and Lahore after several experimental broadcasts were conducted in Bombay and other cities.
3. The Press Information Bureau is the nodal agency of the Government of India to disseminate information to the print and electronic media on its various policies, and programmes.

4. Printing and publishing of newspapers and periodicals within India are governed by the Press and Registration of Books Act, 1867 and the Registration of Newspapers (Central) Rules, 1956.

## NOTES

### 11.4 SUMMARY

- Over the past couple of decades, if many third-world countries have ventured into the cost-intensive development of independent television networks/systems, it is because they realized the significance of broadcasting in national development.
- Developing countries required broadcasting to not only be able to establish a sense of national identity but also promote modernization and support related projects and campaigns.
- Doordarshan is the public service broadcaster in India and functions under the aegis of an autonomous body called the Prasar Bharti.
- The Radio Club of Calcutta was the first amateur radio club to start functioning in November 1923.
- The government-run broadcasting was set up and was named as Indian State Broadcasting Service (ISBS). Lionel Fielden was made its first controller. It was his idea to rename this service as All India Radio (AIR).
- Even today, discerning people like to listen to radio news bulletins for they attempt to give comprehensive and speedy coverage of news and views in addition to commentaries and discussions on current affairs.
- The government's interest in radio and its concern about its growth were reflected in the allocations to broadcasting in its successive five year plans.
- The Press Information Bureau functions as an interface between the government and the media and also serves to provide feedback to the government on people's reaction as reflected in the media.
- The Directorate of Advertising and Visual Publicity (DAVP) is the nodal agency to undertake multi-media advertising and publicity for various ministries and departments of the Government of India.
- Printing and publishing of newspapers and periodicals within India are governed by the Press and Registration of Books Act, 1867 and the Registration of Newspapers (Central) Rules, 1956.
- The Office of the Registrar of Newspapers for India is headquartered in New Delhi, and has three regional offices at Calcutta, Mumbai and Chennai to cater to the needs of publishers in all corners of the country.

- The Press Council of India was first constituted on 4 July 1966 as an autonomous, statutory, quasi-judicial body, with Shri Justice J.R. Mudholkar, then a Judge of the Supreme Court, as the chairman.
- An extremely healthy feature of the Indian Press Council is the scheme and procedure of the nomination of its chairman and other members, following a long search based on the experience of several years of functioning of the Council.

## NOTES

---

### 11.5 KEY WORDS

---

- **Pioneers:** It refers to people who are the first to develop or be the first to use or apply a new method, area of knowledge, or activity.
- **Self-regulation:** It refers to the controlling of a process or activity by the people or organizations that are involved in it rather than by an outside organization such as the government.
- **Compliance:** It means the action or fact of complying with a wish or command.
- **Advertising:** It is the activity or profession of producing advertisements for commercial products or services.
- **Publicity:** It refers to the giving out of information about a product, person, or company for advertising or promotional purposes.

---

### 11.6 SELF ASSESSMENT QUESTIONS AND EXERCISES

---

#### Short-Answer Questions

1. Write a short-note on Doordarshan.
2. What is the role of the Press Information Bureau?
3. List the objectives of the Directorate of Advertising and Visual Publicity.
4. What is the role performed by the Office of the Registrar of Newspapers?

#### Long-Answer Questions

1. Describe the different government media units in India.
2. Discuss how Akashvani has emerged as the biggest media organization of the central government.
3. Discuss the history and programming of All India Radio after independence.
4. Examine the functions of the Press Council of India.

---

## 11.7 FURTHER READINGS

---

### NOTES

- Mcquail, Denis. 2013. *Journalism and Society*. New Delhi: Sage Publications.
- Bro, Peter. 2018. *Models of Journalism: The Functions and Influencing Factors*. London: Routledge.
- Burns, Lynette Sheridan. 2002. *Understanding Journalism*. New Delhi: Sage Publications.
- Raghavan, G.N.S. 1994. *Press in India: A New History*. New Delhi: Gyan Publishing House.
- Sharma, K. Suresh. 2006. *Press in India*. New Delhi: Vista International Publishing House.
- Parthasarathy, Rangaswami. 1984. *Basic Journalism*. New Delhi: Macmillan India Limited.



---

**BLOCK - IV**  
**INDIAN NEWS AGENCIES AND ITS STATUS**  
**IN INDIA**

---

*Media Agencies,  
Organizations and  
Institutions*

**NOTES**

---

**UNIT 12 MEDIA AGENCIES,  
ORGANIZATIONS AND  
INSTITUTIONS**

---

**Structure**

- 12.0 Introduction
- 12.1 Objectives
- 12.2 Indian News Agencies
- 12.3 Professional Media Organizations
- 12.4 Media Educational Institutions
- 12.5 Answers to Check Your Progress Questions
- 12.6 Summary
- 12.7 Key Words
- 12.8 Self Assessment Questions and Exercises
- 12.9 Further Readings

---

**12.0 INTRODUCTION**

---

In the previous unit, you learnt about different mass media institutions in India as well as government media units and the press council. Here, we will discuss different news agencies in India. We will also discuss professional organizations related to the media. A news agency is basically an organization that gathers news reports and sells them to subscribing news organizations, such as newspapers, magazines and radio and television broadcasters. A news agency may also be referred to as a wire service, newswire, or news service. In India there are essentially three news agencies in India, ANI, PTI and IANS. The unit will also discuss media educational institutions.

---

**12.1 OBJECTIVES**

---

After going through this unit, you will be able to:

- Discuss the various news agencies and media educational institutions in India
- Describe the different professional media organizations in India

## NOTES

---

## 12.2 INDIAN NEWS AGENCIES

---

News agencies refer to organizations who are involved in the process of gathering, writing and distributing news to different newspapers, radio, government agencies, periodicals, or other such audience. They are also known by the name of wire service, press association, press agencies, or news service. The following are some of the Indian news agencies:

### PTI

Press Trust of India (PTI) is India's premier news agency, having a reach as vast as the Indian Railways. It employs more than 400 journalists and 500 stringers to cover almost every district and small town in India. Collectively, they put out more than 2,000 stories and 200 photographs a day to feed the expansive appetite of the diverse subscribers, who include the mainstream media, the specialised presses, research groups, companies, and government and non-governmental organisations.

PTI correspondents are also based in leading capitals and important business and administrative centres around the world. It also has exchange arrangements with several foreign news agencies to magnify its global news footprint.

Currently, PTI commands 90 per cent of new agency market share in India.

PTI was registered in 1947 and started functioning in 1949. Today, after 65 years of its service, PTI can well and truly take pride in the legacy of its work, and in its contribution towards the building of a free and fair Press in India. On its golden jubilee in 1999, President K R Narayanan said, 'We got independence in August 1947. But independence in news and information we got only with the establishment of PTI in 1949. That is the significance of PTI...'

PTI is run by a Board of Directors with the Chairmanship going by rotation at the Annual General Meeting. The day-to-day administration and management of PTI is headed by the Chief Executive Officer.

### IANS

With India's growing importance in international strategic and economic thinking, news about the country is becoming more critical to the world. IANS (Indo-Asian News Service) provides news and analyses from India and South Asia from the region's perspective.

IANS was established in 1986, initially to serve as an information bridge between India and its thriving Diaspora in North America.

Three decades later, it is a full-fledged wire agency, putting out news 24x7 from India and South Asia, and covering events of interest to this region from around the world.

IANS is, however, more than just India's largest independent news service. It is now the preferred source for all manner of content and information.

A media powerhouse, IANS is divided into six business verticals: IANS News Service (English & Hindi), IANS Multimedia, IANS Publishing, IANS Media Consultancy, IANS Software Services, IANS Mobile Services. Each vertical is headed by a distinguished professional with strong domain expertise.

The IANS client list includes practically every major print publication in India, top television news channels, websites, mobile operators, ethnic publications abroad, central and state government ministries and departments, overseas Indian missions, corporates and public policy institutions.

IANS is today one of India's most reliable, independent and professional news wholesalers, providing high quality content across all media platforms.

### **ANI**

Founded over 50 years ago, ANI (Asian News International) is today South Asia's leading multimedia news agency with over 100 bureaus in India, South Asia and across the globe. ANI's growth has been fuelled by the desire to fulfil the basic human need for knowledge and information, and they have done so with truth, credibility, quality and speed as their guiding principles.

To cater to the ever-increasing spectrum of demand for news and information in an era of rapidly evolving technologies, ANI's pursuit of excellence sees it ever innovating, improving and redesigning our products and services.

As South Asia's leading Multimedia News Agency, and one of the best professionally managed corporate media entities of the world, ANI has a big reputation to live up to. They are in a race with time every minute of the day and every day of the year, to deliver to their multitude of clients- television channels, radio stations, newspapers, websites and mobile carriers, both at home and abroad, the best possible video/audio, text and picture content.

#### **Check Your Progress**

1. When was the Press Trust of India registered?
2. What are the different verticals of IANS?

---

## **12.3 PROFESSIONAL MEDIA ORGANIZATIONS**

---

Let us discuss the different professional media organizations in India.

### **INS**

The early beginnings of the Indian Newspaper Society can be traced back to October 11, 1927, when a Society bearing the name, The India, Burma & Ceylon Newspapers' London Committee came into being, the name of which was changed to Indian & Eastern Newspaper Society (IENS) on October 4, 1935. This was

## NOTES

an organization based in London representing and acting solely under the authority of newspapers, magazines, reviews and other journals published in India, Burma, Ceylon and other countries of Asia.

The need, however, was felt for the establishment of a co-ordinating body in this country, comprising the proprietors of newspapers, which could deal directly and more expeditiously with the various day-to-day problems arising out of newspaper production. Thus The Indian & Eastern Newspaper Society came into being.

The objective of the Society which may be enlarged at any time as herein after provided are:

- To act as a central organization of the Press of India. and of any other country in Asia, which desires to associate itself with the Society.
- To promote and safeguard the business interests of its members incidental to the production of their publications and to take suitable steps in respect of such business as are affected by the action of Legislatures, Governments, the Law Courts, Municipal and local bodies and Associations or Organizations, commercial or formed for any other purpose.
- To collect information upon all topics having a practical business interest for its members and to communicate the same to them.
- To promote co-operation in all matters affecting the common business interests of members.
- To hold periodical conferences of its members to discuss and determine action on matters of common business interest.
- To make rules and regulations and bye-laws to govern the conduct of its members in accordance with the decisions of the Society, to provide penalties for the infringement thereof and to provide means of determining whether there has been such infringement.
- To maintain a permanent secretariat in India to watch over the business interests of members and to permit of a constant interchange of information and views.
- To invest and deal with the assets of the Society in such manner as may from time to time be determined by the Committee of the Society and to operate Current or Fixed Deposit Accounts with any Bank or Banks or in Government Securities as approved by the Committee.
- To subscribe, become a member of or otherwise co-operate with any other Association whose objects are wholly or in part similar to those of the Society.
- To collect subscriptions and other contributions from its members for the recurring and incidental expenses of the Society.

- To undertake any arbitration for settlement of general or special disputes arising between members of the Society.
- To provide for the grant of any pension, gratuity, allowances bonus or other payment to or for the benefit of the employees of the Society as deemed expedient whether they have or have not a legal claim upon the Society for such grants.
- To borrow or raise or secure the payment of money which may be required for the purposes of the Society in such manner as the Society may think fit.
- To undertake and execute any Trust which may lawfully be undertaken by the Society and may be conducive to its objects.
- To do or concur in doing all such other things as may be considered conducive or incidental to the attainment of the aforesaid objects or to the business interests of newspapers and periodicals in general or of the Society or any of its members in particular.

## NOTES

### **AINEC (All India Newspaper Editor's Conference)**

It is most famous for its code of ethics established in 1968. The Code of Ethics for the Press in Reporting and Commenting on Communal Incidents adopted in 1968 is as follows:

1. A free press can flourish only in a free society. Communalism is a threat to the fabric of our free society and to the nation's solidarity.
2. The press has a vital role to play in the consummation of the fundamental objectives enshrined in our Constitution, namely, democracy, secularism, national unity, and integrity and the rule of law. It is the duty of the press to help promote unity and cohesion in the hearts and minds of the people, and refrain from publishing material tending to excite communal passions or inflame communal hatred.
3. To this end the press should adhere to the following guidelines in reporting on communal incidents in the country:
  - (a) All editorial comments and other expressions of opinion, whether through articles, letters to the Editor, or in any other form should be restrained and free from scurrilous attacks against leaders or communities, and there should be no incitement to violence.
  - (b) Generalised allegations casting doubts and aspersions on the Patriotism and loyalty of any community should be eschewed.
  - (c) Likewise, generalised charges and allegations against any community of unfair discrimination, amounting to inciting communal hatred and distrust, must also be eschewed.
  - (d) Whereas truth should not be suppressed, a deliberate slanting of news of communal incidents should be avoided.

## NOTES

- (e) News of incidents involving loss of life, lawlessness, arson, etc. should be described, reported, and headlined with restraint in strictly objective terms and should not be heavily displayed.
- (f) Items of news calculated to make for peace and harmony and help in the restoration and maintenance of law and order should be given prominence and precedence over other news.
- (g) The greatest caution should be exercised in the selection and publication of pictures, cartoons, poems, etc. so as to avoid arousing communal passions or hatred.
- (h) Names of communities should not be mentioned nor the terms “majority” and “minority” communities be ordinarily used in the course of reports.
- (i) The source from which casualty figures are obtained should always be indicated.
- (j) No facts or figures should be published without fullest possible verification. However, if the publication of the facts or figures is likely to have the effect of arousing communal passions, those facts and figures may not be given.

### **IFWJ**

The largest journalist organization in the non-aligned world is the Indian Federation of Working Journalists, founded in New Delhi on 28 October 1950.

Independent India’s first trade union of media persons, the IFWJ has now over 30,000 primary and associate members, working for electronic media, news agencies and 1,260 journals of 17 languages in 35 states and Union Territories. Overseas Indians, employed in other continents, are among its primary members. The IFWJ’s fraternal organisations in the media world are the National Federation of Newspaper Employees (N.F.N.E., Kolkata) and the National Confederation of Newspaper and News Agencies’ Employees Organizations (Mumbai).

As the only professional body of working journalists, having its branches in every city, town and publication centre of India, the IFWJ’s regional and territorial units have set up press clubs, press academies, reference libraries, training institutes and study circles. They publish professional journals and engage in activities like media researches, trade union struggles, human right campaigns, environmental protection and anti-war movements. The IFWJ’s state units all over India own immovable property in different cities worth Rs. 15 crores (\$ 4.5 millions).

### **AAAI**

Advertising Agencies Association of India (AAAI) is the official, national organisation of advertising agencies, formed in 1945, to promote their interests. The Association promotes professionalism, through its founding principles, which uphold sound business practices between Advertisers and Advertising Agencies

and the various media. AAAI today is truly representative, with a very large number of small, medium and large-sized agencies as its members, who together account for almost 80% of the advertising business placed in the country. It is thus recognised as the apex body of and the spokesperson for the Advertising industry at all forums – Advertisers and Media owners and their associations and Government.

### **ILNA**

**The Indian Languages Newspapers Association (ILNA)** was formed on June 14, 1941. Indian Languages Newspapers Association continues to serve language publishers from capital towns, small towns and even very small district towns and thus reaches to publishers in nooks and corners of the country. ILNA believes that the language publications can play a far greater role in defending democracy in the country and to rid it of corruption, nepotism and lawlessness. Concerned that the governments are now patronising English media under the false notion that the decision makers know only English and language newspapers are not read by those influence, ILNA is determined to remove this myth. It is solely devoted to serve and protect interests of language publications. It has over 700 members from all major states of the country. ILNA is trying to become a professional body that safeguards the interests of publishers as well as guides them to improve their publications by better management and information.

### **NOTES**

---

## **12.4 MEDIA EDUCATIONAL INSTITUTIONS**

---

There are several mass media institutions in India which promote education and research in the area of journalism and mass communication. Let us look at two of the mass media institutions in India in this section:

### **IIMC**

The Indian Institute of Mass Communication (IIMC), was registered under the Societies Registration Act, 1860 (XXI of 1860), on 17th August, 1965 with the objective of teaching, training and undertaking research in the areas of journalism, media and mass communication. IIMC has graduated to conducting specialized courses for meeting diverse and demanding requirements of the rapidly expanding and changing media industry in modern times.

As of today, apart from training officers of the Indian Information Service, the Institute conducts a number of Post-Graduate Diploma Courses in Print Journalism (English, Hindi, Urdu, Odia, Marathi and Malayalam), Radio & T.V. Journalism and Advertising & Public Relations. The Institute also conducts a Postgraduate Diploma Course in Development Journalism for middle-level working journalists from Asian, African, Latin American and East European countries, sponsored by the Ministry of External Affairs, Government of India since 1969, under the ITEC, SCAAP and TCS of Colombo Plan Schemes. A number of specialized short-term Courses, ranging from one to four weeks, are also organized

## NOTES

to meet the ever-growing training needs of communication professionals working in various media, publicity and operational outfits of the Central and State Governments, as well as in Public Sector Organizations.

The Institute also collaborates with different National and International agencies in conducting training, seminars, workshops etc. and in undertaking joint research projects. In recent times, mass communication has undergone a paradigm shift and has emerged as a major area of activity impacting the process of decision-making. It has rapidly acquired importance and prominence and has become a major attraction for students pursuing different academic disciplines. The Information Technology revolution sweeping the globe has significantly contributed to the expansion and changing contours of the mass media. In the changing environment, IIMC continuously evaluates and revises its course curricula to effectively meet contemporary challenges thrown up, enabling the effectiveness of the Courses in the changed scenario. Through its continuous hard work over the half century and as a result of its excellent delivery mechanisms, IIMC has consistently retained the envious reputation of a “Centre of Excellence” in the arena of communication teaching, training and research and has consistently maintained rank among the top media institutes of the country in various surveys.

### **Film and Television Institute of India (FTII)**

The Film Institute of India was set-up by the Government of India in 1960 under the Ministry of Information & Broadcasting. Following the addition of Television Wing in 1974, the Institute was re-designated as Film and Television Institute of India (FTII). The institute was registered as a Society in October, 1974 under the Registration of Societies’ Act, 1860. The FTII Society consists of eminent personalities connected with Film, Television, Communication, Culture, Alumni of the Institute and Ex-Officio Government Members. The Institute is governed by a Governing Council, headed by Chairman.

The academic policies of the institute are formulated by the Academic Council and the matters involving finance are controlled by the Standing Finance Committee. The Institute consists of two Wings - the Film and Television Wing. Film Wing offers three year post graduate diploma courses in Direction, Cinematography, Sound Recording & Sound Design, Editing and Art Direction and Production Design, two year post graduate diploma course in Acting & one year post graduate certificate course in Feature Film Screenplay Writing. The Television Courses consist of one year post graduate certificate course in Television with specializations in Direction, Electronic Cinematography, Video Editing, Sound Recording & TV Engineering. FTII also provides in service training to the officers of all grades of Doordarshan. Short-Term courses are also conducted in specialized areas for the Doordarshan staff, IIS probationers etc. FTII, in collaboration with NFAI, Pune, also organizes intensive Film Appreciation Course, every year.



## **Satyajit Ray Film and Television Institute (SRFTI)**

Satyajit Ray Film and Television Institute (SRFTI) was established in 1995 as an autonomous academic institution and is registered under the West Bengal Societies Registration Act, 1961. Named after the legendary film maestro Satyajit Ray, the Institute offers 3-year post-graduate diploma courses in Six specializations – (1) Direction & Screenplay Writing (2) Cinematography (3) Editing (4) Sound Recording & Design, (5) Producing for Film & Television and (6) Animation Cinema. Total 72 students have enrolled in SRFTI during FY 2017-18 for the above three year post graduate diploma courses. Further, currently there are 12 international students studying in SRFTI.

SRFTI has also started 2 years post graduate diploma course on Electronics & Digital Media (E&DM) from 14th August 2017. Total number of students in the 1st batch is 30. Details of the courses are (1) Writing for electronic & digital media (2) Electronic & digital media management (3) Videography for electronic & digital media (4) Producing for electronic & digital media (5) Editing for electronic & digital media (6) Sound for electronic & digital media.

Apart from the government related media educational institutions, there are also several private media educational institutions like:

- Asian College of Journalism, Chennai
- A.J.K. Mass Communication Research Centre (AJK MCRC), Delhi
- MICA, Ahmedabad
- Symbiosis Institute of Media and Communication, Pune
- Xavier Institute of Communication, Mumbai

### **Check Your Progress**

3. What is the AAI?
4. When was the Film Institute of India set up?
5. Where are the academic policies of the institute formulated?

## **12.5 ANSWERS TO CHECK YOUR PROGRESS QUESTIONS**

1. PTI was registered in 1947 and started functioning in 1949.
2. IANS is divided into six business verticals: IANS News Service (English & Hindi), IANS Multimedia, IANS Publishing, IANS Media Consultancy, IANS Software Services, IANS Mobile Services.

## **NOTES**

## NOTES

3. Advertising Agencies Association of India or AAAI is the official, national organisation of advertising agencies, formed in 1945, to promote their interests.
4. The Film Institute of India was set-up by the Government of India in 1960 under the Ministry of Information & Broadcasting.
5. The academic policies of the institute are formulated by the Academic Council and the matters involving finance are controlled by the Standing Finance Committee.

---

## 12.6 SUMMARY

---

- News agencies refer to organizations who are involved in the process of gathering, writing and distributing news to different newspapers, radio, government agencies, periodicals, or other such audience. They are also known by the name of wire service, press association, press agencies, or news service.
- Press Trust of India (PTI) is India's premier news agency, having a reach as vast as the Indian Railways.
- PTI is run by a Board of Directors with the Chairmanship going by rotation at the Annual General Meeting.
- IANS (Indo-Asian News Service) provides news and analyses from India and South Asia from the region's perspective.
- IANS was established in 1986, initially to serve as an information bridge between India and its thriving Diaspora in North America.
- Founded over 50 years ago, ANI (Asian News International) is today South Asia's leading multimedia news agency with over 100 bureaus in India, South Asia and across the globe.
- The early beginnings of the Indian Newspaper Society can be traced back to October 11, 1927, when a Society bearing the name, The India, Burma & Ceylon Newspapers' London Committee came into being, the name of which was changed to Indian & Eastern Newspaper Society (IENS) on October 4, 1935.
- The All India Newspaper Editor's Conference is most famous for its code of ethics established in 1968.
- The largest journalist organization in the non-aligned world is the Indian Federation of Working Journalists, founded in New Delhi on 28 October 1950.
- Independent India's first trade union of media persons, the IFWJ has now over 30,000 primary and associate members, working for electronic media, news agencies and 1,260 journals of 17 languages in 35 states and Union Territories.

- The Indian Languages Newspapers Association or ILNA was formed on June 14, 1941. Indian Languages Newspapers Association continues to serve language publishers from capital towns, small towns and even very small district towns and thus reaches to publishers in nooks and corners of the country.
- The Indian Institute of Mass Communication (IIMC), was registered under the Societies Registration Act, 1860 (XXI of 1860), on 17th August, 1965 with the objective of teaching, training and undertaking research in the areas of journalism, media and mass communication.
- The Film Institute of India was set-up by the Government of India in 1960 under the Ministry of Information & Broadcasting. Following the addition of Television Wing in 1974, the Institute was re-designated as Film and Television Institute of India (FTII).

## NOTES

---

### 12.7 KEY WORDS

---

- **Cinematography:** It means the science or art of motion-picture photography by recording light or other electromagnetic radiation, either electronically by means of an image sensor, or chemically by means of a light-sensitive material such as film stock.
- **Sound Design:** It is the art and practice of creating sound tracks for a variety of needs. It involves specifying, acquiring or creating auditory elements using audio production techniques and tools.
- **Public Relations:** It is the professional maintenance of a favourable public image by a company or other organization or a famous person.

---

### 12.8 SELF ASSESSMENT QUESTIONS AND EXERCISES

---

#### Short-Answer Questions

1. Write a short-note on the Press Trust of India.
2. Why was IANS established?
3. What is the largest journalistic organization in India?

#### Long-Answer Questions

1. What is the Indian Newspaper Society? Describe its objectives.
2. Describe the code of ethics established at the All India Newspaper Editor's Conference.
3. Describe some of the major media educational institutions in the country.

**NOTES**

---

## **12.9 FURTHER READINGS**

---

- Holmes, David. 2005. *Communication Theory: Media, Technology and Society*. London: Sage Publishers.
- Hartley, John. 2002. *Communication, Culture and Media Studies: The key Concepts*. New York: Routledge.
- Rosengren, Karl Eric. 2000. *Communication: An Introduction*. London: Sage Publishers.
- Fiske, John. 1982. *Introduction to Communications Studies*. London: Methuen & Co.
- Asa Berger, Arthur. 1995. *Essentials of Mass Communication Theory*. Thousand Oaks, CA: Sage Publications.
- Mcquail, Denis. 1983. *Mass Communication Theory*. London: Sage Publication.
- Schramm, Wilbur. 1966. *The Story of Human Communication*. New York: Harper and Row Publishers.
- William, Raymond. 1976. *Communications*. London: Penguin Books.

---

## UNIT 13 INTRODUCTION TO MASS MEDIA

---

### NOTES

#### Structure

- 13.0 Introduction
- 13.1 Objectives
- 13.2 Meaning and Concept of Mass Media
- 13.3 The Influence of Technology on the Means of Communication
- 13.4 Answers to Check Your Progress Questions
- 13.5 Summary
- 13.6 Key Words
- 13.7 Self Assessment Questions and Exercises
- 13.8 Further Readings

---

### 13.0 INTRODUCTION

---

In the previous unit, you learnt about various Indian news agencies, as well as the different media educational institutions. This unit will discuss the meaning and concept of mass media. It will also discuss the influence of technology on mass communication. Mass media plays an important role in today's world as it helps to bridge the gap between different nations and helps significantly in their development too. One can trace its importance from earlier centuries too, when the development of printing press helped the nation as well as its people. However, in present day scenario, mass media helps the nation but has emerged more significant for the society as well. Mass communication has emerged as a very lucrative career option for people as it has lot of growth opportunities in various fields such as advertising, radio jockeys, and journalism and so on.

---

### 13.1 OBJECTIVES

---

After going through this unit, you will be able to:

- Discuss the meaning and concept of mass media
- Describe how technology influences the means of communication

---

### 13.2 MEANING AND CONCEPT OF MASS MEDIA

---

Mass media can be defined as a means of communication with the masses at large. These may include print, radio, television and digital media. The mass media can also be defined in terms of an organization where one or more types of technologies are used for communicating with a large number of people and is also referred to as mass communication.

## NOTES

Mass media's history can be traced back from the periods between 1860 and 1930, in this era various innovations were made in the fields of electronics and chemical industries, and is known as a formative era for the field of mass media. During this phase, several developments were made in various fields such as photography, cinematography, wireless telegraphy, phonography and radio, and all of these were considered as a means of popular culture of the period. These means also typified the new more intensive capitalization of the leisure industries and their associated concern to address mass audiences.

In 1956, C. Wright Mills, an American sociologist, in his book *The Power Elite* defines mass media as having two key sociological characteristics which are as follows:

- Very few people could communicate with a very large number of people
- Audiences have no effective way to answer back to the communicator

Thus, mass communication is considered as a one-way process. Media organizations from all over the world are bureaucratic and corporate in nature, except in those countries where mass media are under the control of the state. It is also a well-known fact that media output is regulated by governments everywhere, but, these restrictions or curbs may vary in degree and also has comprehensive forms of restrictions in dictatorial types.

The different forms of media that exist today dominates the lives of the people and as a result, the study of mass media is of great interest to sociologists. The main focus of study from the early period of 1930s was to understand the role of power in these emerging technologies, especially radio and television, and in the present scenario, Internet has taken that place. One can observe the power which these technologies hold from the days of Adolph Hitler as well, where his use of radio for propaganda gave an object lesson that electronic media can create an Orwellian situation of mind control, with passive masses dominated by a tiny elite of communicators.

### **Characteristics of Mass Communication**

John Thompson, a sociologist from Cambridge University, UK, was the first to identify five key characteristics of mass communication. They are as follows:

- Thompson suggests that mass communication includes technical and institutional methods of production and distribution. This fact is evident throughout the history of mass media, right from print to Internet, where each can be used for fulfilling the purpose of commercial utility.
- It comprises the commodification of symbolic forms. This meant that the ability to manufacture and sell large quantities of the work is driven by the production of materials. For example, radio stations rely heavily on their

air-time sold to advertisers and newspapers that rely heavily on the space sold to advertisers.

- It helps to separate the contexts of the production and reception of information.
- The reach of mass communication is especially helpful for those who are far removed in time and space is not the same in comparison to the producers of communication.
- Mass communication is a kind of information distribution that is only a one way or one to many type of communication.

## NOTES

### Types of Media and Distinction between its Various Types

We will now discuss the distinction between the various types of media.

- **Mass vs mainstream and alternative media:** The terms mass media and mainstream media are not synonymous but are often used interchangeably. However, one must keep in mind that mainstream media is distinct from alternative media in terms of their content and views expressed. On the other hand, alternative media is a type of mass media which is different as they use technology which is capable of reaching a bigger audience, even though here the target audience is smaller than the mainstream.

In common parlance, mass signifies not a given number of individual recipients of products rather the products which are available in principle to a significantly larger audience.

- **Mass vs local and speciality:** The distinction between mass media and local media can be observed in their different kinds of approaches to the audience. Mass media aims to reach a much larger market and may cover the population of an entire nation, whereas, local media has a very focussed reach as the broadcast is only to a small population and area. The message which is broadcasted thus, focusses on issues related to the region concerned and not the whole world.

The third type of media is called the speciality media, which aims to provide the audience specific demographic content, for example, TV channels which air information related to sports, music and movies.

#### Check Your Progress

1. What do you understand by the term speciality media?
2. Name the sociologist who identified the key characteristics of mass communication.

---

### 13.3 THE INFLUENCE OF TECHNOLOGY ON THE MEANS OF COMMUNICATION

---

#### NOTES

Human communication has travelled through various stages of development. Even though communication was inherent to mankind, the organization of the verbal language eventually developed into non-verbal or written communication. This type of written or non-verbal communication was developed from symbol-based drawings and eventually proceeded to phonemic symbols. A noteworthy, revolutionary stride in the advancement of written communication was the printing press, which led to the proliferation of composed thought and the propagation of illustrations, drawings and photographs. However, this form of communication was basically one-way and not in real time. With the advent of telegraphy, the first real-time remote communication took place. It made immediate transmission of written characters to a distant receiver possible. Telegraphy made use of a coded interpretation, like Morse code, of text and numerics into an on/off digitized representation. This could be decoded by a human specialist at the other end, who listened to the clicks of a remote solenoid. Afterwards, telegraphy advanced to a nonstop-length code which was encoded and decoded mechanically. This coded representation came to be the foundation for storing, recovering and transmitting content by PCs. Telegraphy also became the most important form of one-way communication. It can be called the first generation of communication.

Another invention, which also changed interpersonal communication, was the **telephone**. The biggest advantage was of course the instant reply. It was possible to talk directly to the person at the other end. The second advantage was that while it was possible to recognize the voice of the person at the other end, it was also possible to gauge the tone, urgency and emotion, which is extremely important in interpersonal communication.

Then came the **wireless**, which revolutionized communication. The wireless resulted in immediate and easy transmission of voice to others throughout the globe. Transmission was possible over air and water. Then came **video communication** with the invention of the television which was capable of transmitting not just still but also moving graphics in real time. It was possible to broadcast movie and sound content, even though one-way only.

Development of technology allowed unique requisitions for new applications for video-based communication, which were not only in uni-directional mode, but had one-to-many mode. However, the next phase was digital and allowed transfer of voice, data and fax, along with several other value-added services. Now, these second generation systems are still evolving with ever-increasing data rates through new technologies like HSCSD (High-Speed Circuit Switched Data) and GPRS (General Packet Radio Service). At the same time, more and more customers are interested in conveying information, telephony utilities, worldwide roaming services, messaging, movie and Web access on one single gadget. This has brought about worldwide standards accessible like Wireless Application Protocol (WAP). By



applying fast information transfer and radio terminal innovation (like Bluetooth), third generation systems are being developed to furnish the transmission capacity required for various uses. 3G empowers multimedia and is currently in the process of being standardized under 3rd Generation Partnership Project of 3GPP (a standardization body with representatives from Asia, Europe and America, which is helping to establish technical specifications).

Even if there are many differences, for the first time, an amalgamation of different types of media is taking shape. If this is truly executed, the existing huge knowledge base will be provided to people all across the globe. It can also change the way we look at audio and video communication today.

Information and commerce will flow freely with data sharing, adequate security and safeguards. The world will become a global village in the true sense of the word. There would also be quick communication based on multimedia, which would result in the following:

- Expansion in productivity
- Better quality of life
- Development in education
- Development in entertainment
- Improved cross-cultural understanding

#### Check Your Progress

3. How did written communication develop?
4. What would quick communication based on multimedia result in?

### 13.4 ANSWERS TO CHECK YOUR PROGRESS QUESTIONS

1. The term speciality media aims to provide the audience specific demographic content, for example, TV channels which air information related to sports, music and movies.
2. John Thompson, a sociologist from Cambridge University, UK, was the first to identify five key characteristics of mass communication.
3. Written communication was developed from symbol-based drawings and eventually proceeded to phonemic symbols.
4. Quick communication based on multimedia would result in the following:
  - Expansion in productivity
  - Better quality of life
  - Development in education

#### NOTES

## NOTES

---

### 13.5 SUMMARY

---

- Mass media can be defined as a means of communication with the masses at large. These may include print, radio, television and digital media.
- Mass media's history can be traced back from the periods between 1860 and 1930, in this era various innovations were made in the fields of electronics and chemical industries, and is known as a formative era for the field of mass media.
- The different forms of media that exist today dominates the lives of the people and as a result, the study of mass media is of great interest to sociologists.
- Mass communication includes technical and institutional methods of production and distribution. This fact is evident throughout the history of mass media, right from print to Internet, where each can be used for fulfilling the purpose of commercial utility.
- The terms mass media and mainstream media are not synonymous but are often used interchangeably. However, one must keep in mind that mainstream media is distinct from alternative media in terms of their content and views expressed.
- Human communication has travelled through various stages of development. Even though communication was inherent to mankind, the organization of the verbal language eventually developed into non-verbal or written communication.
- An invention that changed interpersonal communication, was the telephone. The biggest advantage was of course the instant reply. It was possible to talk directly to the person at the other end.
- Development of technology allowed unique requisitions for new applications for video-based communication, which were not only in uni-directional mode, but had one-to-many mode.
- Even if there are many differences, for the first time, an amalgamation of different types of media is taking shape. If this is truly executed, the existing huge knowledge base will be provided to people all across the globe.

---

### 13.6 KEY WORDS

---

- **Phonemic Symbols:** They are a set of symbols or codes used to show what a speech sound or letter sounds like.
- **Non-verbal Communication:** It is communication through sending and receiving wordless cues. It includes the use of visual cues such as body

language, distance and physical environments/appearance, of voice and of touch.

- **Multimedia:** It is a broad field of study with a variety of specific focuses such as broadcast journalism and filmmaking.

## NOTES

---

### 13.7 SELF ASSESSMENT QUESTIONS AND EXERCISES

---

#### Short-Answer Questions

1. Define mass media.
2. List the characteristics of mass communication.

#### Long-Answer Questions

1. What are the different types of media? Distinguish between its various types.
2. Describe the influence that technology has had on the means of communication throughout history.

---

### 13.8 FURTHER READINGS

---

Baran, Stanley J and Dennis K. D Avis. 2009. *Mass Communication Theory: Foundations, Ferment, and Future*, 6th Edition. California, US: Wadsworth.

Kumar, Keval J. 2010. *Mass Communication in India*. Mumbai: Jaico Publications.

Jackson, John D., Greg Marc Nielsen, Yon Hsu. 2011. *Mediated Society: A Critical Sociology of Media*. USA: Oxford University Press.

Smith, Joel. 1995. *Understanding the Media: A Sociology of Mass Communication*. Cresskill, New Jersey: Hampton Press.

**NOTES**

---

## **UNIT 14 A DISCUSSION ON THE CHARACTERISTICS OF INDIVIDUAL MASS MEDIUM**

---

### **Structure**

- 14.0 Introduction
- 14.1 Objectives
- 14.2 Mass Media in India
  - 14.2.1 Present Status of Mass Media
  - 14.2.2 Advantages and Limitations of Mass Media
- 14.3 Answers to Check Your Progress Questions
- 14.4 Summary
- 14.5 Key Words
- 14.6 Self Assessment Questions and Exercises
- 14.7 Further Readings

---

### **14.0 INTRODUCTION**

---

In the previous unit, you were introduced to the concept of mass media. This unit will discuss the role of mass media in Indian society.

India is a multi-cultural, multi-linguistic and multi-ethnic society. This multi-tier social set-up is vibrant and complex. The social and cultural layers of this nation have strong indigenous traditions. However, the society is also reflective of cultural and social evolution. Mass media including television, newspapers, radio, film and Internet have been an integral part of this evolution. In a society like India with so much diversity and differences, mass media have played a significant role in every phase of development. Mass media facilitate dissemination of information and communication to a vast number of people. There is a strong heterogeneity of media audiences. And more often than not, the media content caters to different groups rather than to a homogenous set of audience.

Media performs four basic functions for society: surveying the environment to provide information; correlating response to this information (editorial function); entertaining the media user (diversion function); and transmitting the country's cultural heritage to future generations (socialization or educational function). In a developing country, mass media is also expected to play an additional role – to mobilize public support for national development. Media also performs a role in subtly shaping perceptions and moulding public opinion by means of this symbolism. The use of media effectively helps citizens to engage meaningfully with the media in an active and a critical manner.

---

## 14.1 OBJECTIVES

---

After going through this unit, you will be able to:

- Discuss the influence of mass media in India
- Describe the present status of mass media
- Explain the advantages and limitations of mass media

## NOTES

---

## 14.2 MASS MEDIA IN INDIA

---

India is a multi-cultural and multi-religious society. It has been regarded as the 'oldest living civilization' in the world by some historians. Different regional, social, linguistic and economic groups live in this multifaceted and diverse Indian society. India is one of the ancient nations which has survived, preserved and propagated its culture to the rest of the world.

Despite the diversity in cultures and traditions that prevails throughout India, there is an underlying similarity in the social structure. This contributes to a unity within this diversity.

Here is a brief explanation of the existing Indian social structure:

1. **Caste system:** The caste system forms the basic foundation of Indian society. According to this system, there are four major castes - the Brahmins, the Kshatriyas, the Vaishyas and the Sudras. The caste system started off as a division of labour. The Brahmins were the priests and teachers. In terms of hierarchy, Brahmins were considered the first caste. The Kshatriyas were the warriors, rulers and soldiers. Vaishyas included merchants and traders while the Sudras were responsible for all the menial labour in society. While it started off being merely an occupational division, the caste system assumed a hereditary nature resulting in discrimination and ill-treatment in the name of the lower castes. Untouchability is still practised in the Indian society, though the constitution does not permit it and has deemed it as a punishable offence. However, with growing literacy and economic progress such as urbanization there is an evident decline in the practice of the caste system.
2. **Family:** The family holds great importance in the Indian social structure. Joint families are a popular phenomenon in the Indian society. However with greater urbanization, and youth leaving home for better educational and employment opportunities, there is a growing trend towards nuclear family settings, especially in the cities.
3. **Women:** History shows that there have been many significant women figures in the social and political context of the country. However, there are several instances of atrocities against women including domestic

## NOTES

violence and sexual abuse as by and large India has had a patriarchal set-up. The country also has an imbalanced sex ratio with relatively fewer girls as compared to boys. With an overtly male dominated structure, some parts of the country are infamous for female foeticide, infanticide and for denying the right to education to girls.

4. **Men:** Indian society is pre-dominantly patriarchal in nature. There is a strong desire prevalent in most families to have a male heir to carry forward the name of the family. Men are also officially designated as bread earners. However, there is an evolving trend towards women's active participation in the matters of the house and their financial independence because of progress and participation on the professional front.

This multi-tier Indian social set-up is both vibrant and complex. The social and cultural layers of this nation have strong indigenous traditions. However, the society is also reflective of cultural and social evolution. Mass media have been an integral part of this evolution.

### **Mass Media Influence**

A historic insight into the development of various mass media in India will throw light on how media in each era has been a strong social and cultural force in that period. The advent of independence in August 1947 removed the shackles of the colonial era and a new horizon arose in all aspects of the country's life. The mass media also stepped up to the occasion. There was tremendous progress in the fields of print and electronic media including cinema and television; the rate of literacy improved, and there was a far greater interaction between the public through the media.

In 1976, twenty-nine years after independence, India had 13,320 newspapers in 65 languages. The largest number of newspapers was in Hindi – a language spoken by 40% of the country's population. The total number of weeklies and other journals in all Indian languages, numbered 12,445. This number has since then increased. Today the number of print publications in India is close to 40,000 according to the 2008-09 figures from the Registrar of Newspapers for India.

Starting with only six broadcasting stations in 1947, All India Radio (AIR) has also greatly extended its services. In 1977, there were 155 AIR radio stations that included relay stations. Today the number is close to 400. With the privatization of air waves, private FM radio has made strong inroads and impact in India.

Television arrived in India in 1959 on a rather restricted scale. The UNESCO along with support from USA, West Germany (at that time), Yugoslavia and Japan helped in establishing and extending the television network in India. Today India is ranked second in the world in terms of cable networks and the 24x7 nature of television programming across different genres and formats is a current spellbinding phenomenon.

Mass communication channels have a bigger and more complex role to perform in a diverse society like India. In fact, current Indian society is increasingly saturated by the mass media. For most of us, print, film, music, and television are central parts of our daily lives. The growth of new technologies including the web, mobile phones, and various digital platforms has altered our understanding of the mass media. These developments are not only changing the media landscape structurally and functionally, but their reach and influence is much wider and deeper in the socio-cultural context.

Mass media wield a powerful influence on the world around. This is true in these days of 24x7 media. From the daily newspaper dropped at your door in the morning, other forms of printed text, watching television, time spent on the web for work, surfing or social networking, there is a constant scenario of engaging and interacting with and via media.

Mass media facilitate dissemination of information and communication to a vast number of people. According to Wilbur Schramm, “A mass medium is essentially a working group organized around some device for circulating the same message, at about the same time, to large numbers.” The mass media include everything from press, radio, cinema, television, books, magazines, pamphlets, mail literature to the World Wide Web. The reach extends to a vast heterogeneous population across the world.

The range, diversity and reach of the media make them strong and influential. The media’s influence can happen in many different ways. There can be several types of media effects – social, cultural, economic and political. Social scientists have studied the concept of media effects in detail. The study of effects of media is a debatable and controversial concept. The early theorists labelled the mass media as a set of cancerous forces that would corrupt the society and thus emphasized the regulation of media. There were however other scholars who criticized this dominant paradigm of media influence and offered a more moderate perspective.

#### **14.2.1 Present Status of Mass Media**

As per FICCI’s March 2018 report on Re-imagining India’s M&E,

- The Indian M&E sector reached INR1.5 trillion (USD 22.7 billion) in 2017, a growth of almost 13 percent over 2016. With its current trajectory, we expect it to cross INR2 trillion (USD 31 billion) by 2020, at a CAGR of 11.6 per cent.
- The TV industry grew from INR594 billion to INR 660 billion in 2017, a growth of 11.2% (9.8% net of taxes). Advertising grew to INR267 billion while distribution grew to INR393 billion. Advertising comprised 40% of revenues, while distribution was 60% of total revenues. At a broadcaster level, however, subscription revenues (including international subscription) made up approximately 28% of revenues.

#### **NOTES**

## NOTES

- The fall in broadband prices could pose a threat to the cable and DTH industry. It could lead to increased viewership of TV content on larger screens, for more affluent customers, second television connections and nuclear families, who can move to OTT platforms for their TV consumption. EY estimates that by 2020, there would be around 4 million people who primarily depend on OTT platforms for their content. A number of distribution companies are investing in broadband to mitigate this risk, leading to increased ARPUs and margins.
- Print accounted for the second largest share of the Indian M&E sector, growing at 3% to reach INR303 billion in 2017. Print media is estimated to grow at an overall CAGR of approximately 7% till 2020 with vernacular at 8%-9% and English slightly slower. This growth is expected despite the FDI limit remaining unchanged at 26% and therefore restricting access to foreign print players and the imposition of GST at 5% on the advertising revenues of the print industry for the first time in history
- Print companies are focusing on enhancing their digital footprint. Almost all the large print companies have established their news websites and/or apps. While most Indian publishers have created an online presence, digital content monetization is still significantly under-penetrated for many players. At an industry level, less than 5% of print companies' total revenues are driven from digital. Traditional newspapers faced competition from domestic digital-born startups such as Scroll, Quartz India and The Quint, also aggregators such as Inshorts, Firstpost and DailyHunt, as well as, perhaps more importantly, from large international non-news players such as Yahoo, Google and Facebook because of their large user base.
- The advent of large OTT platforms in India such as Google, Netflix, Amazon, Eros Now, Jio Cinema, etc, apart from OTT offerings of various telecom companies, has significantly increased the demand for films' digital rights. The sudden surge in demand, especially the demand for exclusive rights, has resulted in a significant increase in the value of digital rights, which as per industry estimates have increased multi-fold (depending on the length of the deal and type of rights acquired) over the last two to three years. Digital revenue generated INR 8.5billion for the film segment in 2017 an increase of 40% over 2016.
- There is increasing focus on Virtual Reality (VR), Augmented Reality (AR) & Mixed Reality (MR) as technologies being increasingly used in everyday content and communication. Of these, VR is looked upon as the next platform for film viewing globally (the word Film being used here to mean narrative audio-visual storytelling).
- India has already become the second largest market for social networking giants such as Facebook (with over 200 million users) and LinkedIn (with over 42 million users) and is expected to surpass the US to lead the global



tally of the largest Facebook user base on mobile devices in the next couple of years. In addition, Instagram has 30 million users<sup>36</sup> and Snapchat has reached 10% penetration. Many social media platforms have begun to stream short videos, and we expect the trend to increase in the near future. Research by Omidyar Network suggests that Indians spend 200 minutes a day on mobile apps, 40% of which is spent on social media apps.

- The Indian radio segment increased by around 6.5% in 2017, on the back of the lingering effect of demonetization between November 2016 to March 2017 and the impact of GST. Gross of taxes (INR billion) Key drivers of growth for the radio segment remain a large youth population, growth in the quality and quantity of film music on the radio, built-in FM receivers in most hand phones sold in India (76% of audiences listen to FM radio via mobile devices), increased time spent out of the home in transit, building a strong local connect. Also, radio is a free medium, and free offerings will always find a place in the entertainment mix of most Indians.

## NOTES

### 14.2.2 Advantages and Limitations of Mass Media

Let us first discuss the advantages of mass media.

#### Advantages

1. Mass media helps educate people. Through television and radio programs, individuals get to learn about health matters, environmental conservation, and much more.
2. Through mass media, people are able to receive the latest news in a very short time. Distance is not a barrier for news. People get news daily through the media and this keeps them updated on global events.
3. People get to bring out their hidden talents through mass media. Through media, individuals can showcase their talents such as comedy, acting and singing.
4. Media also helps increase the knowledge of children. They can learn from quiz programs, animal programs and so on.
5. Radio is a convenient mass media tool through which people receive a synopsis of the news. News can also be accessed through hand held devices like mobile phones.
6. Mass media is a great way to promote mass consumer products. This can in turn increase sales of the product.
7. It serves as a good source of entertainment. People get entertained through music and television programs.
8. Television allows electronic duplication of information. This reduces the production cost making mass education possible.

## NOTES

9. Media leads to diffusion of different cultures. Media showcases different cultural practices.
10. It helps people around the world to understand each other and embrace their differences.

### Limitations

1. One major limitation is that mass media leads to individualism. People spend too much time on the Internet and watching television. As a result, socialization with friends, family and neighbours is affected.
2. Some media contents are not suitable for children. Limiting children's access to such content can be difficult.
3. Newspaper is geographically selective.
4. Increase in advertisements in television and radio is making them less attractive.
5. Internet as a form of media opens up possibilities of imposters, fraud and hacking.
6. Media can be addictive, e.g. some television programs and internet. This can lead to decrease in people's productivity.
7. Health problems. Prolonged watching of television can lead to eyesight problems and radio listening using earphones exposes one to possible hearing defects.
8. It glamorize drugs and alcohol. Some programs make the use of these things appear cool'.
9. It can lead to personal injury. Some people decide to follow the stunts that are showcased in the media. This can lead to injuries.
10. Another limitation of mass media is that it can lead to ruin of reputation. It is possible for one to create an anonymous account. Such accounts can be used to for malicious reasons such as spreading rumours. This can lead to ruin of reputation of an individual or a company.

### Check Your Progress

1. What forms the basic foundation of Indian society?
2. What is a mass medium?
3. What is the present focus of print companies in India?

---

### 14.3 ANSWERS TO CHECK YOUR PROGRESS QUESTIONS

---

*A Discussion on the  
Characteristics of Individual  
Mass Medium*

1. The caste system forms the basic foundation of Indian society. According to this system, there are four major castes - the Brahmins, the Kshatriyas, the Vaishyas and the Sudras.
2. A mass medium is essentially a working group organized around some device for circulating the same message, at about the same time, to large numbers.
3. Print companies in India today are focusing on enhancing their digital footprint. Almost all the large print companies have established their news websites and/or apps.

### NOTES

---

### 14.4 SUMMARY

---

- India is a multi-cultural and multi-religious society. It has been regarded as the ‘oldest living civilization’ in the world by some historians.
- Different regional, social, linguistic and economic groups live in this multifaceted and diverse Indian society.
- Despite the diversity in cultures and traditions that prevails throughout India, there is an underlying similarity in the social structure. This contributes to a unity within this diversity.
- The caste system forms the basic foundation of Indian society. According to this system, there are four major castes - the Brahmins, the Kshatriyas, the Vaishyas and the Sudras. The caste system started off as a division of labour.
- The family holds great importance in the Indian social structure. Joint families are a popular phenomenon in the Indian society.
- The advent of independence in August 1947 removed the shackles of the colonial era and a new horizon arose in all aspects of the country’s life. The mass media also stepped up to the occasion.
- Mass communication channels have a bigger and more complex role to perform in a diverse society like India. In fact, current Indian society is increasingly saturated by the mass media.
- The Indian M&E sector reached INR1.5 trillion (USD 22.7 billion) in 2017, a growth of almost 13 percent over 2016.
- Mass media helps educate people. Through television and radio programs, individuals get to learn about health matters, environmental conservation, and much more.

- One major limitation is that mass media leads to individualism. People spend too much time on the Internet and watching television. As a result, socialization with friends, family and neighbours is affected.

## NOTES

---

### 14.5 KEY WORDS

---

- **Caste System:** It is a form of social stratification characterized by endogamy, hereditary transmission of a lifestyle which often includes an occupation, status in a hierarchy, customary social interaction, and exclusion.
- **GST:** It is a value-added tax levied on most goods and services sold for domestic consumption.
- **Startups:** It basically refers to a newly established business.

---

### 14.6 SELF ASSESSMENT QUESTIONS AND EXERCISES

---

#### Short-Answer Questions

1. Briefly discuss the existing Indian social structure.
2. How has mass media influenced Indian society since independence?

#### Long-Answer Questions

1. Discuss the advantages and limitations of mass media.
2. Describe the present status of mass media in India.

---

### 14.7 FURTHER READINGS

---

- Mcquail, Denis. 2013. *Journalism and Society*. New Delhi: Sage Publications.
- Bro, Peter. 2018. *Models of Journalism: The Functions and Influencing Factors*. London: Routledge.
- Burns, Lynette Sheridan. 2002. *Understanding Journalism*. New Delhi: Sage Publications.
- Raghavan, G.N.S. 1994. *Press in India: A New History*. New Delhi: Gyan Publishing House.
- Sharma, K. Suresh. 2006. *Press in India*. New Delhi: Vista International Publishing House.
- Parthasarathy, Rangaswami. 1984. *Basic Journalism*. New Delhi: Macmillan India Limited.
- <http://ficci.in/spdocument/22949/FICCI-study1-frames-2018.pdf>